

# LS600X WORKSHEET

(Use This Worksheet to Generate Custom Configurations)

Select ONE of EACH of the following options: (Factory default shown in bold, consult factory for Other options)

## Float

- Stainless Steel**
- Buna-N
- Polypropylene

## Stem

- Stainless Steel**
- PVC

## Special Features (Optional)

- Adjustable
- Test Lever (S/S Float Only)
- Riser Spacer Mount

## Mounting

- None
- 2" S/S Bushing**
- 1.5" S/S Bushing
- 2" PVC Bushing
- 2" S/S 150# Flange
- 4" S/S 150# Flange
- Other Bushing
- \_\_\_\_\_
- Other Flange
- \_\_\_\_\_

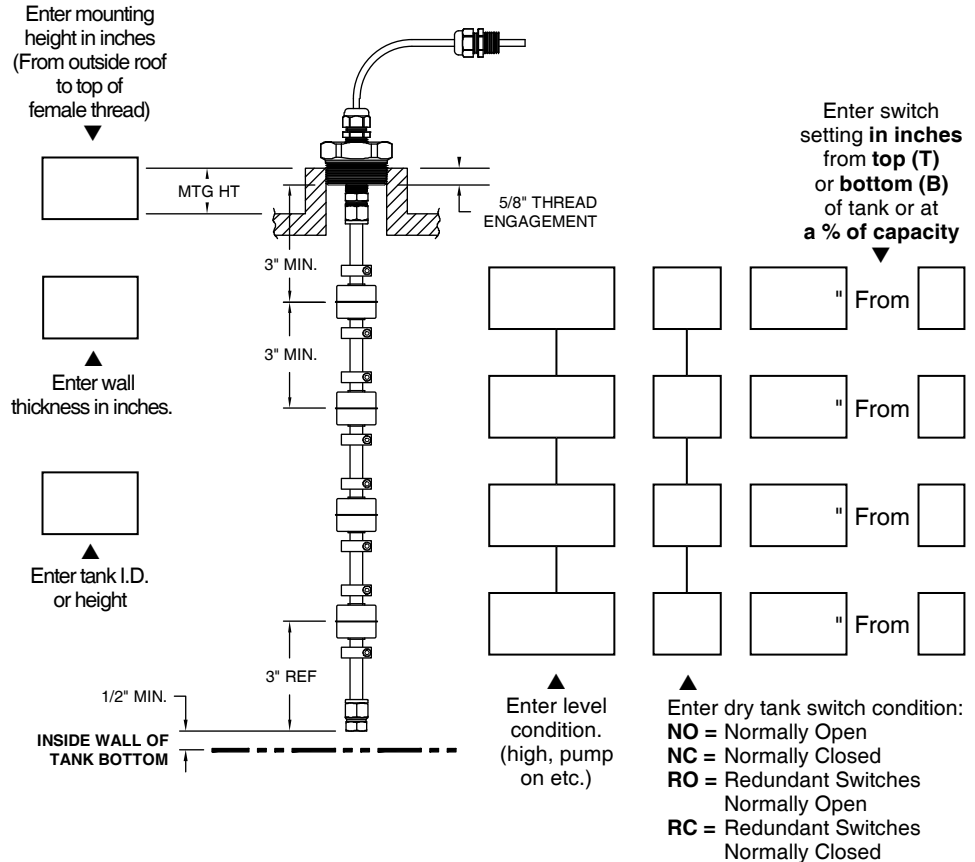

Additional Tank Information: (Required where setting is given as a percent of volume)

Actual Capacity: \_\_\_\_\_

End Type (Horizontal cylinders only) (Flat, Dished, Spherical, etc.): \_\_\_\_\_

Manufacturer: \_\_\_\_\_