

# INSTALLATION MANUAL

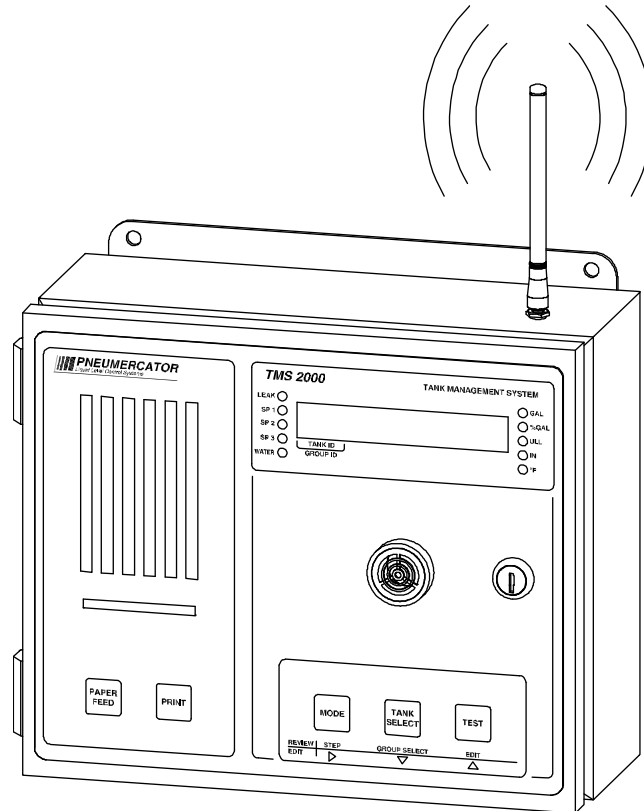

DRAWING NO. 20090 REV. N/C

## **MODEL TMS2000W**

**© COPYRIGHT 2026 PNEUMERCATOR CO., INC.  
1785 EXPRESSWAY DRIVE NORTH  
HAUPPAUGE, NY 11788**

TEL: (631) 293-8450

FAX: (631) 293-8533

<http://www.pneumercator.com>



TABLE OF CONTENTS
-------------------

Section 1	PRODUCT DESCRIPTIONS .....	5
1.1	General System Overview .....	5
1.2	Control Console Description .....	6
1.3	WiDAM (Wireless Data Acquisition Module).....	8
1.3.1	Liquid Level Probe Description .....	10
1.3.2	Liquid Leak Sensor Description .....	11
Section 2	INSTALLATION DETAILS .....	13
2.1	Installation Checklist .....	13
2.2	Control Console Installation .....	14
2.3	WiDAM Installation.....	15
2.4	Level Probe Installation in Underground Tanks.....	17
2.5	Level Probe Installation in Aboveground Tanks .....	19
2.5.1	Riser Pipe Method for Aboveground Tanks.....	20
2.5.2	Bushing or Flange Mount Method for Aboveground Tanks .....	21
	External Leak Sensor Installation .....	23
2.6	Leak Sensor Installation in Steel and Vaulted Tanks .....	23
2.7	Leak Sensor Installation in Piping Sumps and Dispenser Pans.....	24
2.8	Leak Sensor Installation in Fiberglass Tank Annulus.....	25
2.9	Hydrostatic Leak Sensor Installation in Fiberglass Tank Reservoirs.....	26
Section 3	WIRING INSTALLATION AND DIAGRAMS .....	28
3.1	TMS2000W Power Wiring Installation .....	28
3.2	TMS2000W Channel Selection.....	30
3.3	WiDAM Wiring.....	31
3.4	WiDAM Configuration.....	35
3.5	Probe/Sensor Wiring & Splices.....	36
3.6	Programmable Relay Outputs/Contact Closure Inputs.....	40
3.7	Data Communications Wiring .....	41



**SECTION 1 – PRODUCT DESCRIPTIONS**

**1.1 GENERAL SYSTEM OVERVIEW**

The TMS2000W is a fully integrated wireless tank monitoring system that combines inventory management and secondary containment leak detection. Figure 1-1 shows a typical block diagram of how a system should be configured for installation. This diagram is not a detailed wiring diagram, which is found in Section 3 of this manual. Figure 1-1 is to guide the installer in planning the actual installation, and give a general overview of the possible combinations of WIRELESS MODULES, TANKS, LEVEL PROBES, EXTERNAL SENSORS, and OPTIONAL equipment that may be required for a typical installation. Figure 1-1 shows only one (1) WiDAM with one (1) tank and four (4) sensors: however, TMS2000W can monitor up to 12 WiDAMs for a total of up to 12 tanks and 40 sensors. Refer to the customer’s site design drawing for complete site-specific details on how many tanks and sensors are specified.

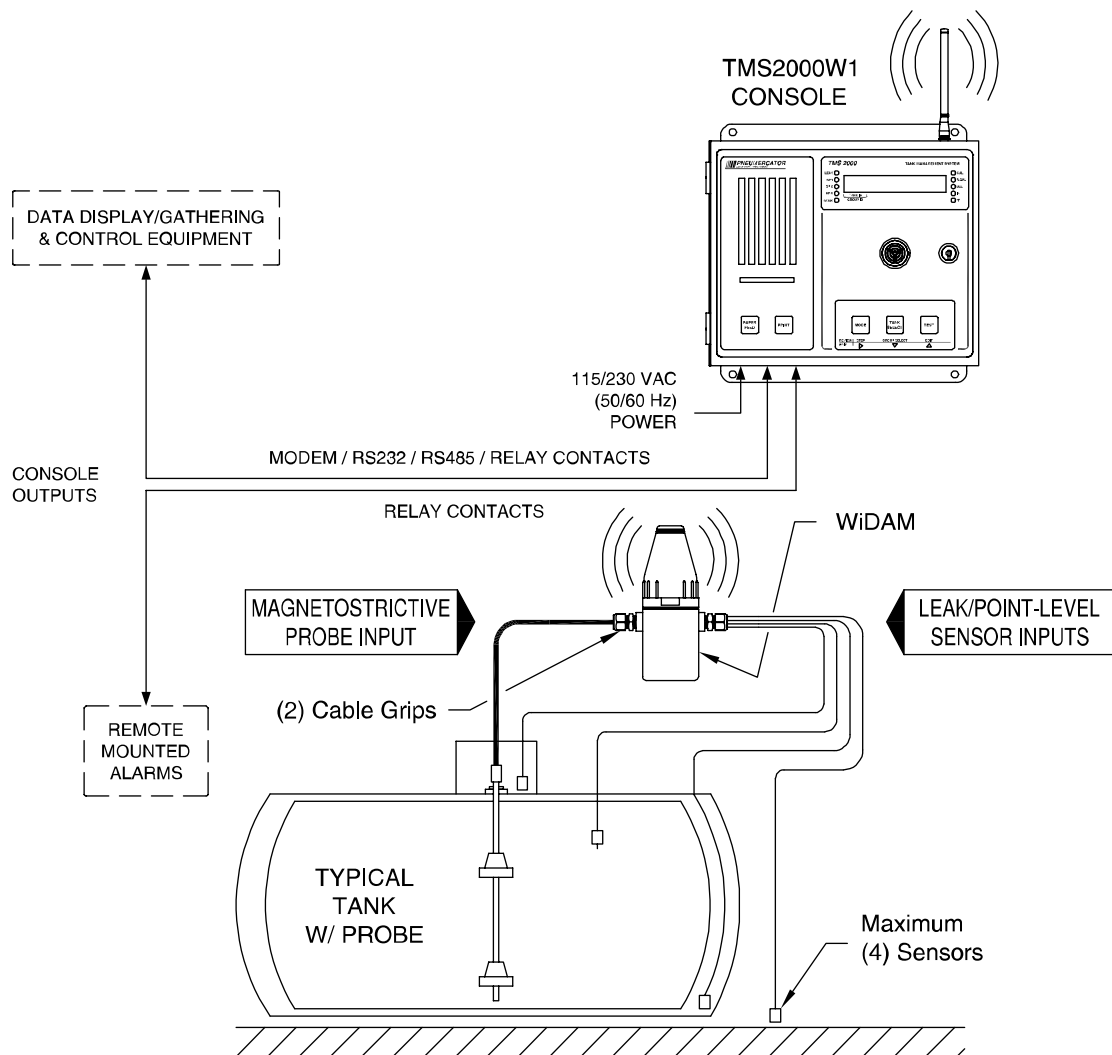

**Figure 1-1 - Typical System Block Diagram**

**1.2 CONTROL CONSOLE DESCRIPTION**

Figure 1-2 illustrates the TMS2000W outline and dimensions. All configurations are equipped with 1 RS-232 serial port, 1 RS-485 serial port, 2 fully programmable relay outputs/2 dry contact inputs, NEMA 12 enclosure. There are eight (8) basic configurations available:

Model Number	WiDAM Server	Display	Printer
TMS2000W1-1	Internal	No	No
TMS2000W1-2	Internal	Yes	No
TMS2000W1-3	Internal	Yes	Standard
TMS2000W1-4	Internal	Yes	Autowinder
TMS2000W2-1	External	No	No
TMS2000W2-2	External	Yes	No
TMS2000W2-3	External	Yes	Standard
TMS2000W2-4	External	Yes	Autowinder

The standard TMS2000W console enclosure is NEMA 12-rated for indoor installation. An optional NEMA 4/4X enclosure is available for outdoor installation. Confirm enclosure rating on the approval label located on the exterior, left-hand side of the enclosure before installation outdoors. See Figure 1-2 below for mounting flange locations and dimensions.

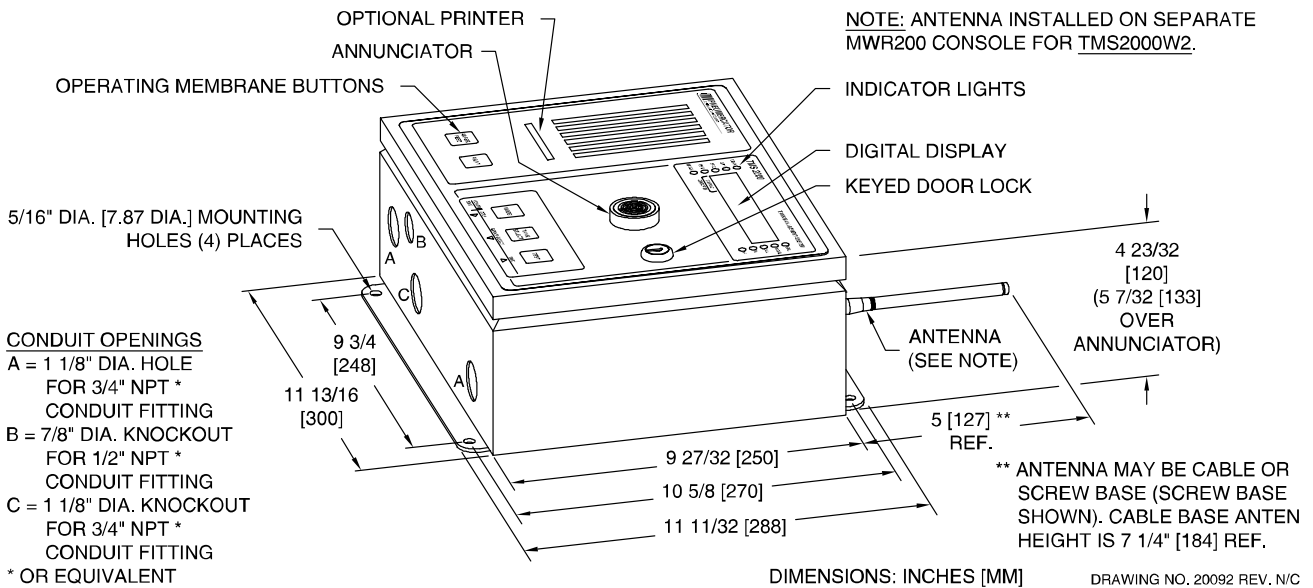

**Figure 1-2 - TMS2000 Console Outline**

**⚠ WARNING**

**The console is designed for Ordinary Location, Non-Hazardous installation only, as defined by Underwriters Laboratories (UL) and the National Electrical Code (NEC). DO NOT install where flammable vapors may be present. FAILURE TO COMPLY MAY RESULT IN PERSONAL INJURY, PROPERTY LOSS AND EQUIPMENT DAMAGE.**

The console should be located in an area that is easily accessible to the personnel responsible for operation and maintenance of the system. The antenna must be located where it has been confirmed to be able to communicate with the WiDAMs. Metal conduiting is recommended and may be required by local codes. All outdoor conduits must be watertight.

All conduit entries are provided on the bottom of the enclosure. Remove conduit knockouts only for those entries being used. If a knockout is removed but the entry will not be used, it must be sealed with an appropriate plug.

**⚠ WARNING**

**Do not drill or modify enclosure. Use only knockouts provided. FAILURE TO COMPLY WILL VOID WARRANTY AND MAY PRESENT A SAFETY HAZARD RESULTING IN PERSONAL INJURY, PROPERTY LOSS AND EQUIPMENT DAMAGE.**

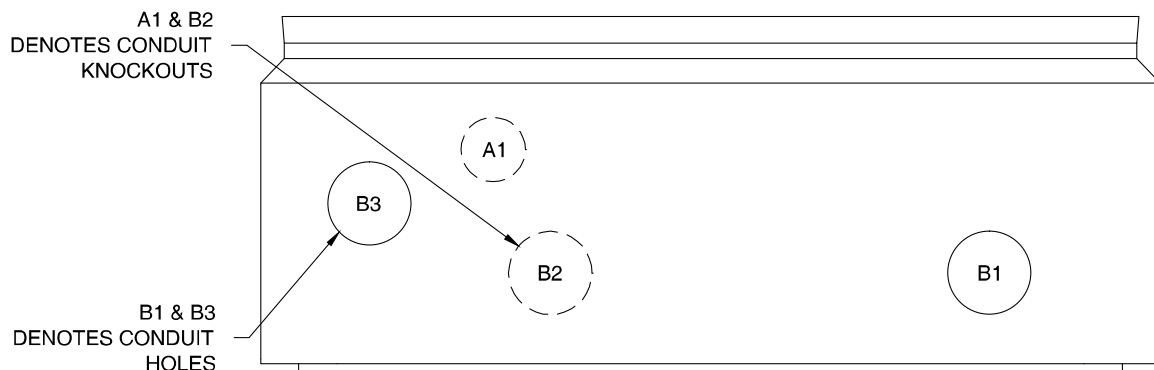

**CONDUIT OPENINGS AND DESIGNATED USES:**

1/2" NPT CONDUIT SIZE \*  
A1 = COMMUNICATIONS CABLES

3/4" NPT CONDUIT SIZE \*  
B1 = MWR200 CABLES (REQUIRED FOR TMS2000W2 ONLY; HOLE MUST BE PLUGGED FOR TMS2000W1)  
B2 = RELAY AND/OR ANALOG OUTPUTS

B3 = POWER \* OR EQUIVALENT

DRAWING NO. 20093 REV. N/C

**Figure 1-3 - TMS2000W Designated Conduit Locations**

### 1.3 WiDAM (Wireless Data Acquisition Module)

The WiDAM Wireless Data Acquisition Module accepts wiring for one magnetostrictive tank gauging probe and up to four secondary containment leak/point-level sensors (three 2 or 3-wire and one 2-wire), and wirelessly communicates probe/sensor data to the TMS2000W console. The WiDAM is housed in a NEMA 4X weatherproof and corrosion-proof enclosure suitable for installation within a hazardous-classified area. The location of the WiDAM should be carefully chosen to enable reliable communications to the TMS and to provide easy access to the probe and sensor cabling. Several mounting bracket kits are available for AST and UST installations.

## **⚠ WARNING**

**Installation MUST be done by qualified personnel familiar with local wiring codes and explosion hazard electrical safety practices. FAILURE TO COMPLY MAY RESULT IN PERSONAL INJURY, PROPERTY LOSS AND EQUIPMENT DAMAGE.**

Figure 1-4 – WiDAM Overview

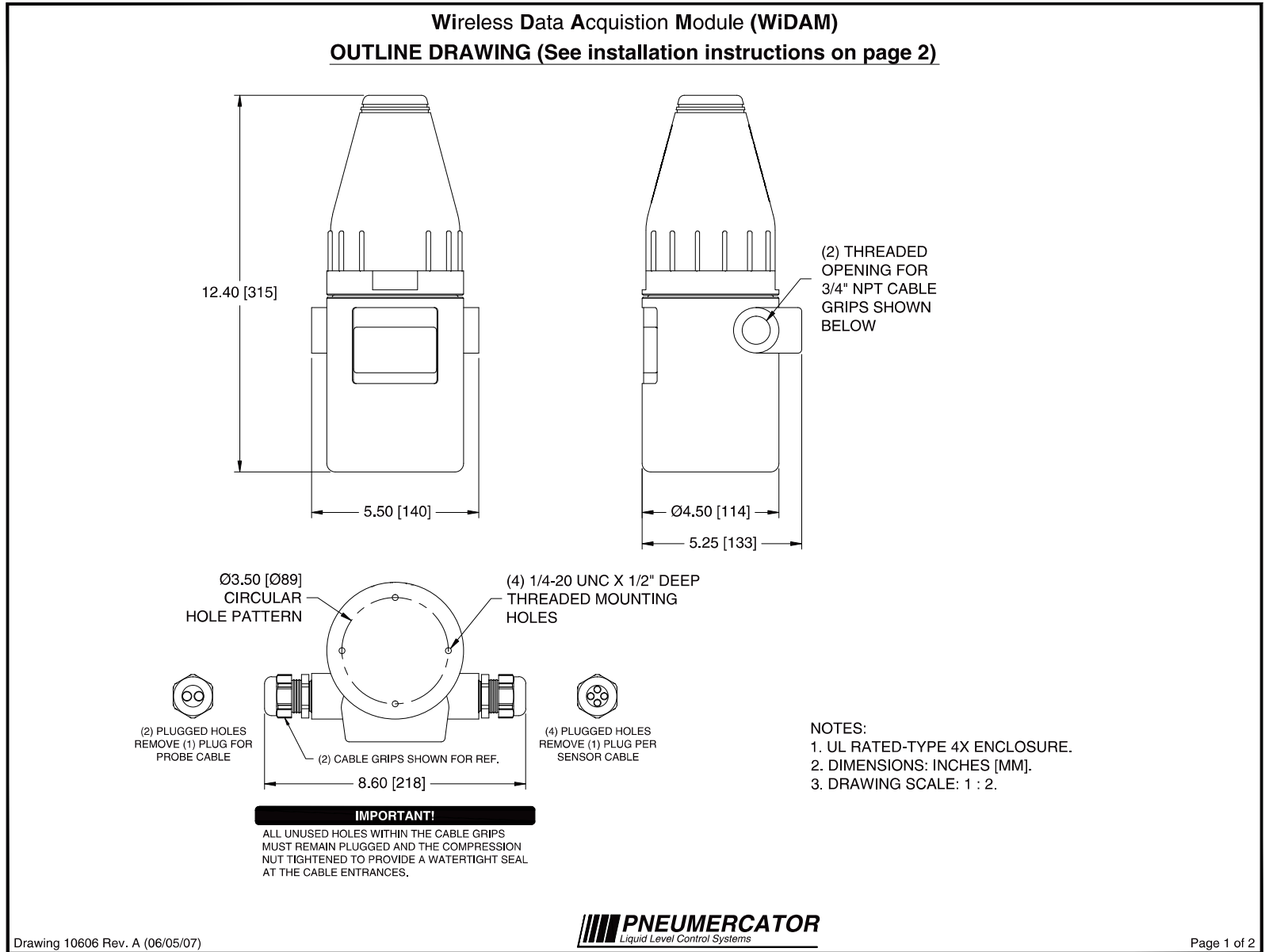

**1.3.1 LIQUID LEVEL PROBE DESCRIPTION**

TMS2000W can be supplied with four (4) types of magnetostrictive level probes:

Model MP550S – Inventory management on tanks up to 18”

Model MP551S – Inventory management on tanks 18’ – 24’

Model MP552S – Oil/Water separator tanks 1’ – 18’

Model MP56xS Series – Flex probe for low ceiling clearance or bulk storage tanks up to 70’

The following installation instructions cover the MP55xS Series. The MP56xS Series is covered in separate Instruction Bulletins.

Figure 1-5 shows the standard MP550S probe with dimensions and specifications. Note the standard probe requires a 4-inch female NPT tank fitting, and is supplied with a 6-foot cable; it does not include the RISER CAP, which must be ordered separately. Before installing, verify the model number matches the tank size intended, and that any accessories are available on site.

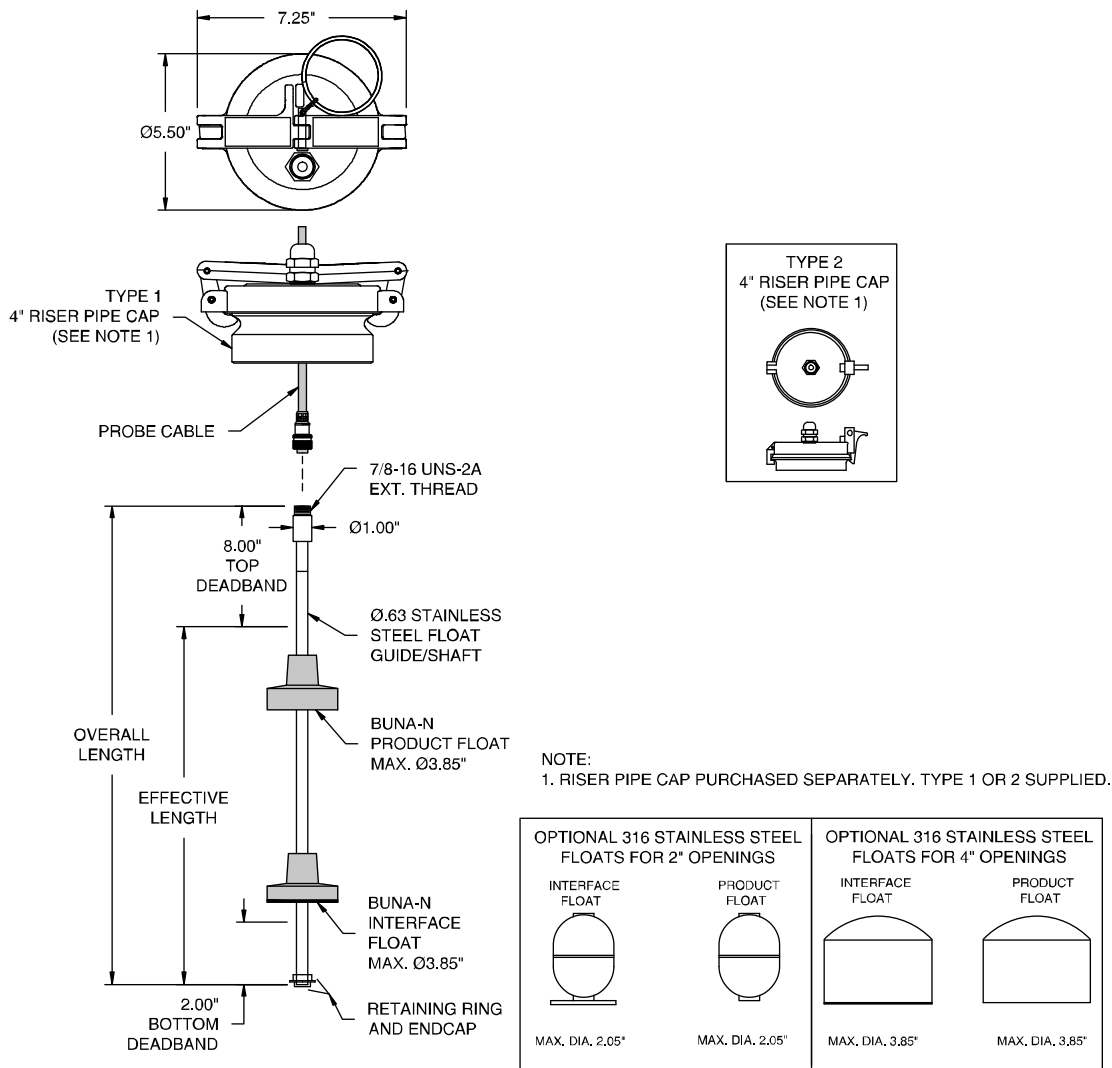

DRAWING NO. 20005 REV. E

**Figure 1-5 - Liquid Level Probe Outline**

**1.3.2 LIQUID LEAK SENSOR DESCRIPTION**

TMS2000W can be integrated with a variety of liquid sensors used for monitoring secondary containment areas around tanks and pipes. The maximum is 128 sensors (4 sensors per WiDAM, 32 WiDAMs) depending on the overall job configuration; check the specific job design drawings for the actual number and type specified. Figures 1-6 through 1-9 show four (4) sensor types available from Pneumercator with their most typical applications. Other non-Pneumercator models may be used; however, their use with TMS2000W should have been approved before attempting to wire them into the WiDAM.

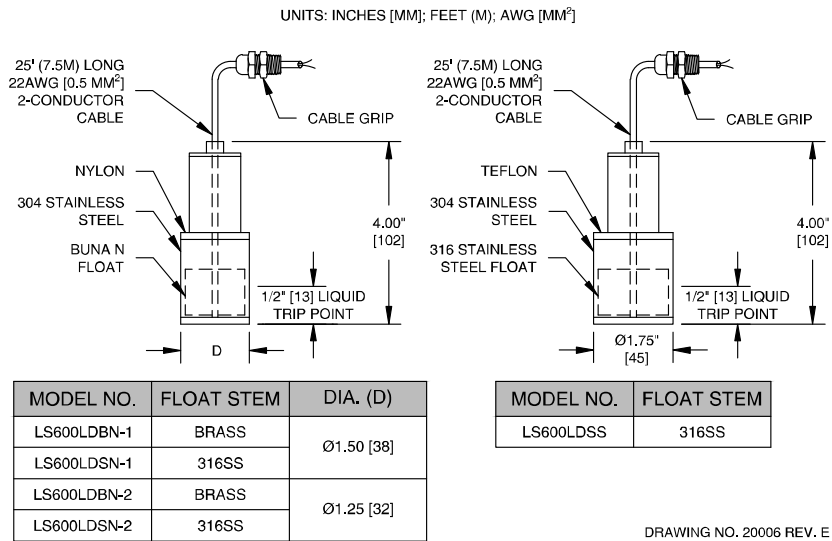

**Figure 1-6 – LS600 LD Series**

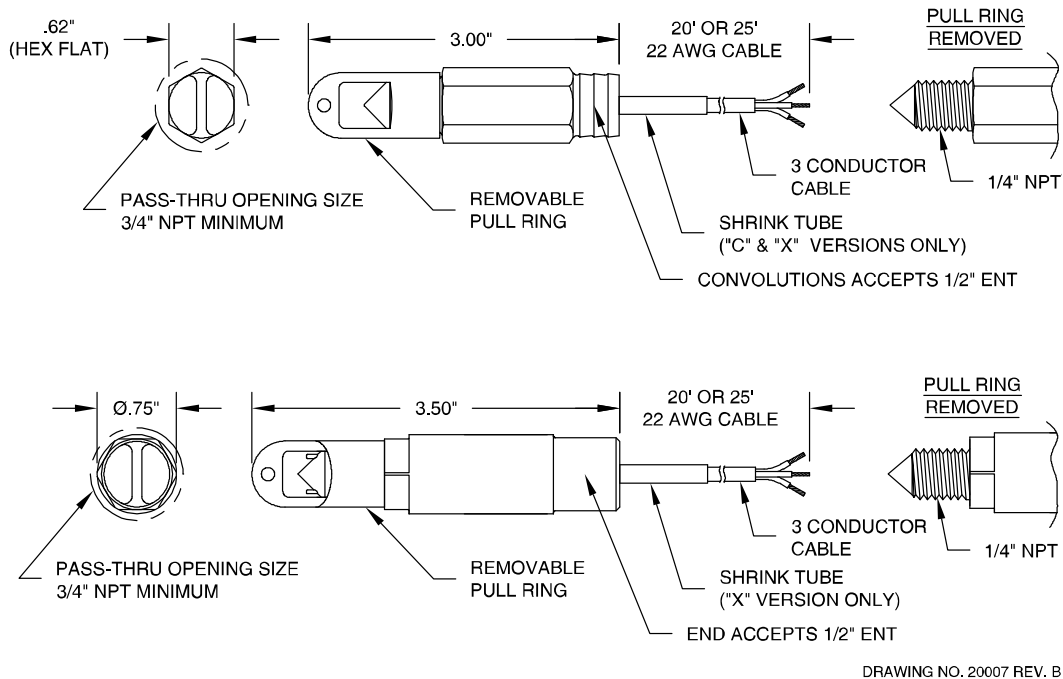

**Figure 1-7 – ES825-300F and ES825-400F (Max. 3 per WiDAM)**

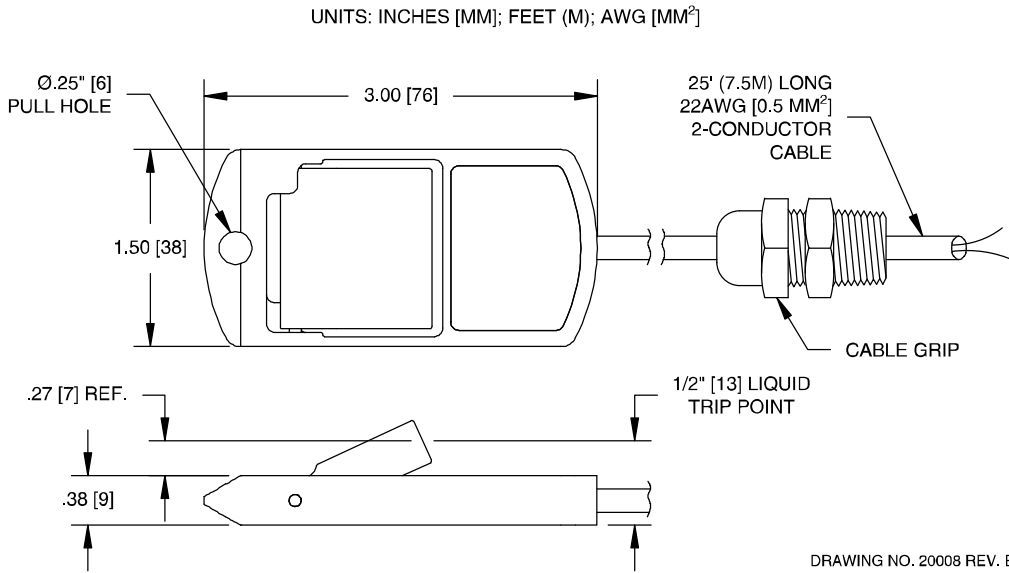

**Figure 1-8 – LS610**

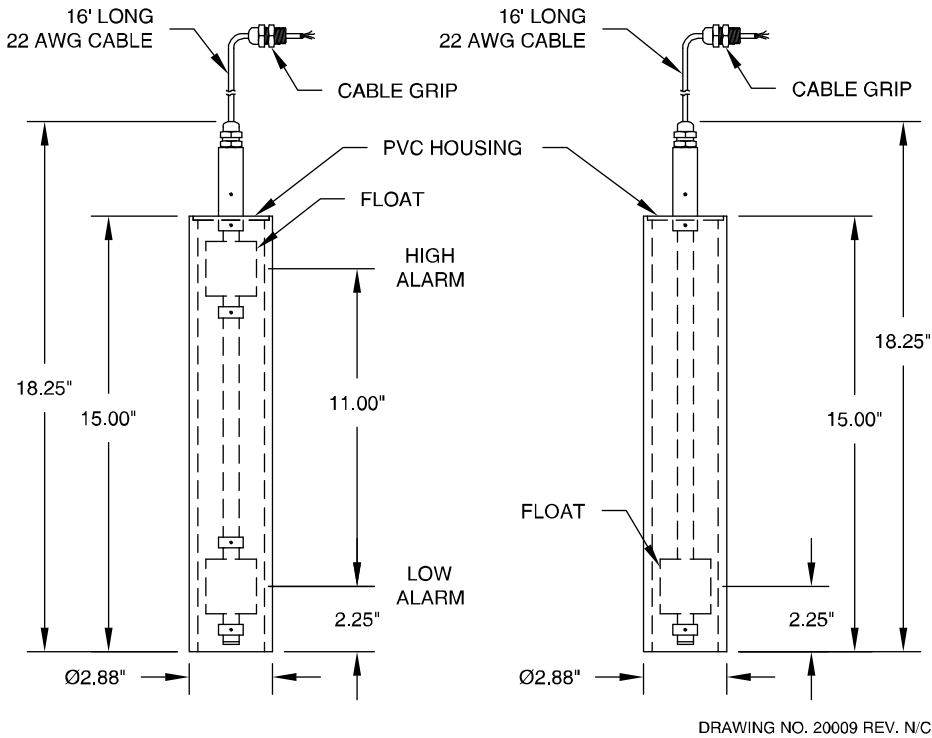

**Figure 1-9 – RSU800**

## SECTION 2 – INSTALLATION DETAILS

### 2.1 INSTALLATION CHECKLIST

#### **⚠ WARNING**

**Do NOT apply power to the TMS2000W until its installation has been checked and found to be in accordance with these instructions; National Electric Code; Federal, State and Local codes; and other applicable safety codes. FAILURE TO COMPLY MAY RESULT IN PERSONAL INJURY, PROPERTY LOSS AND EQUIPMENT DAMAGE.**

The following points should be reviewed in preparation for installation, and again when installation is complete.

1. Check that all equipment at job site matches the DESIGN DRAWING SPECIFICATIONS for the tank sizes and control features required.
2. System cannot be connected to equipment that uses or generates more than 250 volts with respect to earth.
3. The TMS ground must be terminated at the GND BUSS BAR in the same service panel as TMS power. A grounding rod, coldwater pipe or other connection should not be used. Refer to Figure 3-2 for illustrated details.
4. **Do not drill or modify enclosure.** Use only knockouts provided. Failure to comply will void warranty and may present a safety hazard.

**2.2 CONTROL CONSOLE INSTALLATION**

The console is the center of operations for any tank monitor system; therefore its location should be selected for the operators' convenience, or as specified on the DESIGN DRAWINGS. The antenna must be located in an area confirmed to communicate with the WiDAMs. Although line of site is preferred, it is not required to establish reliable communications.

Select a flat wall surface and prepare it with four wall-mounting inserts to accept up to 1/4-inch size bolts. Allow sufficient room for door to open and for conduit runs to enter **ONLY THE CONSOLE BOTTOM**. See Figure 1-2 for console dimensions.

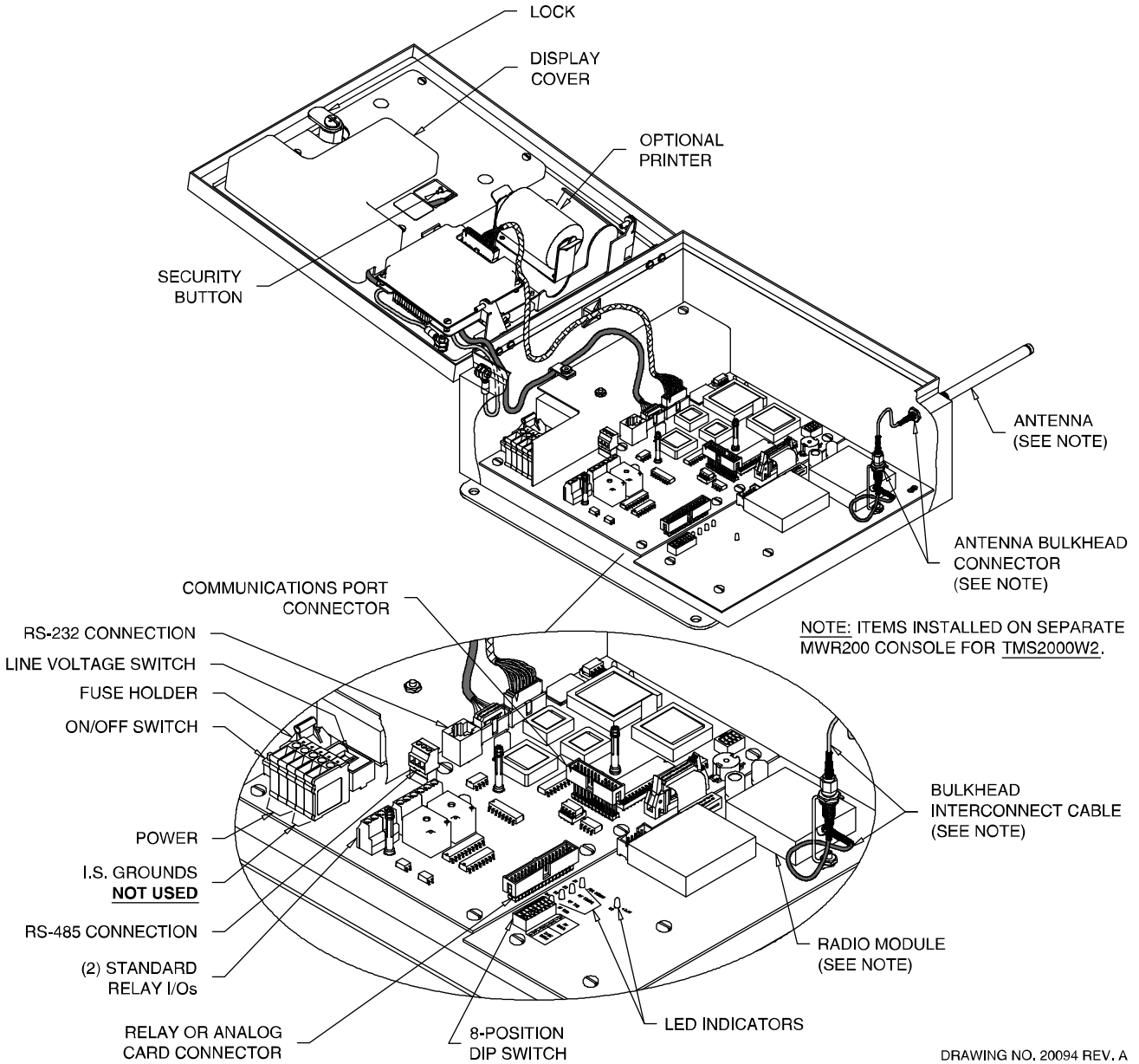

**Figure 2-1 - Control Console Interior**

### 2.3 WiDAM INSTALLATION

The WiDAM can support 1 magnetostrictive probe and up to 4 leak/point level sensors; therefore its location should be selected for optimum antenna placement and minimum cable distance, or as specified on the DESIGN DRAWINGS. The antenna must be located in an area confirmed to communicate with the TMS2000W. Although line of site is preferred, it is not required to establish reliable communications.

There are 3 main methods of mounting the WiDAM as illustrated in Figure 2-2.

**Wireless Data Acquisition Module (WiDAM)  
INSTALLATION INSTRUCTIONS (See outline drawing on page 1)**

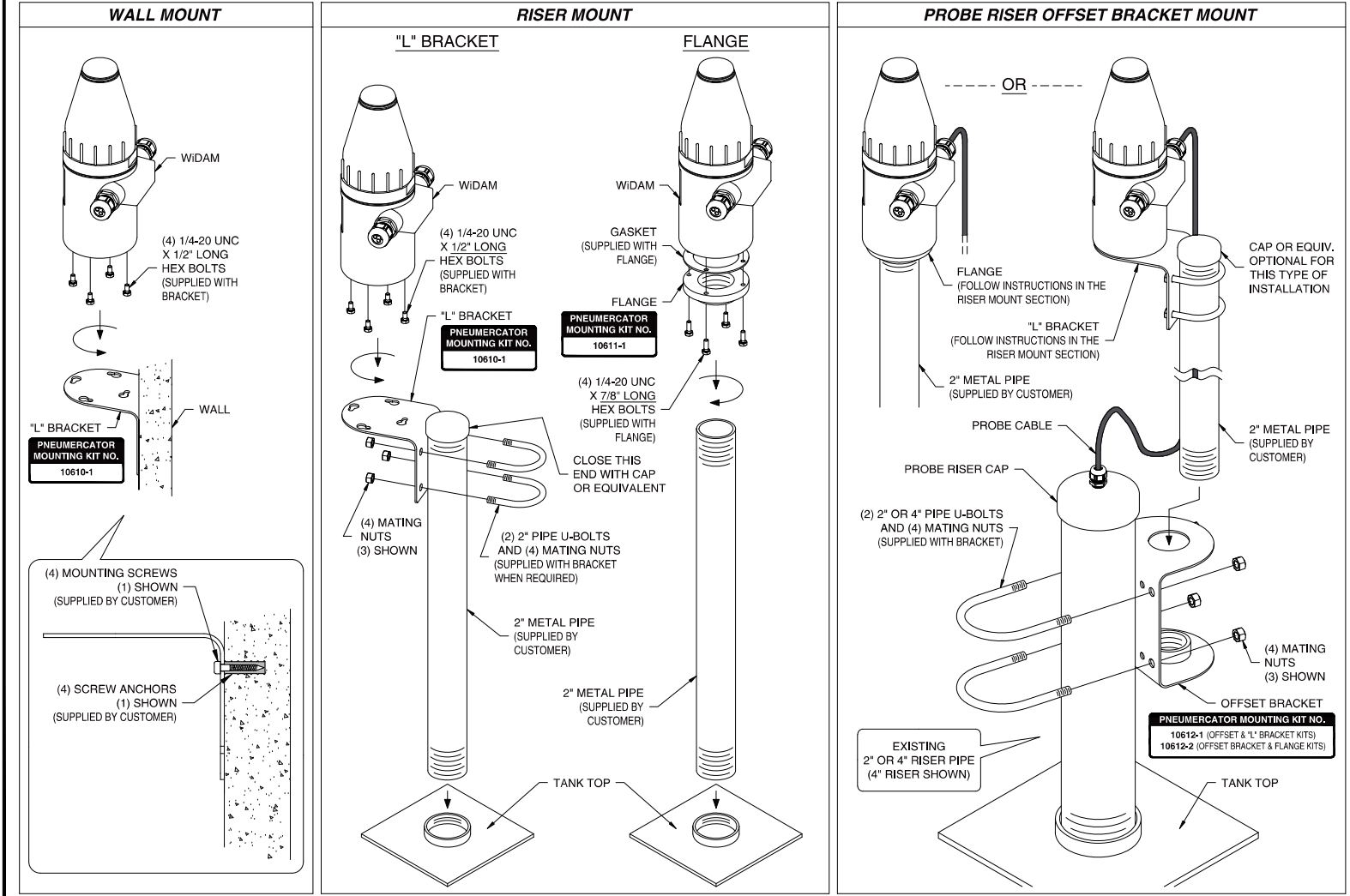

NOTE: MOUNTING KITS ARE AVAILABLE SEPARATELY.

Drawing 10606 Rev. A (06/05/07)

Page 2 of 2

Figure 2-2 – WiDAM Mounting Options

**2.4 LEVEL PROBE INSTALLATION IN UNDERGROUND TANKS**

Installing the magnetostrictive level probe underground is similar for both STEEL and FIBERGLASS tanks. Refer to Figure 2-3. The tank top must be equipped with an access MANHOLE containing a probe RISER PIPE supplied by the installer. The manhole should be at least 18 inches in diameter and a height suitable for the tank burial depth. The riser should have a 2 to 4-inch pipe opening. The tank opening must be fitted with a schedule 40 RISER PIPE cut to length to provide the minimum height of 18 inches shown measured from the TANK TOP (ID) to the probe's RISER CAP. The level probe's electronic housing will reside "inside" the riser. The riser top should be NPT male threaded and allow a clearance of at least 6 inches to the underside of the manhole cover. This will provide enough space for the riser cap and probe cable. For riser caps not supplied by Pneumercator, the cap must have a 1/2-inch NPT tapped hole for probe cable passage.

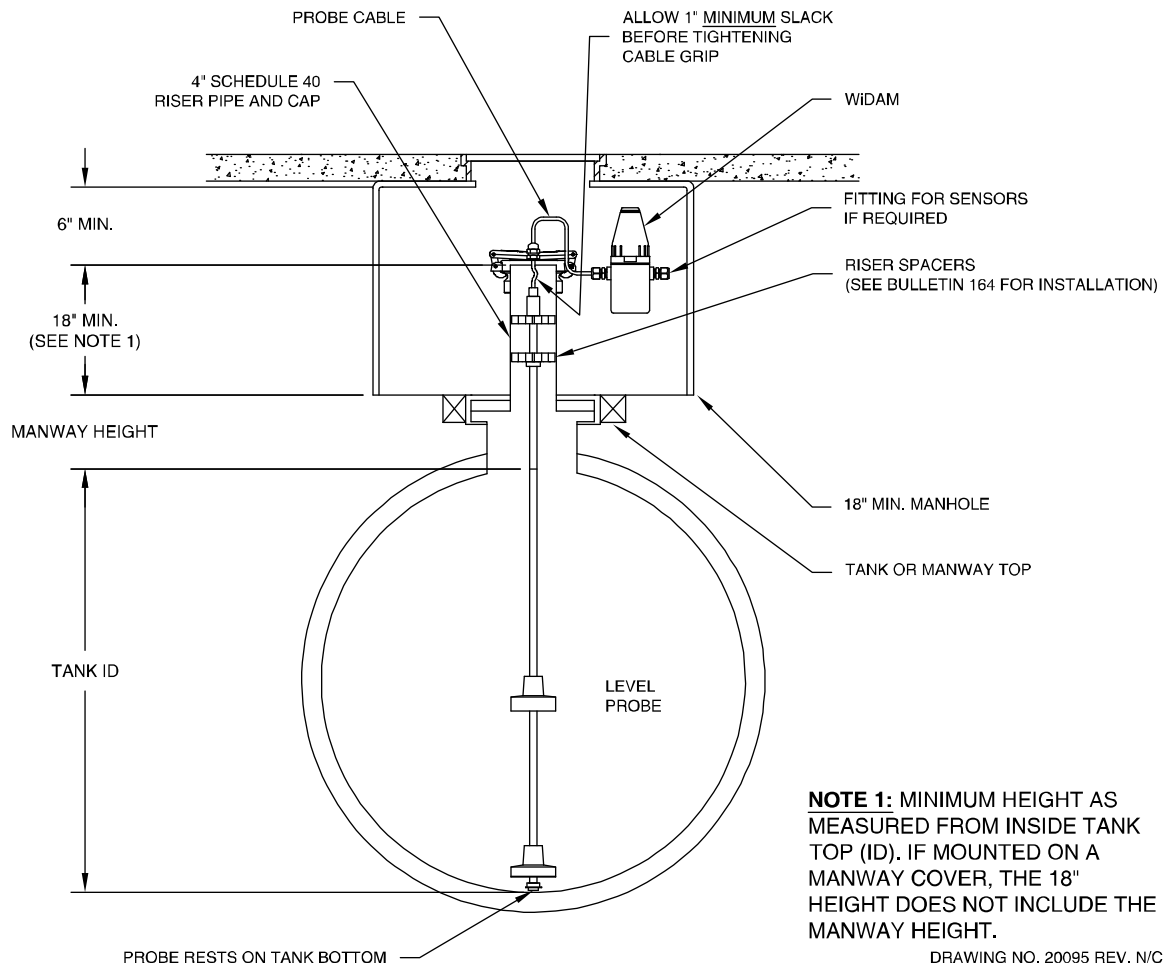

**Figure 2-3 - Level Probe Installation - Underground Tank**

**ASSEMBLY INSTRUCTIONS - RISER MOUNTED MODEL:**

MP42xS
MP45xS MP55xS

**IMPORTANT! ALL of the following requirements must be met;**

- Probe length does not exceed 15 feet.
- Tank **does not** contain chemicals, solvents or heated products where standard leader cable is used.
- Tank **does** contain chemical, solvent or heated products where chemical/heat resistant probe assembly and leader cable are used and confirmed to be compatible with stored product.
- Tank is not pressurized.

**Questions? Contact Technical Support at (800) 209-7858**

*FOR INSTALLATION AND WIRING SEE TMS MANUAL*

<p><b>1</b> Confirm you were supplied the correct number of floats (1 or 2). A Probe P/N with "21" or "25" suffix requires DUAL (2) floats while "11" or "15" suffix requires a SINGLE (1) float. Contact Pneumercator immediately if supplied Probe and number of floats do not match.</p>	<p><b>4</b> Assemble riser spacers.</p> <p><b>NOTE:</b> AT THIS POINT MODEL MP452S/MP552S ASSEMBLY IS COMPLETE. PROCEED TO STEP 5 TO COMPLETE ASSEMBLY FOR ALL OTHER MODELS.</p>
<p><b>2</b> Trim spacers for the desired schedule 40 riser pipe diameter.</p>	<p><b>3</b> Verify that the <u>bottom</u> of the locking collar is located 8" from the top of the probe head and confirm that collar is secured.</p>

5 <u>4" RISER MOUNTING ASSEMBLY</u>	<u>2" RISER MOUNTING ASSEMBLY</u>			
<u>STANDARD APPLICATIONS</u>	<u>STANDARD APPLICATIONS WITH INTERFACE *</u>	<u>WITHOUT INTERFACE</u>	<u>CHEMICAL APPLICATIONS WITH INTERFACE *</u>	<u>WITHOUT INTERFACE</u>
<p>PRODUCT FLOAT OPTIONAL INTERFACE FLOAT * METAL WEIGHT CATHODIC BOOT RETAINING RING END CAP</p>	<p>PRODUCT FLOAT INTERFACE FLOAT METAL WEIGHT CATHODIC BOOT SPACER RETAINING RING END CAP</p>		<p>S.S. COLLAR FLUSH WITH BOTTOM OF PROBE SHAFT</p>	<p>1/2"</p> <p>S.S. COLLAR</p>
			* NOT APPLICABLE FOR MP42xS	



**Figure 2-4 - Probe Assembly Instructions - Riser Mount**

Install the level probe in the UNDERGROUND TANK as follows:

1. Select the correct probes for the tank. Match the model number with tank internal dimensions per Figure 1-5.
2. Assemble the probe per Bulletin 164 shown in Figure 2-4.
3. Slowly lower probe into tank opening until probe's FOOT REST is on the tank bottom. The probe should be vertical with both centering spacers totally supported within the riser pipe.
4. Feed the probe cable through the underside of the riser cap cord grip supplied. Keep the grip loose so cable can be flexed. Leave enough slack beneath the cap so the probe rests on the tank bottom, and above the cap to reach the electrical junction box in the manhole.
5. Prepare riser pipe and cap with pipe dope or suitable compound, and carefully mate them together.
6. Tighten the cable cord grip on top of the riser cap to ensure a WATERTIGHT SEAL.
7. Route the probe cable to the WiDAM and complete the wiring installation in accordance with Section 3.

## **2.5 LEVEL PROBE INSTALLATION IN ABOVEGROUND TANKS**

NOTE: For tanks located inside buildings or vaults, or under outdoor containment shelters:

Rigid Level Probes models MP550S, MP551S, & MP552S require tank headroom clearance at least equal to overall probe length for insertion and removal. See Figure 1-5 for probe dimensions.

There are two methods of installing the level probe in aboveground tanks shown in Figures 2-5 and 2-6. The choice is dictated by the actual fitting supplied integral to the probe.

The standard method shown in Figure 2-5 uses a RISER PIPE mounted on top of the tank to support the probe; similar to an underground tank installation. The optional method shown in Figure 2-6 employs a REDUCER FITTING to support the probe.

Risers and reducers are SUPPLIED BY THE INSTALLER.

### 2.5.1 RISER PIPE METHOD FOR ABOVEGROUND TANKS

Tank openings must be fitted with a schedule 40 RISER PIPE cut to length to provide the minimum height of 18 inches shown measured from the TANK TOP to the probe's RISER CAP. Both of the level probe's centering spacers will reside "inside" the riser.

The riser top should be NPT male threaded and allow a clearance of at least 6 inches to the underside of any roof cover that may be added after probe installation. This will provide enough space for the riser cap and probe cable. For riser caps not supplied by Pneumercator, the cap must have a 1/2-inch NPT tapped hole for probe cable passage.

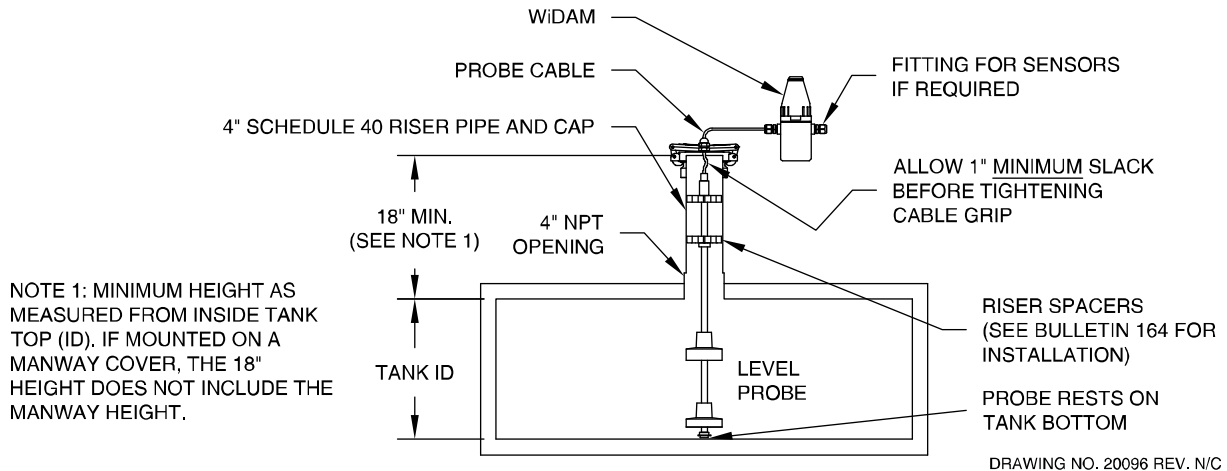

**Figure 2-5 - Riser Pipe Mounting Aboveground Tanks**

Install the level probe per Figure 2-5 as follows:

1. Select the correct probe for the tank. Match the model number with tank internal dimensions per Figure 1-5.
2. Assemble the probe per Bulletin 164 shown in Figure 2-4.
3. Slowly lower probe into tank opening until probe's FOOTREST is on the tank bottom. The probe should be vertical with both centering spacers totally supported within the riser pipe.
4. Feed probe cable through the underside of the riser cap cord grip supplied. Keep the grip loose so cable can be flexed. Leave enough slack beneath the cap so the probe rests on the tank bottom, and above the cap to reach the electrical junction box.
5. Prepare riser pipe and cap with pipe dope or suitable compound, and carefully mate them together.
6. Tighten the cable cord grip on top of the riser cap to ensure a WATERTIGHT SEAL.
7. Route the probe cable to the WiDAM and complete the wiring installation in accordance with Section 3.

## 2.5.2 BUSHING OR FLANGE MOUNT METHOD FOR ABOVEGROUND TANKS

This method is employed for large vertical tanks and heated, pressurized, or chemical applications but may also be used for standard 2, 3 and 4-inch openings when it is not desired to enclose the electronic housing within a pipe riser. The level probe will "hang" inside the tank at a fixed position supported by the tank-mounting fitting.

Because the probe is fixed to the mounting fitting, it is critical during installation to allow a 1-INCH BOTTOM CLEARANCE between the probe's FOOT REST and tank bottom or strike plate. This will prevent the probe touching the tank bottom during tank expansion and contraction. The 1-inch clearance dimension is standard and has been properly accounted for in the probe's manufacture.

The customer must supply an appropriate mounting fitting to mate with the tank opening, if less than 2 inches, to accommodate the PK2-DM Direct Mount Probe Kit. Assembly is as illustrated in Figure 2-7.

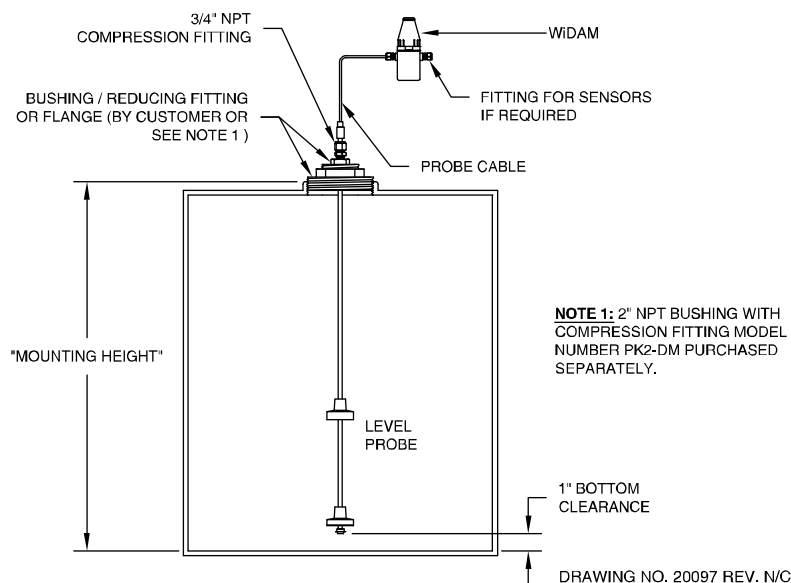

**Figure 2-6 - Reducer Fitting or Flange Mounting for Aboveground Tanks**

Install the level probe per Figure 2-6 as follows:

1. Select the correct probe for the tank. Match the model number with the tank internal dimensions per Figure 1-5.
2. Remove the probe from its shipping container. Remove all packing material.
3. Slowly lower the probe into tank opening. The probe should be vertical with its electronic housing totally visible above the tank fitting. When the probe touches the bottom, screw the bushing into the tank. **DO NOT** tighten the compression fitting at this time. Mark the shaft and lift the probe up 1 INCH.
4. Tighten the cable connector on top of the probe housing to ensure a **WATERTIGHT SEAL**.
5. Route the probe cable to the WiDAM and complete the wiring installation in accordance with Section 3

**ASSEMBLY INSTRUCTIONS - DIRECT MOUNTED MODEL:**

<b>MP42xS</b>	
<b>MP45xS</b>	<b>MP55xS</b>

**Applies to the following installations;**

- Probe lengths exceeding 15 feet.
- Chemical, solvent or heated tanks using standard leader cable.
- Pressurized tanks. Consult with Technical Support for pressure limits.

**Questions? Contact Technical Support at (800) 209-7858**

*FOR INSTALLATION AND WIRING SEE TMS MANUAL*

- 1 Confirm you were supplied the correct number of floats (1 or 2). A Probe P/N with "21" or "25" suffix requires DUAL (2) floats while "11" or "15" suffix requires a SINGLE (1) float. Contact Pneumercator immediately if supplied Probe and number of floats do not match.
- 2 The top of the probe is an unengageable deadband. Verify that the probe is of sufficient length so that the float's magnet will not travel into this deadband.

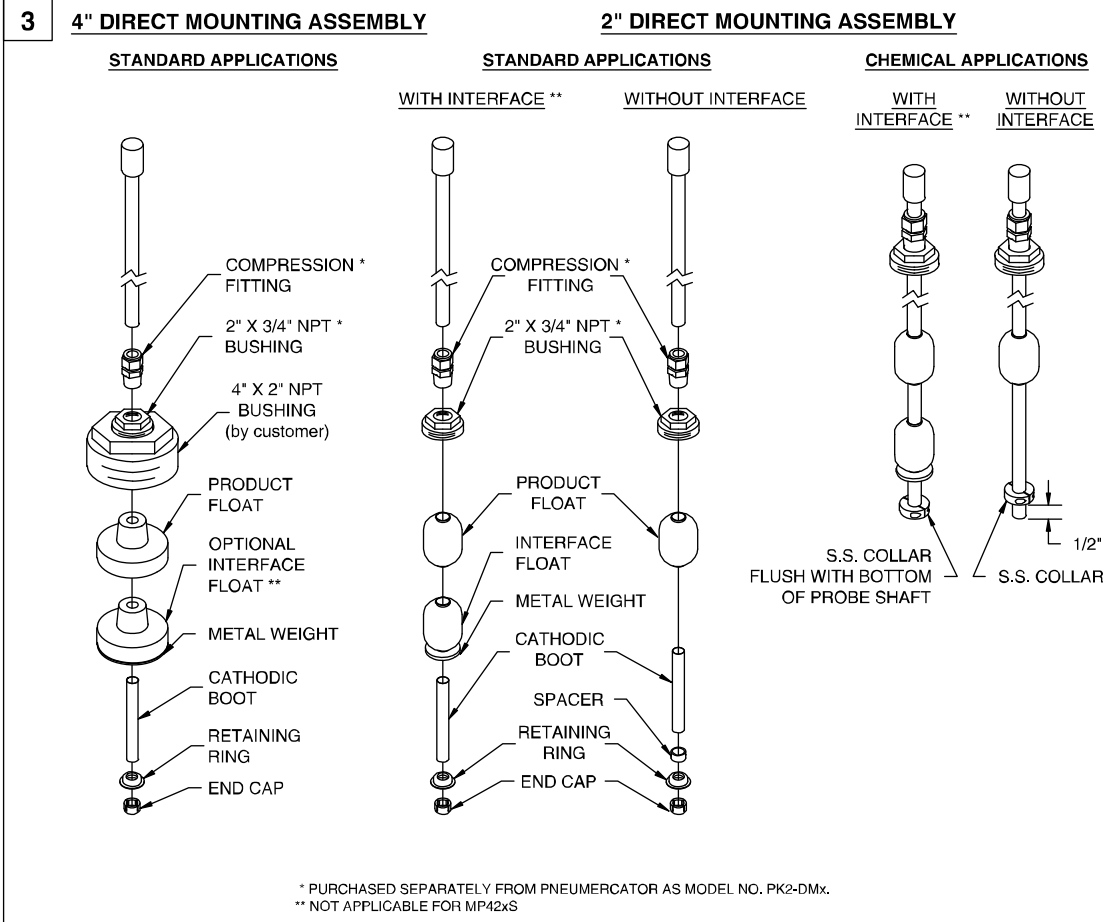
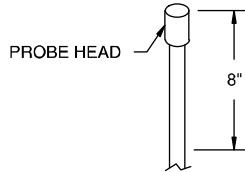

**Figure 2-7 – MP55xS Probe Assembly Instructions - Direct Mount**

## EXTERNAL LEAK SENSOR INSTALLATION

The interstitial or double-wall space of steel tanks and vaulted tanks as well as many other secondary containment areas can be fitted with either DISCRIMINATING or NON-DISCRIMINATING leak sensors. Also, for float type non-discriminating sensors, switch actuation may be factory set for either NORMALLY OPEN or NORMALLY CLOSED.

### 2.6 LEAK SENSOR INSTALLATION IN STEEL AND VAULTED TANKS

Check the specific design drawings for the job, or choose the sensor type desired from Figures 1-6 and 1-7. Install sensor per Figure 2-8 as follows:

1. Remove the watertight CORD CONNECTOR supplied by sliding it off the sensor cable.
2. Thread the watertight CONNECTOR into the top of a 2" by 1/2" reducer bushing or monitor pipe cap pre-tapped for a 1/2" NPT hole. (The use of any standard monitor cap from 2" to 4" pipe size is recommended. The cap or reducer bushing IS NOT SUPPLIED with the sensor and must be provided by the installer. The monitor cap is sold separately as part number SK2 for 2-inch openings or SK4 for 4-inch openings.).
3. Measure the "MOUNTING HEIGHT" from top to bottom of monitoring pipe.
4. Feed the sensor cable through the watertight CONNECTOR from the BOTTOM SIDE of the REDUCER (or CAP) fitting to a cable length suitable for the MOUNTING HEIGHT; or to allow sensor to rest on the monitor pipe bottom; or as required by local codes. Cable may be cut or extended to proper length.
5. Re-tighten the CORD CONNECTOR to fix the sensor cable length.
6. Mate the REDUCER or CAP to the top of the monitor pipe. Tighten the CONNECTOR to ensure a WATERTIGHT SEAL.
7. Route the sensor cable to the WiDAM and complete the wiring installation in accordance with Section 3.

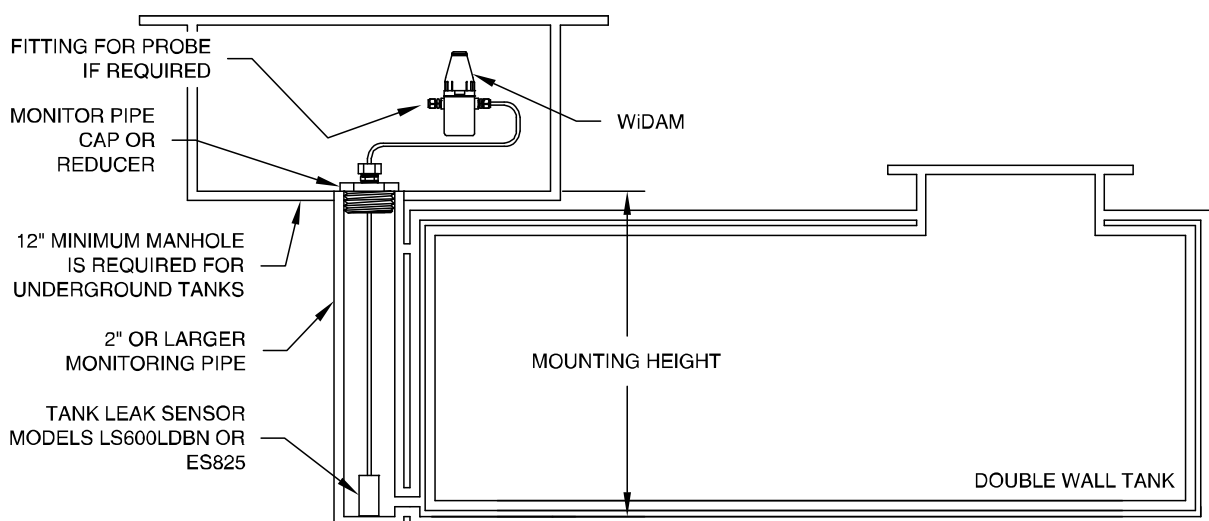

DRAWING NO. 20098 REV. N/C

Figure 2-8 - Leak Sensor Installation - Steel Vaulted Tanks

## 2.7 LEAK SENSOR INSTALLATION IN PIPING SUMPS AND DISPENSER PANS

Check the specific design drawings for the job, or choose the sensor type desired from Figures 1-6 and 1-7. Install sensor per Figure 2-9 as follows:

1. Measure the MOUNTING HEIGHT from conduit or junction box to the bottom of the SUMP (or MANHOLE, VAULT or DISPENSER PAN).
2. Feed the sensor cable through the watertight CONNECTOR to length suitable for the MOUNTING HEIGHT; or to allow sensor to rest on the containment bottom; or as required by local codes. Feed an additional 12 inches past the CONNECTOR for splicing inside the junction box; cable may be cut to proper length.
3. Thread the CONNECTOR into the WATERTIGHT JUNCTION BOX and tighten the CONNECTOR cord grip over the cable to insure a WATERTIGHT SEAL. The sensor should rest on the containment floor or as required by local codes.
4. Route the sensor cable to the WiDAM and complete the wiring installation in accordance with Section 3.

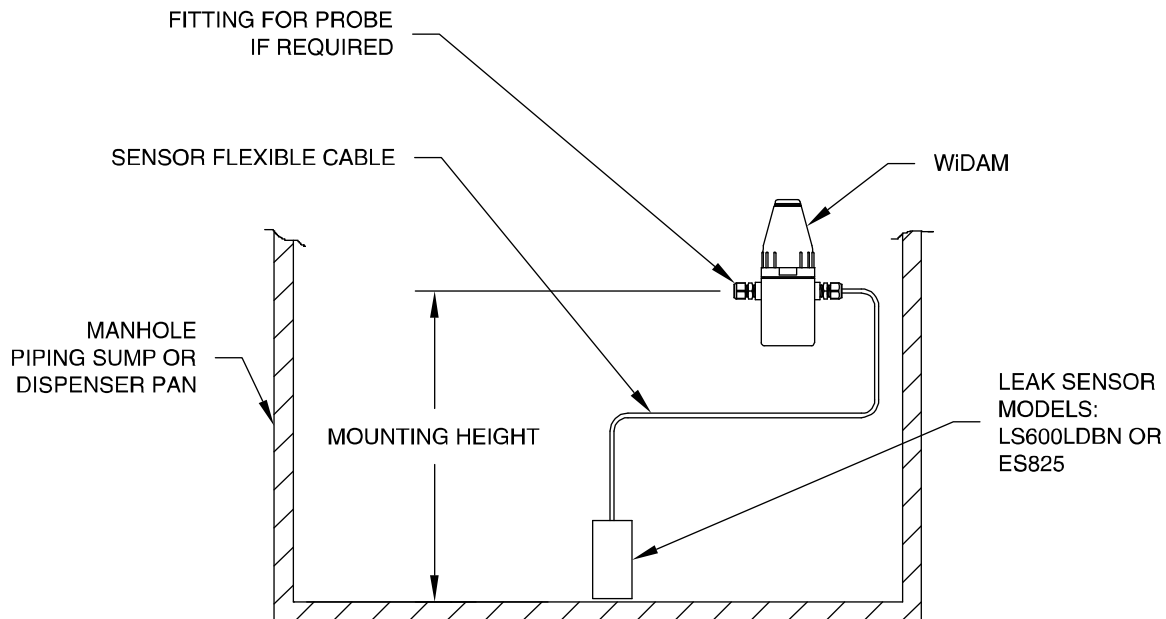

DRAWING NO. 20099 REV. N/C

**Figure 2-9 - Leak Sensor Installation in Piping Sumps, Manholes, and Dispenser Pans**

## 2.8 LEAK SENSOR INSTALLATION IN FIBERGLASS TANK ANNULUS

The annular space of fiberglass tanks can be fitted with either a DRY ANNULUS type sensor, models ES825 (Figure 1-7) and LS610 (Figure 1-8), or a WET RESERVOIR sensor model RSU800 (Figure 1-9). The wet reservoir is also referred to as the HYDROSTATIC METHOD. Check the specific design drawings for the job, or choose the type sensor desired from Figures 1-7 through 1-9. Install sensor per Figures 2-10 or 2-11.

Instructions per Figure 2-10, DRY ANNULUS SENSOR:

1. Calculate the sensor cable's MOUNTING LENGTH from tank size data so the sensor rests at tank bottom; or use the following method.

Determine the cable's MOUNTING LENGTH by adding the cable measurement M from the table at the right to the RISER HEIGHT. Mark the cable at that length. **DO NOT CUT THE CABLE.**

2. Remove the watertight CORD CONNECTOR supplied by sliding it off the cable.
3. Thread the CONNECTOR into the top of a 2" by 1/2" reducer bushing or riser pipe cap pre-tapped for a 1/2" NPT hole. (The use of any standard monitor cap from 2" to 4" pipe size is recommended. The cap or reducer bushing IS NOT SUPPLIED with the sensor and must be provided by the installer. The monitor cap is sold separately as part number SK2 for 2-inch openings or SK4 for 4-inch openings.)

### CABLE MEASUREMENT FROM END OF SENSOR

Tank Dia.	Cable M
4 Feet	81 in.
6 Feet	118 in.
8 Feet	150 in.
10 Feet	194 in.
12 Feet	222 in.

4. At riser top, attach the annular space PULL CORD (this is part of the tank supplier's pre-installed accessories) to the sensor's PULL HOLE.
5. Pull the free end of the PULL CORD out of the riser while feeding the sensor into the riser and through the annular space until the sensor is at the bottom centerline of the tank. The MOUNTING LENGTH MARK should be about 5 INCHES above the open riser. Adjust its position as necessary and, without disconnecting the PULL CORD, coil its excess inside the riser pipe.
6. Feed the sensor cable through the BOTTOM of the riser cap (or bushing), and through the CORD CONNECTOR while positioning cap over the riser pipe. Mate riser and cap.
7. Tighten CONNECTOR over the cable to ensure a WATERTIGHT SEAL.
8. Route the sensor cable to the WiDAM and complete the wiring installation in accordance with Section 3.

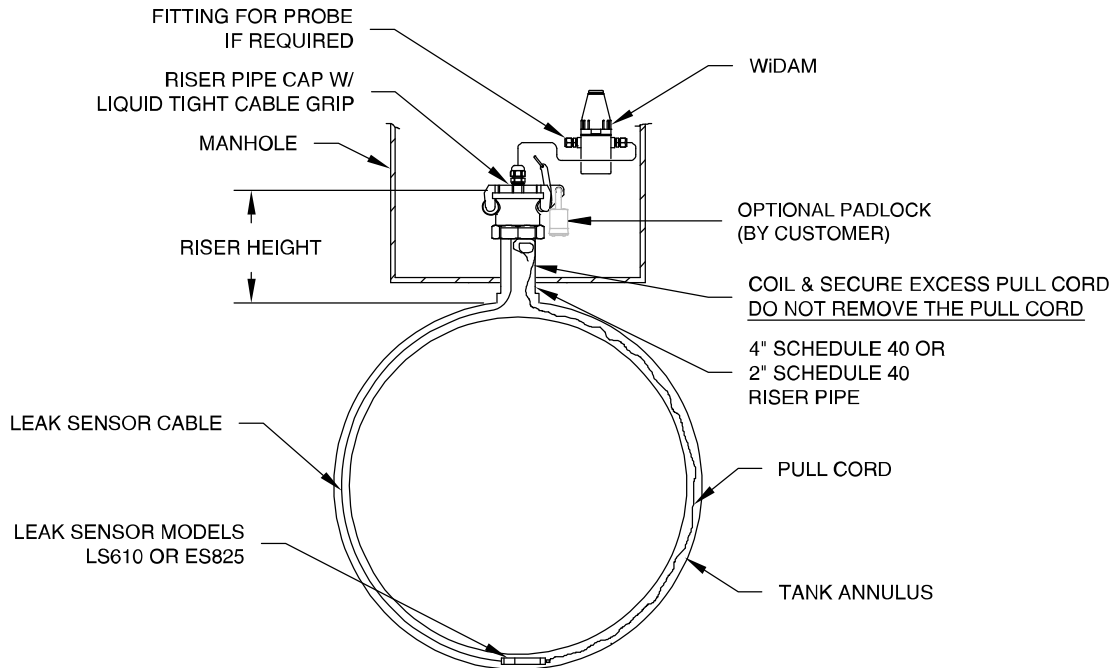

Figure 2-10 - Dry Leak Sensor Installation in Fiberglass Tank

## 2.9 HYDROSTATIC LEAK SENSOR INSTALLATION IN FIBERGLASS TANK RESERVOIRS

The model RSU800 sensor uses a dual float that senses a HIGH and LOW liquid level within the reservoir. If a tank leak occurs through either wall of the DOUBLE-WALL tank the liquid level in the reservoir changes. When it reaches the upper or lower limits of the sensor a contact closure is transmitted to the control console.

Instructions per Figure 2-11, HYDROSTATIC LEAK SENSOR:

1. The tank reservoir should be fitted with a 4 inch RISER PIPE, supplied by THE INSTALLER. A vented monitor cap is sold separately as part number SK4V. The riser should be at least 12 inches long as measured from the reservoir opening. The riser cap may be any standard type, but as a minimum it should have a 3/8" NPT tapped hole to accept the CORD GRIP CONNECTOR SUPPLIED BY PNEUMERCATOR, or contain its own suitable cord grip. (An alternate method is to drill and tap the wall of the riser pipe). The use of a riser cap with a VENT TUBE is only recommended where local installation requires one.
2. If the riser cap does not contain its own cord connector, thread the PNEUMERCATOR SUPPLIED CONNECTOR into the tapped hole using sealing compound as required. (Alternately, the CONNECTOR may be threaded into the sidewall of the riser).
3. Slowly lower the sensor into the riser until it rests on the reservoir bottom. The top portion should extend into the riser pipe for support from tipping over. The liquid level in the reservoir should be at about 7 inches up the sensor's height for optimum performance. (See Figure 1-9 for float travel set point limits).

4. Feed the sensor cable through the **BOTTOM** of the riser cap (or pipe wall), and through the **CORD CONNECTOR**. Leave just enough slack inside the riser pipe so the sensor remains on the bottom, and will not tip over.
5. Mate the riser and cap; tighten the **CONNECTOR** over the cable to ensure a **WATERTIGHT SEAL**.
6. Route the sensor cable to the **WiDAM** and complete the wiring installation in accordance with Section 3.

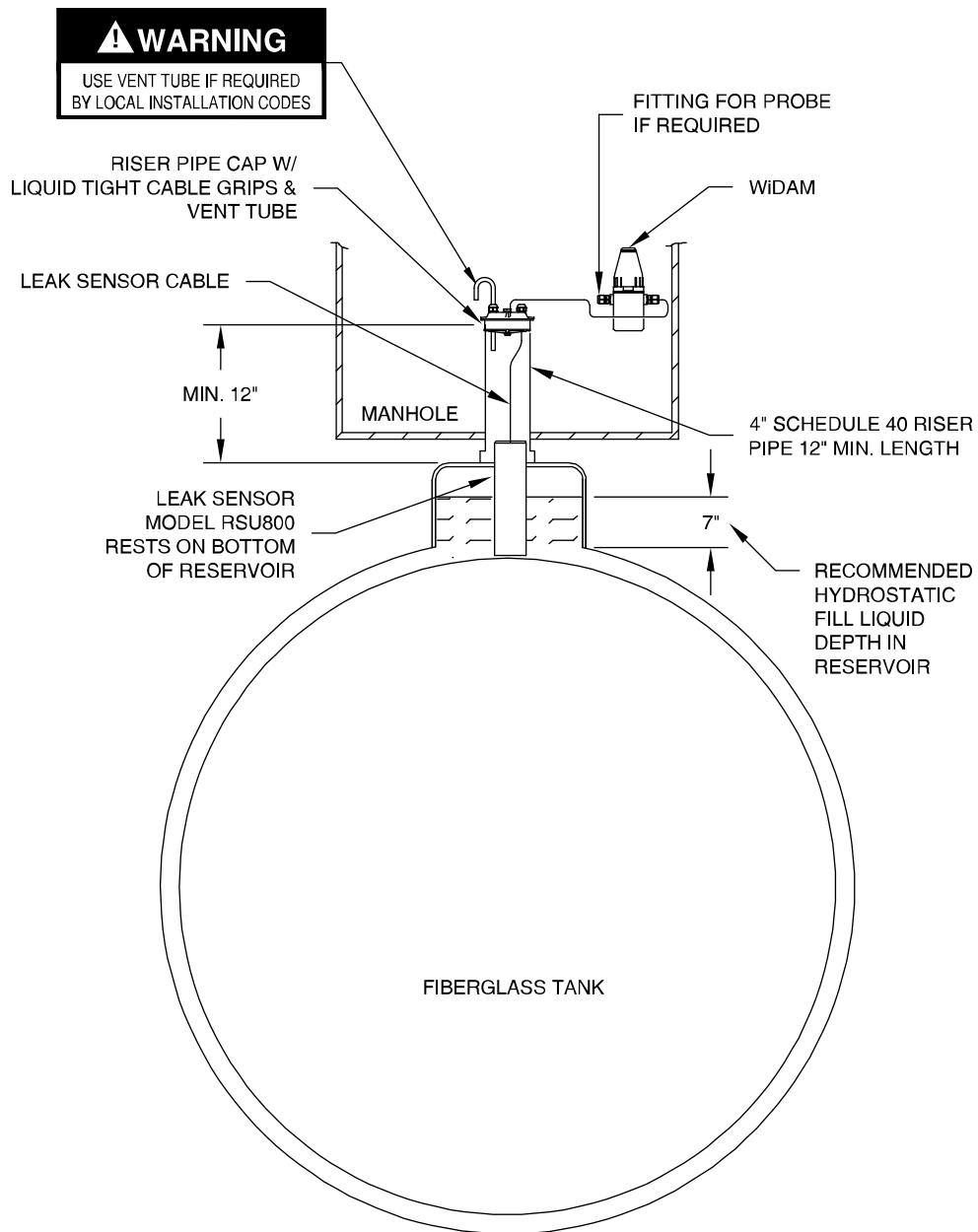

Figure 2-11 - Hydrostatic Leak Sensor Installation in Fiberglass Tanks

**SECTION 3 WIRING INSTALLATION AND DIAGRAMS**

**3.1 TMS2000W POWER WIRING INSTALLATION**

**WIRING DRAWING - TMS2000W AND TMS4000W (Wireless)**

**TMS2000W1 and TMS4000W1 - (See Page 2 for W2)**

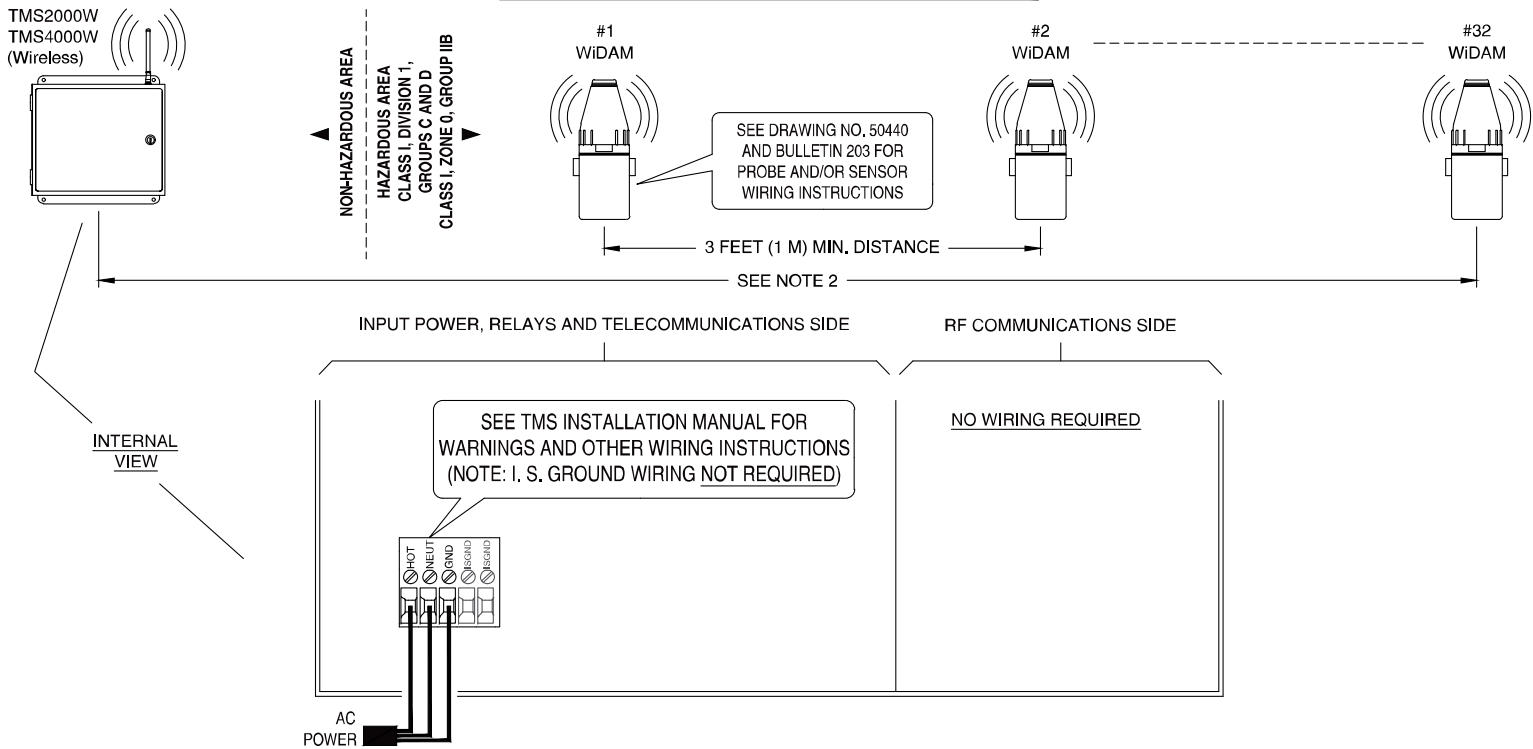

**▲ IMPORTANT NOTES - READ CAREFULLY BEFORE INSTALLATION**

1. CONSOLE MOUNTING: TMS AND MWR200 (IF APPLICABLE) SHOULD NEVER BE LOCATED IN THE HAZARDOUS CLASSIFIED AREA. CAREFUL CONSIDERATION SHOULD BE GIVEN TO LOCATING THE TMS OR MWR200 FOR OPTIMUM RADIO PERFORMANCE.
2. MAXIMUM DISTANCE: IT IS DIFFICULT TO SPECIFY A MAXIMUM TRANSMISSION DISTANCE THAT COVERS ALL APPLICATIONS DUE TO THE VARIABILITY OF INSTALLATIONS. THIS IS ESPECIALLY TRUE OF UST INSTALLATIONS, WHERE MAXIMUM RANGE MAY BE LIMITED TO AS LITTLE AS 100 TO 200 FEET, WHILE AST INSTALLATIONS MAY SEE RANGES UP TO 1000 FEET USING THE STANDARD MONOPOLE ANTENNA, OR UP TO SEVERAL MILES USING A DIRECTIONAL ANTENNA. OTHER FACTORS INCLUDING LINE-OF-SIGHT OBSTACLES AND OTHER RADIO FREQUENCY SOURCES MAY ALSO IMPACT TRANSMISSION DISTANCE.

**Questions? Contact Technical Support at (800) 209-7858**



**Figure 3-1-1 - TMS2000W1 AC Power Wiring**

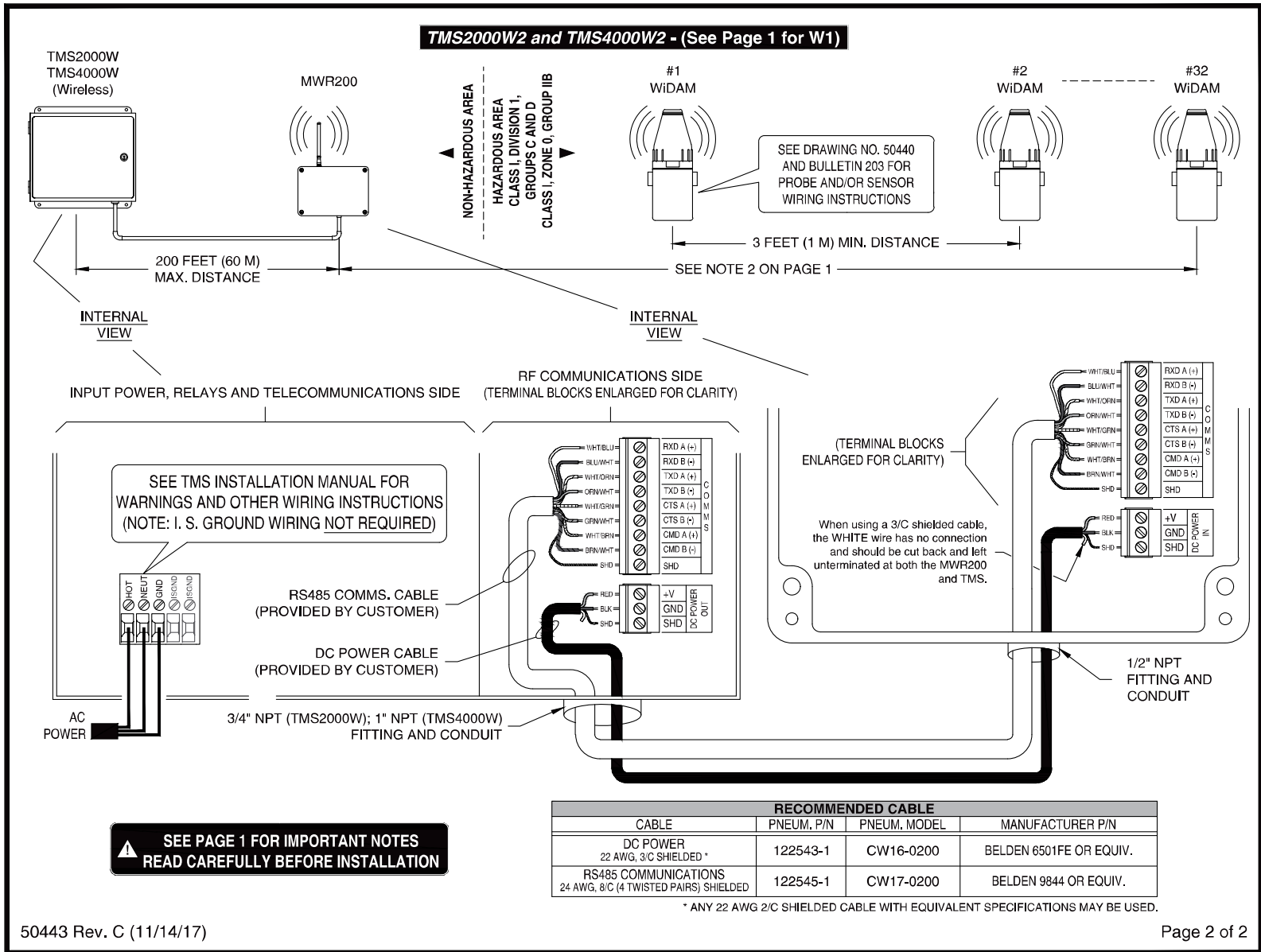

50443 Rev. C (11/14/17)

Page 2 of 2

Figure 3-1-2 – TMS2000W2 AC Power Wiring

### 3.2 TMS2000W CHANNEL SELECTION

The TMS2000W is available in 2 different frequency ranges: 900 MHz (Standard) and 2.4 GHz (Optional). Each system must have a unique channel number selected to avoid conflicts with other wireless Pneumercator equipment. Locations with a single TMS will have both the RF and Sync channels set to the same value. For 900 MHz locations where more than 1 TMS is installed, it is necessary to define one TMS as the synchronization master. This TMS will be the lowest channel number being used and will be responsible for coordinating the RF activity of all Pneumercator equipment on-site. Synchronization is not necessary for 2.4 GHz TMS systems.

#### Setting the Wireless Channel

Wireless Channel	Switch for RF Channel 2	Switch for RF Channel 1	Switch for RF Channel 0
1*	C	C	C
2	C	C	O
3	C	O	C
4	C	O	O
5	O	C	C
6	O	C	O
7	O	O	C
8	O	O	O

#### Setting the Synchronization (Sync) Channel (900 MHz Only)

Sync Channel	Switch for Sync Channel 2	Switch for Sync Channel 1	Switch for Sync Channel 0
1*	C	C	C
2	C	C	O
3	C	O	C
4	C	O	O
5	O	C	C
6	O	C	O
7	O	O	C
8	O	O	O

\* Factory default

**Note:** All WiDAMs must be set to the same Wireless channel as the parent TMS2000W.

**Note:** If there are multiple wireless TMS units at one location, the TMS with the lowest wireless channel number will be the synchronization master. The other TMS unit(s) will sync to the TMS Master.

**Wireless Data Acquisition Module (WiDAM)**  
**PREFERRED WIRING [No external junction box(es)] - See pages 3 and 4 for alternate wiring**

**HAZARDOUS AREA**

CLASS I, DIVISION 1, GROUPS C AND D  
 CLASS I, ZONE 0, GROUP IIB

TYPICAL INSTALLATION OVERVIEW

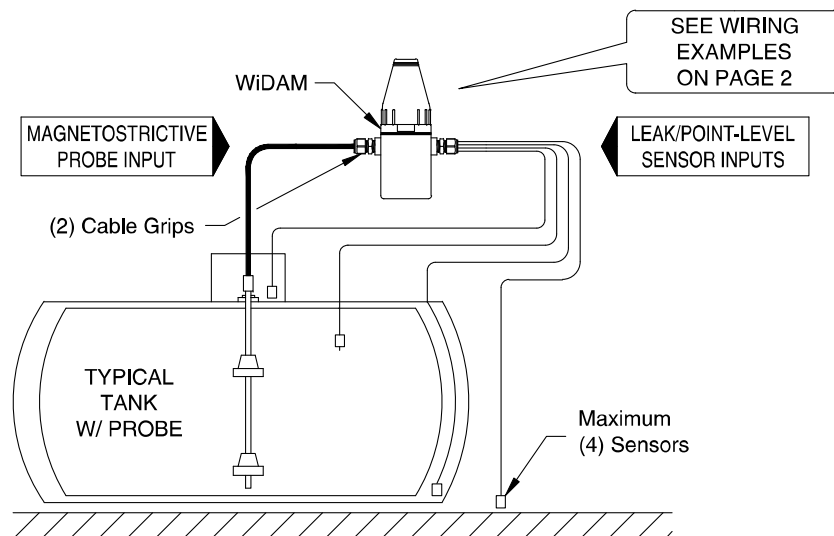

**⚠ IMPORTANT NOTES - READ CAREFULLY BEFORE INSTALLATION**

UNLESS OTHERWISE SPECIFIED:

1. ENTITY PARAMETERS:

Terminals	Vt (V)	It (mA)	Ca (μF)	La (mH)	Po (mW)
TB1 (1, 2, 3, 4, 5)	5.88	256	1000	2.17	412
TB2 (1, 2, 3)	3.96	278	1000	1.84	253
TB2 (4, 5, 6)	3.96	278	1000	1.84	253
TB3 (1, 2, 3)	3.96	278	1000	1.84	253
TB4 (1, 2)	3.96	41	1000	84.6	253

2. PROBE AND SENSOR CABLE LENGTHS SHALL NOT EXCEED 50 FEET (15 METERS). IF CABLE PARAMETERS ARE UNKNOWN THEN THE FOLLOWING SHALL BE USED:  
 Ccable = 60 pF/ft. (197 pF/m.); Lcable = 0.2 μH/ft. (0.657 μH/m.)

FOR EXAMPLE: 1000 ft. X 60 pF/ft. = 0.06 μF  
 100 m X 197 pF/m. = 0.0197 μF

- INSTALLATIONS SHALL COMPLY WITH THE LATEST EDITION OF THE NATIONAL ELECTRICAL CODE (ANSI/NFPA 70) AND THE CANADIAN ELECTRICAL CODE (CEC).
- USE ONLY PNEUMERCATOR BATTERY PACK PART NUMBERS 900621-1-1, 900621-1-2 OR 900621-1-4.
- BATTERY MAY BE REPLACED WITH WIDAM INSTALLED IN THE HAZARDOUS LOCATION.
- COVER MUST BE SECURED SO THAT THE O-RING COMPRESSES TO CREATE A WATERTIGHT SEAL. ALL UNUSED HOLES WITHIN THE CABLE GRIPS MUST REMAIN PLUGGED AND THE COMPRESSION NUT TIGHTENED TO PROVIDE A WATERTIGHT SEAL AT THE CABLE ENTRANCES.
- INPUT WIRING FOR PROBE AND SENSORS MAY BE ROUTED THROUGH THE SAME OPENING IF CABLES CAN BE PROPERLY SEALED WATERTIGHT.



Figure 3-2-1 - Preferred Wiring

Figure 3-2-2 - Preferred Wiring

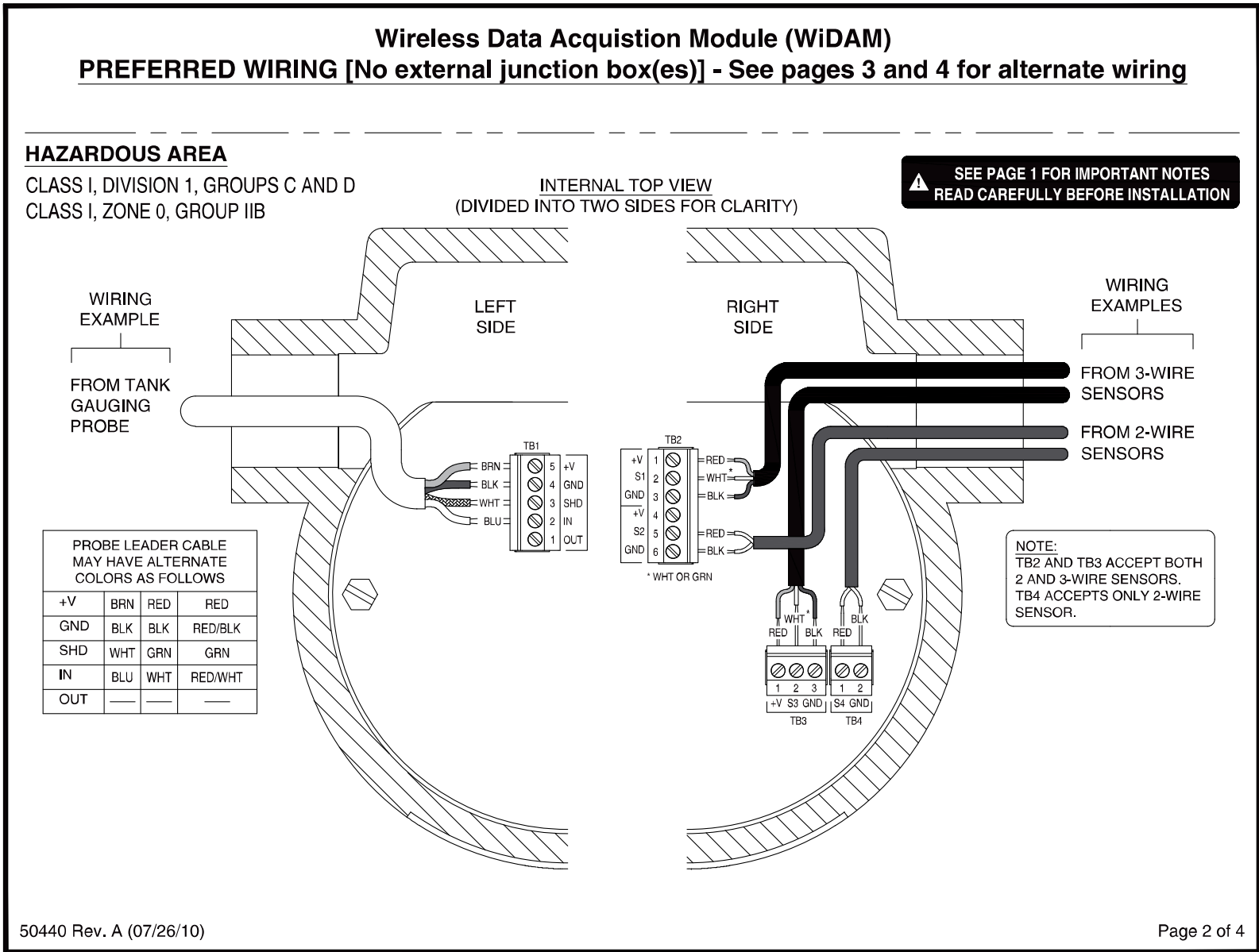

**Wireless Data Acquisition Module (WiDAM)**  
**WIRING w/ EXTERNAL JUNCTION BOX(ES) - See pages 1 and 2 for preferred wiring**

**HAZARDOUS AREA**

CLASS I, DIVISION 1, GROUPS C AND D  
 CLASS I, ZONE 0, GROUP IIB

**SEE PAGE 1 FOR IMPORTANT NOTES  
 READ CAREFULLY BEFORE INSTALLATION**

**TYPICAL INSTALLATION OVERVIEW**

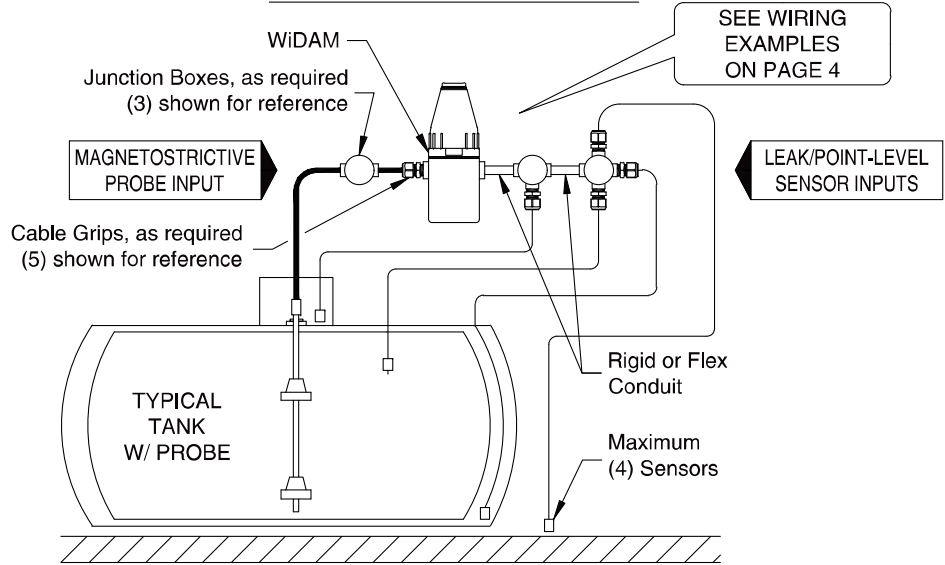

Figure 3-2-3 – Wiring With External Junction Box

## Wireless Data Acquisition Module (WiDAM) WIRING w/ EXTERNAL JUNCTION BOX(ES) - See pages 1 and 2 for preferred wiring

### HAZARDOUS AREA

CLASS I, DIVISION 1, GROUPS C AND D  
CLASS I, ZONE 0, GROUP IIB

**SEE PAGE 1 FOR IMPORTANT NOTES  
READ CAREFULLY BEFORE INSTALLATION**

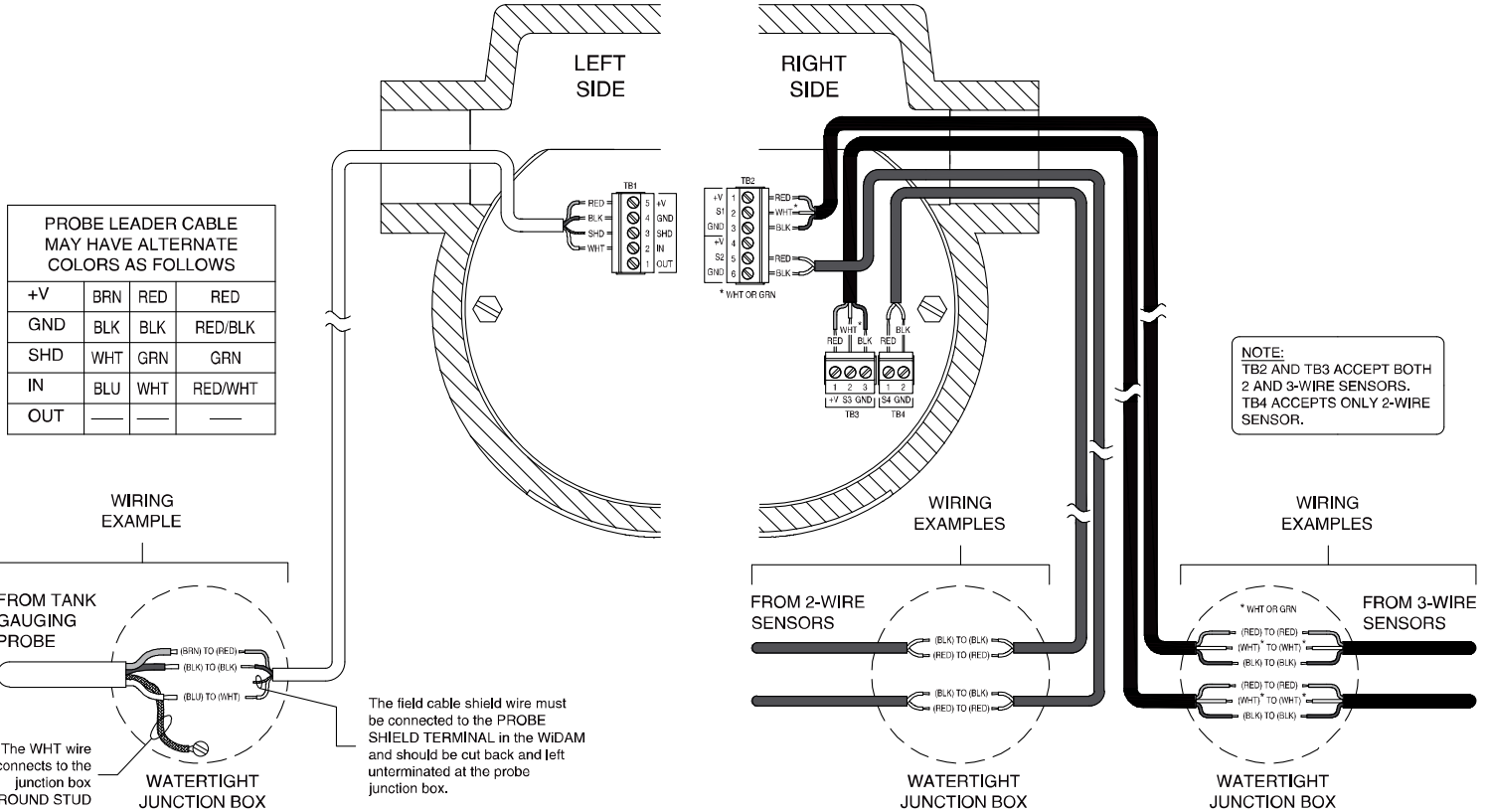

50440 Rev. A (07/26/10)

Page 4 of 4

Figure 3-2-4 Wiring With External Junction Box

3.4 WiDAM CONFIGURATION

**IMPORTANT! WiDAM SWITCH SETTINGS**

**"S1" - RF CHANNEL SETTING**

WiDAM "S1" DIP switch setting should correspond to RF channel ("RF CHAN") setting in the Wireless TMS console.

RF CHANNEL	SWITCH POSITION		
	2	1	0
1	C	C	C
2	C	C	O
3	C	O	C
4	C	O	O
5	O	C	C
6	O	C	O
7	O	O	C
8	O	O	O

WHERE: C = CLOSED, O = OPEN

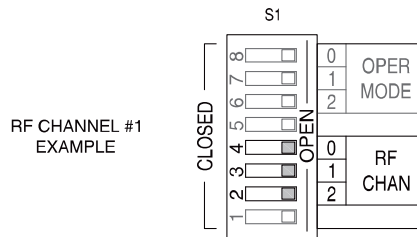

SWITCH CLOSED / OPEN EXAMPLE

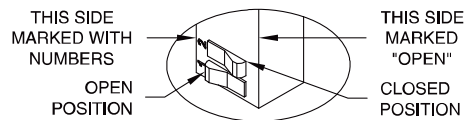

**NOTE:** OPERATIONAL MODE ("OPER MODE") AND UNUSED SWITCHES ARE FACTORY SET CLOSED.

**"S2" AND "S3"- TANK CHANNEL SETTING**

Set WiDAM "S2" and "S3" rotary switches to match enabled tank channel in the Wireless TMS console.

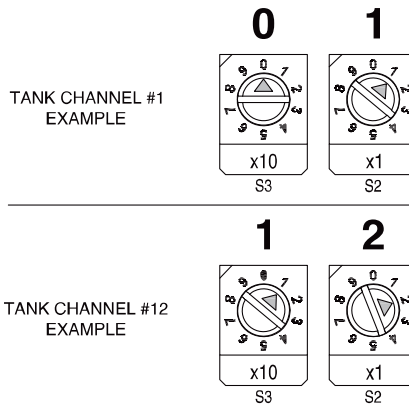

Switch settings will take effect when WiDAM is powered "ON".  
If switches were set when the WiDAM is "ON", turn "OFF" then "ON" again.

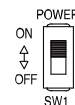

Questions? Contact Technical Support at (800) 209-7858

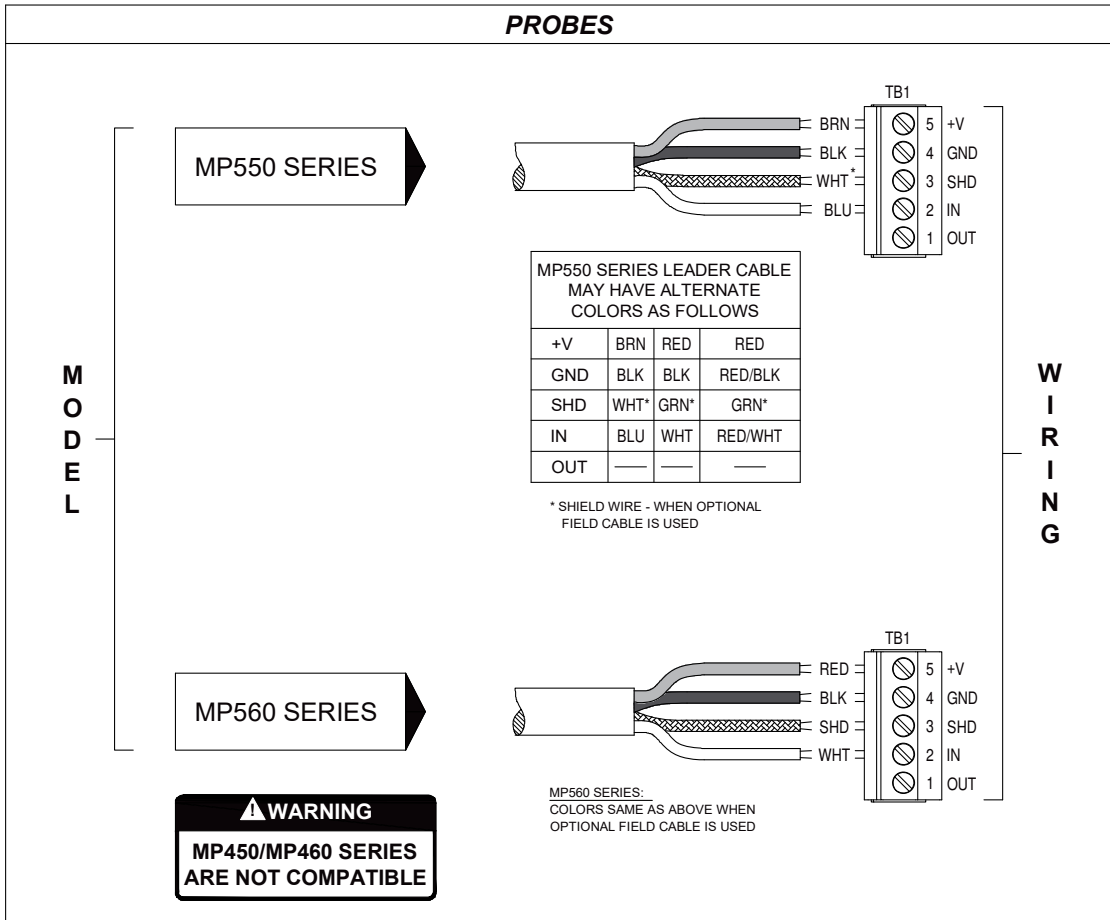

Figure 3-3 Configuration of WiDAM DIP switches

3.5 PROBE/SENSOR WIRING & SPLICES

**IMPORTANT! WiDAM PROBE AND SENSOR WIRING INSTRUCTIONS**

IDENTIFY THE TYPE OF PROBE AND/OR SENSOR(S) TO BE INSTALLED. WIRING MUST BE TERMINATED ON THE TERMINALS INDICATED BELOW TO ENSURE CORRECT OPERATION.



Questions? Contact Technical Support at (800) 209-7858



Figure 3-4-1 - WiDAM probe and sensor wiring

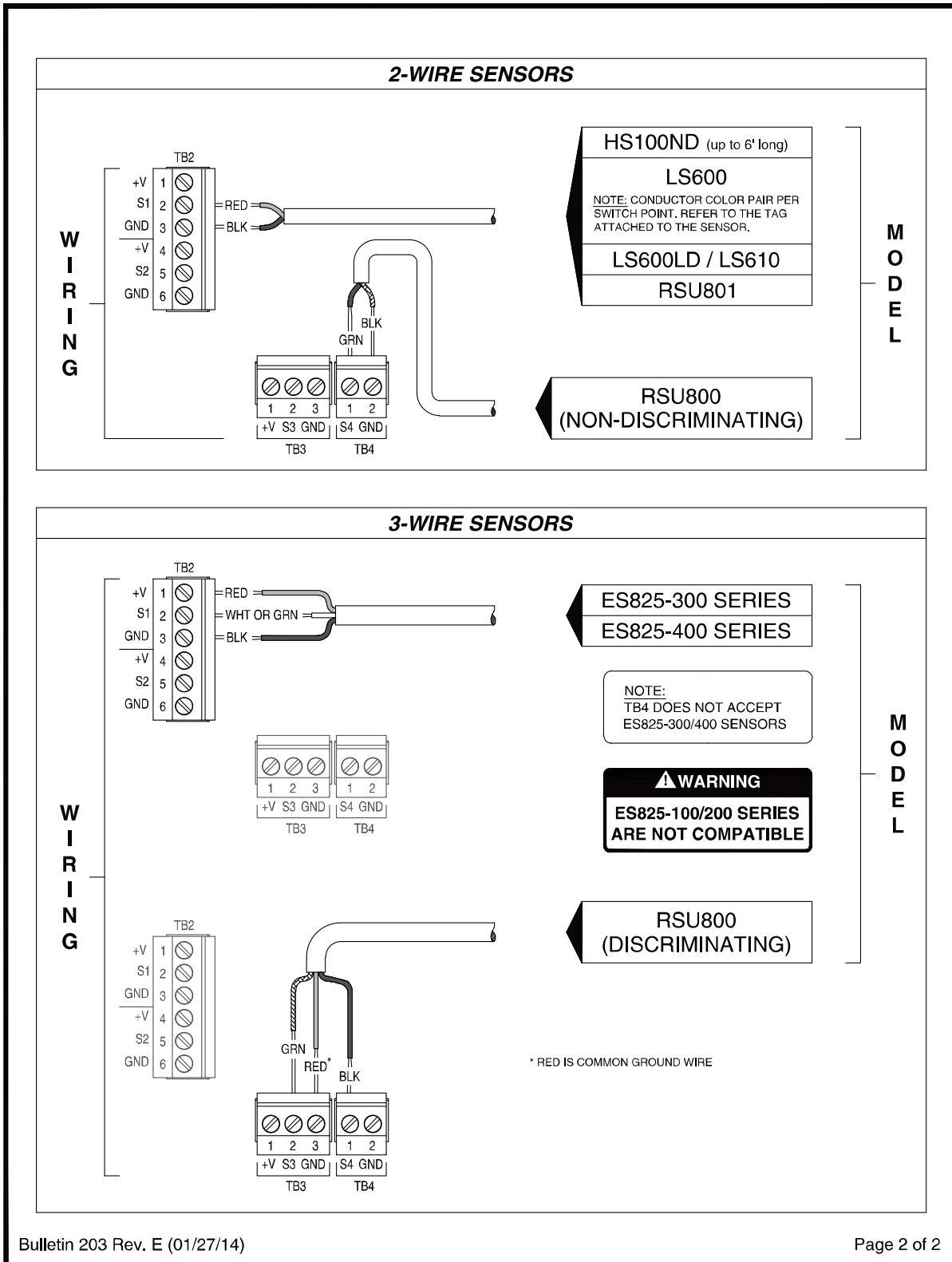
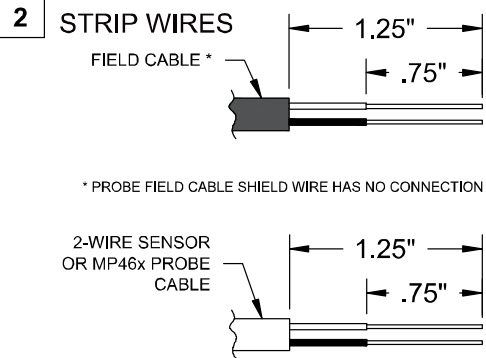
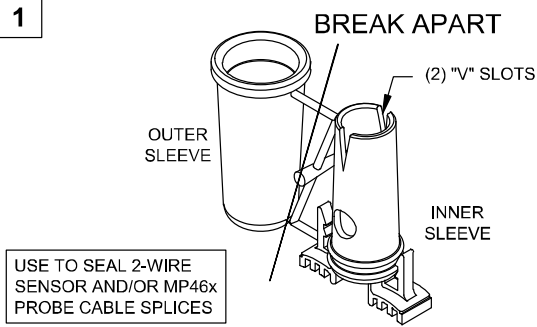

Figure 3-4-2 - WiDAM sensor wiring

**WIRE SPLICE AND SEAL INSTRUCTIONS - 2 CONDUCTOR PAIRS KIT 10585-2**

**WARNING: USE CONNECTORS ONLY FOR THEIR DESIGNATED PURPOSE. DO NOT USE FOR AC WIRING.**



SPLICE SEAL WIRE CONNECTOR PROVIDED BY PNEUMERCATOR

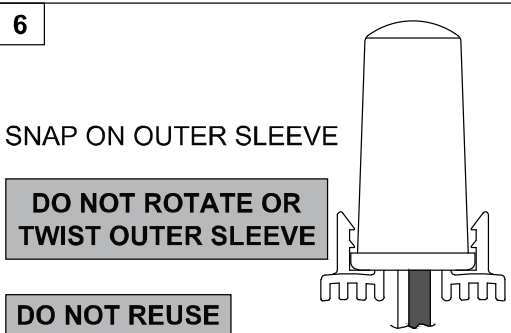
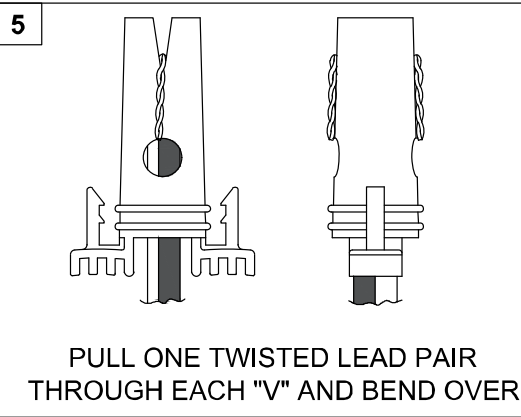
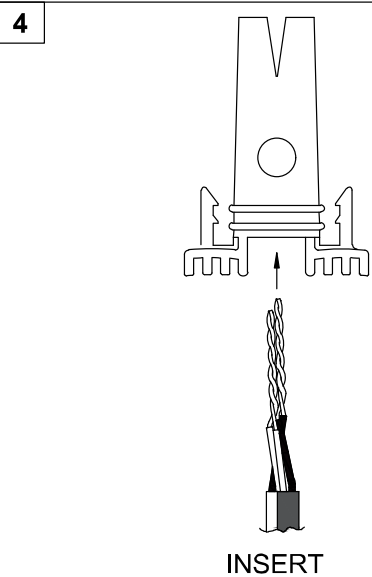
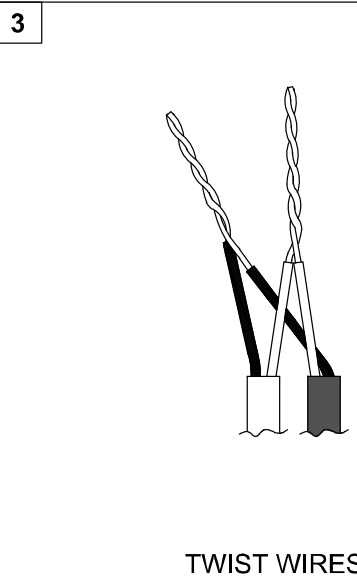

Figure 3-5 – 2-wire sensor Splice Kit Instructions

**WIRE SPLICE AND SEAL INSTRUCTIONS - 3 CONDUCTOR PAIRS KIT 10585-3**

**WARNING: USE CONNECTORS ONLY FOR THEIR DESIGNATED PURPOSE. DO NOT USE FOR AC WIRING.**

<p><b>1</b></p> <p><b>BREAK APART</b></p> <p>USE TO SEAL 3-WIRE SENSOR CABLE SPLICES</p> <p>SPLICE SEAL WIRE CONNECTOR PROVIDED BY PNEUMERCATOR</p>	<p><b>2</b> <b>STRIP WIRES</b></p> <p>FIELD CABLE</p> <p>3-WIRE SENSOR CABLE</p>
---	--

<p><b>3</b></p> <p><b>TWIST WIRES</b></p>	<p><b>4</b></p> <p><b>INSERT</b></p>
---	--------------------------------------

<p><b>5</b></p> <p><b>PULL ONE TWISTED LEAD PAIR THROUGH EACH "V" AND BEND OVER</b></p>	<p><b>6</b></p> <p><b>SNAP ON OUTER SLEEVE</b></p> <p><b>DO NOT ROTATE OR TWIST OUTER SLEEVE</b></p> <p><b>DO NOT REUSE</b></p>
---	---

Figure 3-6 –3-wire Probe/Sensor Splice Kit Instructions

### 3.6 PROGRAMMABLE RELAY OUTPUTS/CONTACT CLOSURE INPUTS

The TMS2000W provides dry contact closure inputs and relay contact closure outputs that are user-programmable via the console front panel or most TMS communications interfaces. Each input is programmable for relay control and alarm functions as well as remote relay acknowledgement or gating functions. Inputs may also be programmed to monitor submersible pump or generator activity. Each relay output is programmable to trigger on any combination of events, including theft, product or water setpoints, leak or point level sensor alarm, contact closure input or system error. Additionally, relays are individually programmable for failsafe mode; delayed shutoff mode and a latching mode for pump up/down functions. Typical relay applications include remote annunciation, pump and siphon break/flow control valve operation, and other user-defined switch closure inputs. These relays also provide a simple and straightforward interface to most programmable logic controllers, building management systems, and similar input monitoring devices.

The standard TMS2000W includes two (2) dry contact closure inputs and two (2) relay outputs as illustrated in Figure 3-7 below. Also shown is an optional 4 Input/4 Relay Output Card. An optional 8 Input/8 Relay Output Card or 16 Relay Output Card is available.

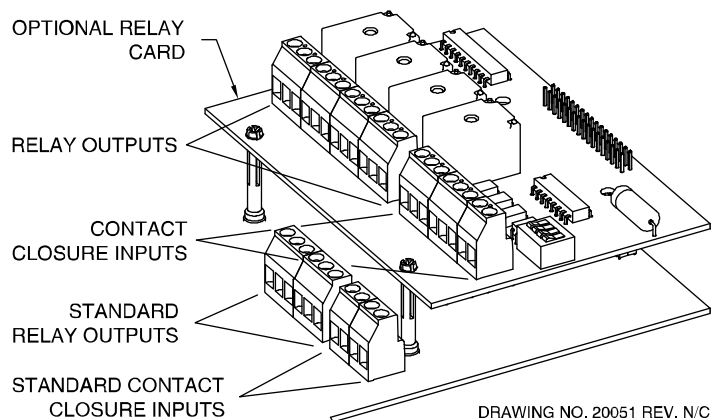

**Figure 3-7 - Relay Output/Contact Closure Input Layout**  
(Optional 4 Relay Output/4 Contact Closure Input Expansion Card shown)

### 3.7 DATA COMMUNICATIONS WIRING

The console's power area is equipped with three (3) communications ports that are assigned as follows:

One (1) for external EIA RS-232 Interface to externally mounted computers or modems.

One (1) for external EIA RS-485 Interface to externally mounted PNEUMERCATOR smart peripheral control devices including the MPX200 wireless peripheral server.

One (1) for use with an optional communications expansion board.

Figure 3-8 shows the locations of these ports.

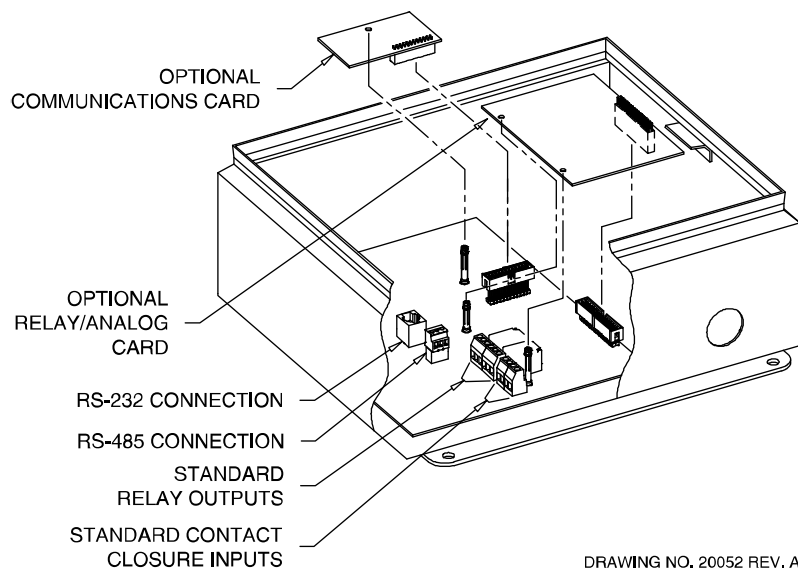

Figure 3-8 - Non-Hazardous Expansion Option Installation





# ***PNEUMERCATOR TMS SERIES***

## LIMITED WARRANTY

<b>TMS Series</b>
-------------------

**Pneumercator**, here and after referred to as **PCO**, warrants its **TMS Series** family of products to be free of defects in material and workmanship for a period of **Twelve (12) months** from date of installation or **Fifteen (15) months** from date of invoice, whichever comes first.

During the warranty period on the **TMS Series**, **PCO**, or factory third party independent representatives will repair or replace the product at the location where it is installed at no additional cost to the customer.

Packages must be inspected upon receipt for damage, missing parts, and/or manuals. **PCO** must be contacted by telephone immediately with a description of damaged or missing parts so replacements can be sent. Written details must be sent within **thirty (30) days**.

Pneumercator will not be responsible for shipping charges incurred by the customer.

Warranty repair coverage invoices will be paid if **all** the following conditions are met:

- PCO has acknowledged and authorized warranty work to be done by issuing a *Warranty Repair Number*.
- Start-up Service technician has been trained by PCO
- Warranty start-up form has been submitted to PCO
- Technician fills out and submits a PCO "Service Report"
- Parts (if any) used are returned to PCO with a proper WRGA (*Warranty Return Goods Authorization*)
- Returned parts are found to be defective.

Repair time will be paid according to PCO document "Standard Warranty Labor Charge Schedule"

If the Warranty Registration/Start up Check List has been completed and returned on file with the factory and the product is installed in accordance with the specific PCO Installation Product Manual, PCO will activate and meet warranty criteria as described above. Warranty criteria shall be voided if any product has been subjected to misuse, negligence, damage from acts of nature (lightning, wind, rain, etc.) or is in violation of the products design intent, disregard to warnings, instructions, modified or repaired by unauthorized personnel or improperly installed. Given that the third party independent contractor has installed the equipment in accordance with the specific product instruction manual, and followed all precautions, PCO will fulfill the terms stated in our warranty obligation.

Under no circumstances does the warranty provide a remedy in excess of the equipment. No other expressed or implied warranty is given by PCO. PCO shall not be liable for consequential damages or any expenses incurred by the user.

Distributed by:

 **PNEUMERCATOR**  
1785 Expressway Drive North, Hauppauge NY 11788  
(631) 293-8450 Fax (631) 293-8533

--