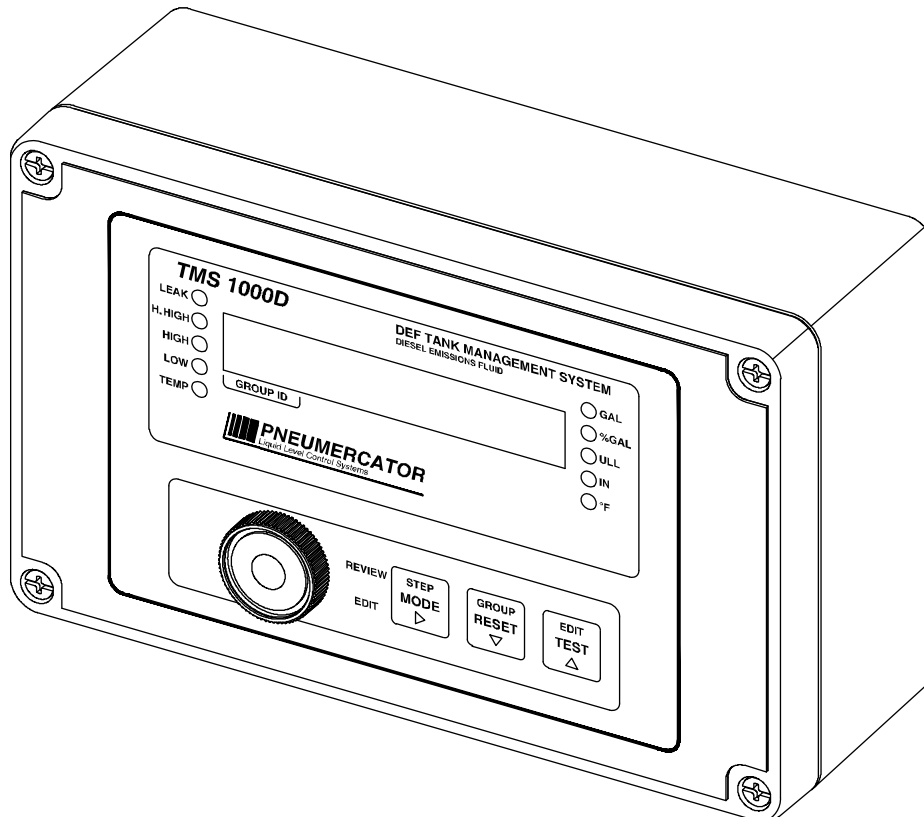


# INSTALLATION MANUAL



DRAWING NO. 20156 REV. N/C

## **MODEL TMS1000D**

**© COPYRIGHT 2018 PNEUMERCATOR CO., INC.  
1785 EXPRESSWAY DRIVE NORTH  
HAUPPAUGE, NY 11788**

TEL: (631) 293-8450  
FAX: (631) 293-8533  
<http://www.pneumercator.com>



Note: A separate OPERATING MANUAL is available, but NOT required for TMS1000D installation.

TABLE OF CONTENTS
-------------------

	Page
SAFETY INFORMATION .....	4
Section 1 PRODUCT DESCRIPTION	
1.1 General System Overview .....	5
1.2 Control Console .....	6
1.3 Liquid Level Probes .....	8
1.4 Liquid Leak Sensors .....	9
Section 2 INSTALLATION DETAILS	
2.1 Installation Checklist .....	11
2.2 Control Console Installation .....	12
2.3 Level Probe Installation .....	16
2.4 Leak Sensor Installation – Steel Tanks .....	18
2.5 Leak Sensor Installation – Piping Sumps and Dispenser Pans, Vaulted Tank.....	19
2.6 Leak Sensor Installation – Fiberglass Underground Tanks .....	20
2.7 Leak Sensor Installation – Fiberglass Underground Tank Reservoirs .....	21
Section 3 WIRING INSTALLATION AND DIAGRAMS	
3.1 System Probe/Sensor Wiring .....	23
3.2 Power Wiring .....	27
3.3 Probe/Sensor Wiring & Splices .....	28
3.4 Programmable Relay Outputs/Contact Closure Inputs .....	30
3.5 Data Communications Wiring.....	31
3.6 Probe Map/System Setup .....	32

**⚠ IMPORTANT SAFETY INFORMATION**

**This manual contains instructions for installing electrical hardware in hazard areas.**

**The following warnings must be considered to be in compliance with accepted codes.**

**Any inquiries about this manual, or to return defective equipment should be directed to:**

**PNEUMERCATOR COMPANY  
1785 EXPRESSWAY DRIVE NORTH  
HAUPPAUGE, NY 11788  
Attention: Technical Services  
TEL: (631) 293-8450  
FAX: (631) 293-8533  
TOLL FREE: (800) 209-7858  
[www.pneumercator.com](http://www.pneumercator.com)**

**⚠ WARNING**

**Installation must be in strict accordance with this manual as adopted from the following codes:**

- NFPA 70, "National Electric Code."**
- NFPA 30A, "Automotive and Marine Service Station Code."**

**FAILURE TO COMPLY MAY RESULT IN PERSONAL INJURY, PROPERTY LOSS AND EQUIPMENT DAMAGE.**

**⚠ WARNING**

**Alteration, modification or replacement with non-factory components could impair the operation of this equipment, and void the warranty.**

**FAILURE TO COMPLY MAY RESULT IN PERSONAL INJURY, PROPERTY LOSS AND EQUIPMENT DAMAGE.**

## SECTION 1 – PRODUCT DESCRIPTIONS

### 1.1 GENERAL SYSTEM OVERVIEW

The TMS1000D is a fully integrated tank monitor system that combines level measurement with leak detection using external sensors for secondary containment. Figure 1-1 shows a typical block diagram of how a system should be configured for installation. This diagram is not a detailed wiring diagram, which is found in Section 3 of this manual. Figure 1-1 is to guide the installer in planning the actual installation, and give a general overview of the TANK, LEVEL PROBE, EXTERNAL SENSORS, and OPTIONAL equipment that may be required for a typical installation. Figure 1-1 shows one (1) tank with two (2) sensors. Refer to the specific design drawing for the customer's actual site for complete site-specific details on how many sensors are specified.

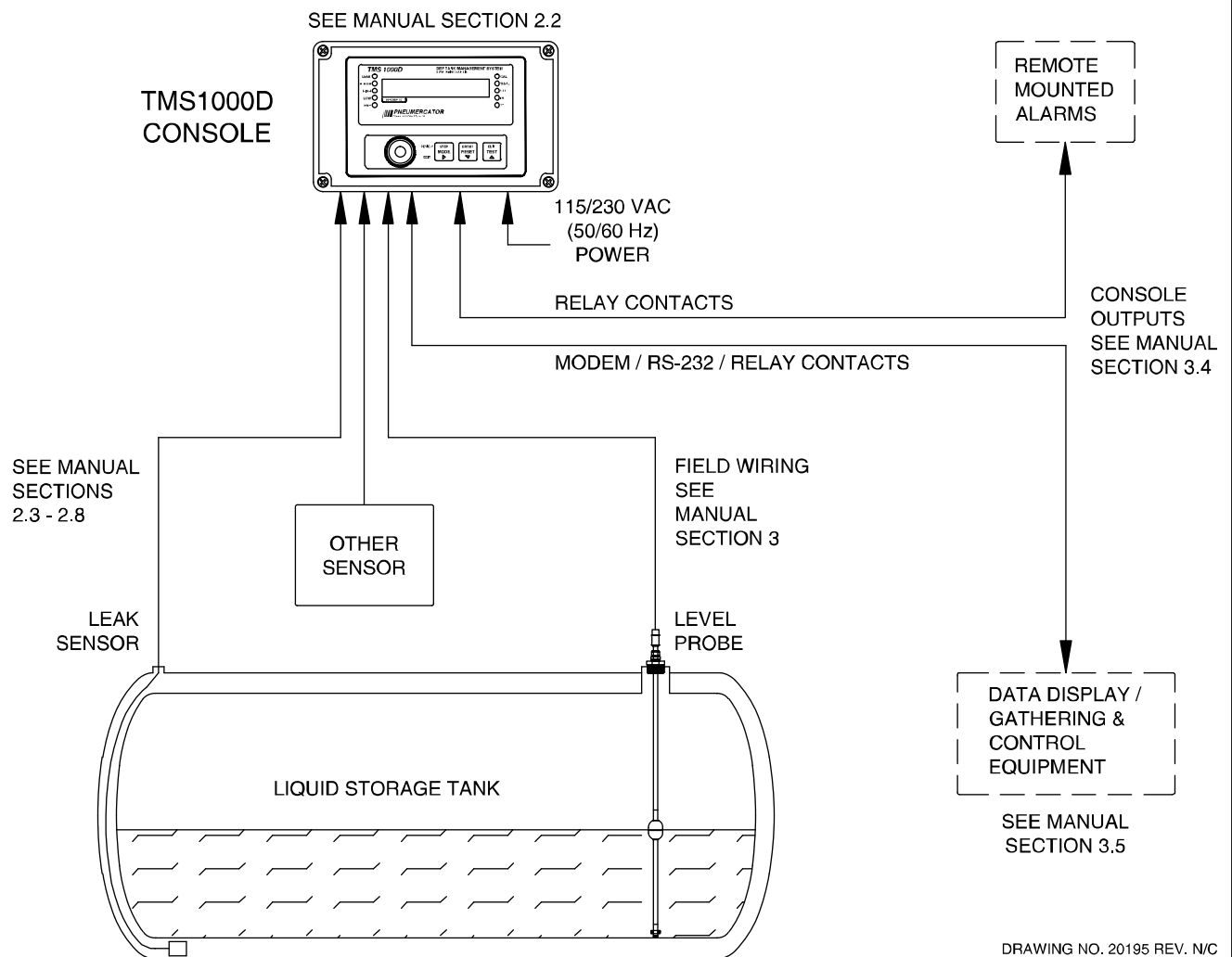


Figure 1-1 – Typical System Block Diagram

**1.2 CONTROL CONSOLE DESCRIPTION**

All standard configurations are equipped with 1 mag. probe/2 leak sensor inputs, 1 RS-232 serial port, 4 Fully programmable Relay outputs/2 Dry contact inputs, NEMA 4X enclosure.

**⚠ WARNING**

**Installation MUST be done by qualified personnel familiar with local wiring codes and electrical safety practices. FAILURE TO COMPLY MAY RESULT IN PERSONAL INJURY, PROPERTY LOSS AND EQUIPMENT DAMAGE.**

See Figure 1-2 below for overview.

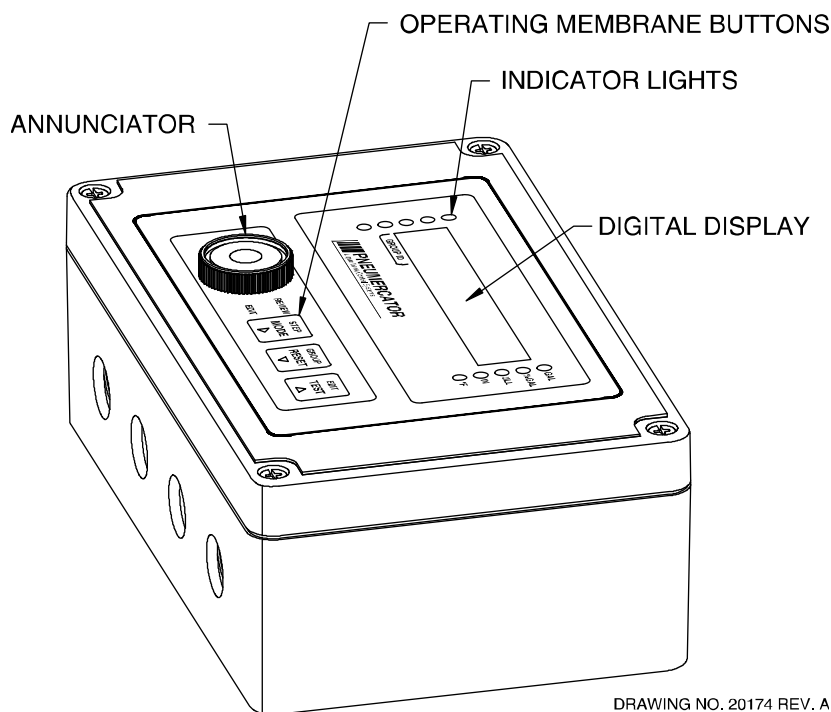


Figure 1-2 – TMS1000D Console Outline

**⚠ WARNING**

**The console is designed for Ordinary Location, Non-Hazardous installation only, as defined by the National Electrical Code (NEC). DO NOT install where flammable vapors may be present. FAILURE TO COMPLY MAY RESULT IN PERSONAL INJURY, PROPERTY LOSS AND EQUIPMENT DAMAGE.**

The console should be located in an area that is easily accessible to the personnel responsible for operation and maintenance of the system. Metal conduiting is recommended and may be required by local codes. All outdoor conduits must be watertight.

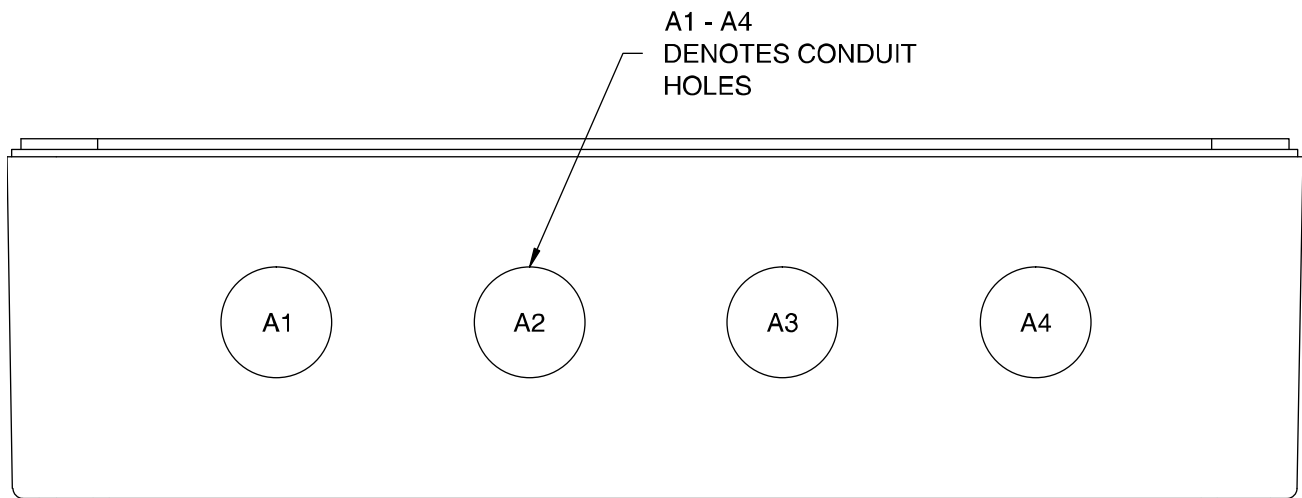
All conduit entries are provided on the bottom of the enclosure. If a conduit entry is not being used, it must be sealed with an appropriate plug.

## ⚠ WARNING

**Do not drill or modify enclosure. Use only conduit entries provided. FAILURE TO COMPLY WILL VOID WARRANTY AND MAY PRESENT A SAFETY HAZARD RESULTING IN PERSONAL INJURY, PROPERTY LOSS AND EQUIPMENT DAMAGE.**

## ⚠ WARNING

**Conduit entries must only be used for their designated purpose in order to assure safe operation and to maintain safety certification. FAILURE TO COMPLY WILL VOID WARRANTY AND MAY PRESENT A SAFETY HAZARD RESULTING IN PERSONAL INJURY, PROPERTY LOSS AND EQUIPMENT DAMAGE.**



1/2" NPT OR EQUIVALENT CONDUIT SIZE  
 A1 = PROBE INPUT / (2) SENSOR INPUTS  
 A2 = COMMUNICATIONS CABLES  
 A3 = RELAY INPUTS / OUTPUTS  
 A4 = POWER

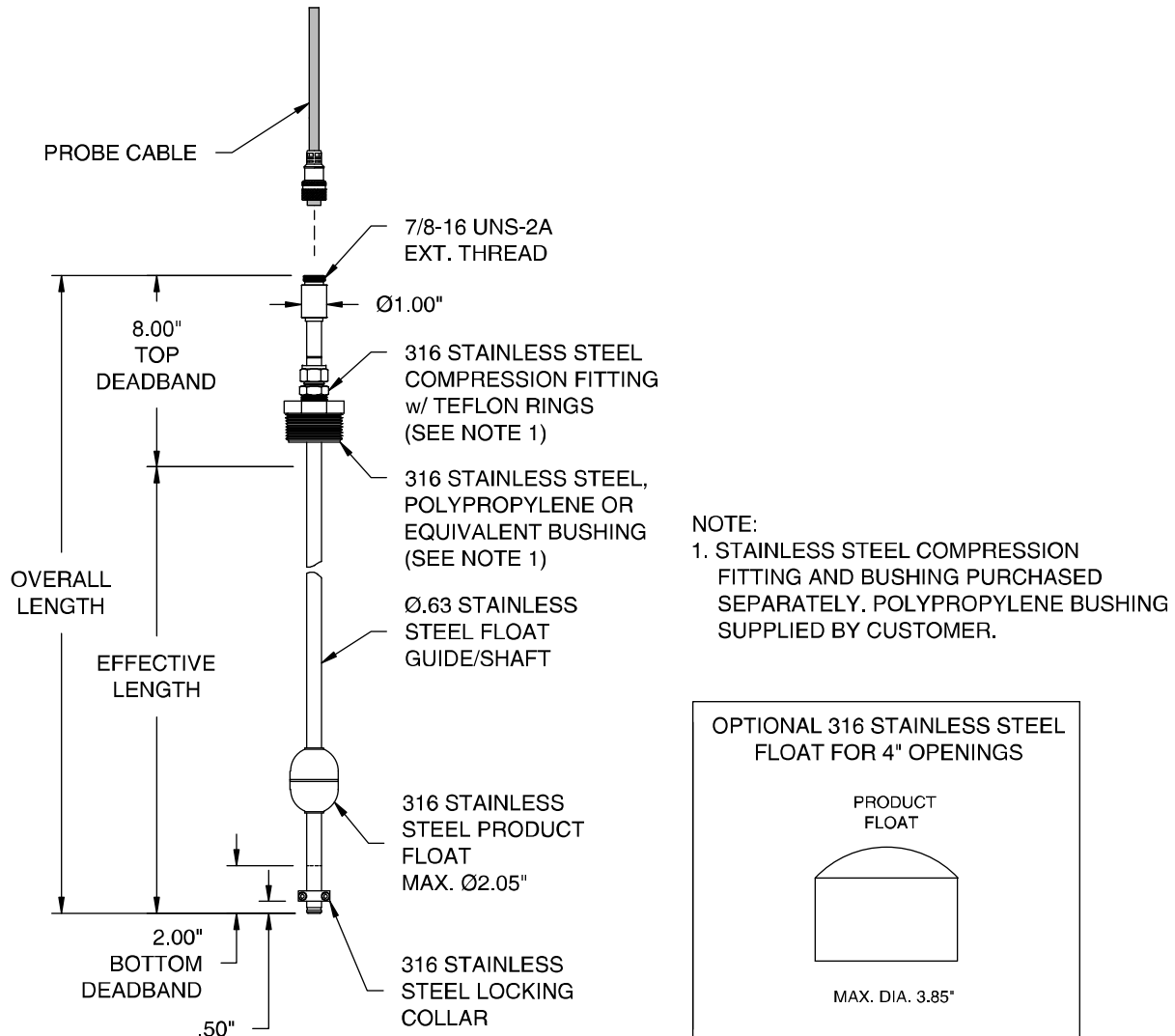
DRAWING NO. 20176 REV. A

Figure 1-3 – TMS1000D Designated Conduit Locations

**1.3 LIQUID LEVEL PROBE DESCRIPTION**

TMS1000D should be ordered with the MP550S magnetostrictive level probe. This probe will provide inventory management on tanks up to 15’.

Figure 1-4 shows the standard MP550S probe with dimensions and specifications. Note the standard probe requires a 2-inch female NPT tank fitting, and is supplied with a 6-foot cable; it does not include the MOUNTING HARDWARE, which must be ordered separately. Before installing, verify the model number matches the tank size intended, and that any accessories are available on site.



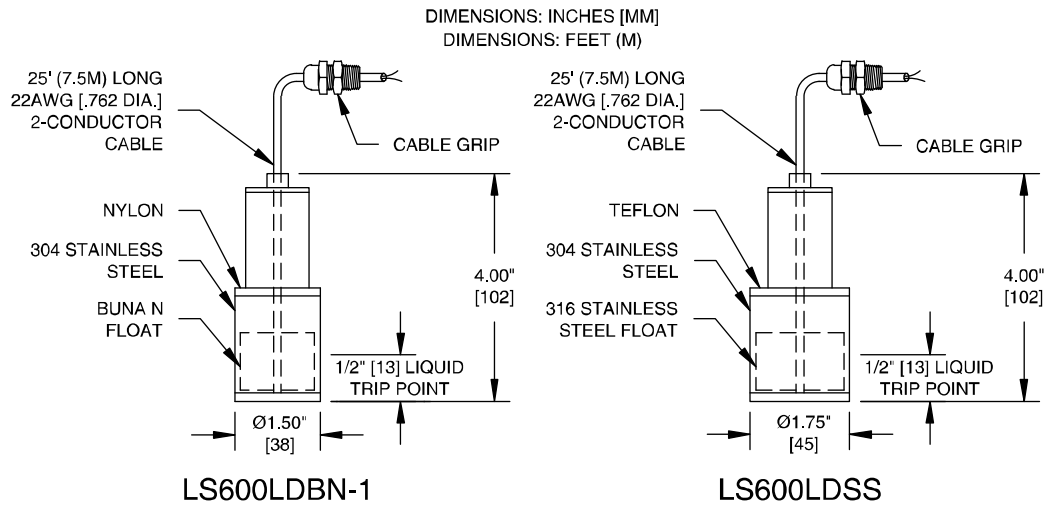
DRAWING NO. 20168 REV. N/C

**Figure 1-4 – Liquid Level Probe Outline**

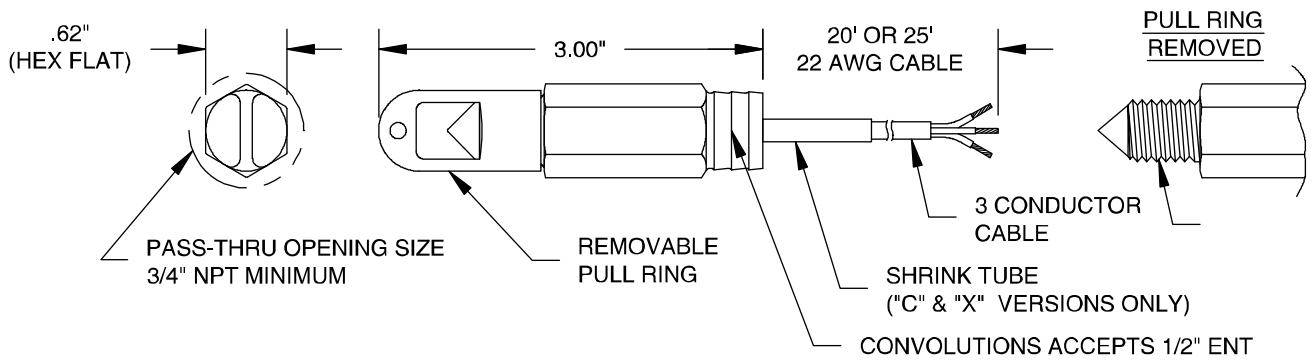


**1.4 LIQUID LEAK SENSOR DESCRIPTION**

TMS1000D can be integrated with a variety of liquid sensors used for monitoring secondary containment areas around tanks and pipes. The maximum is 2 sensors depending on the overall job configuration; check the specific job design drawings for the actual number and type specified. Figures 1-5 through 1-8 show four (4) typical sensor types provided by Pneumercator with their most typical applications. Other non-Pneumercator models may be used; however, their use with TMS1000D should have been approved before attempting to wire them into the system.

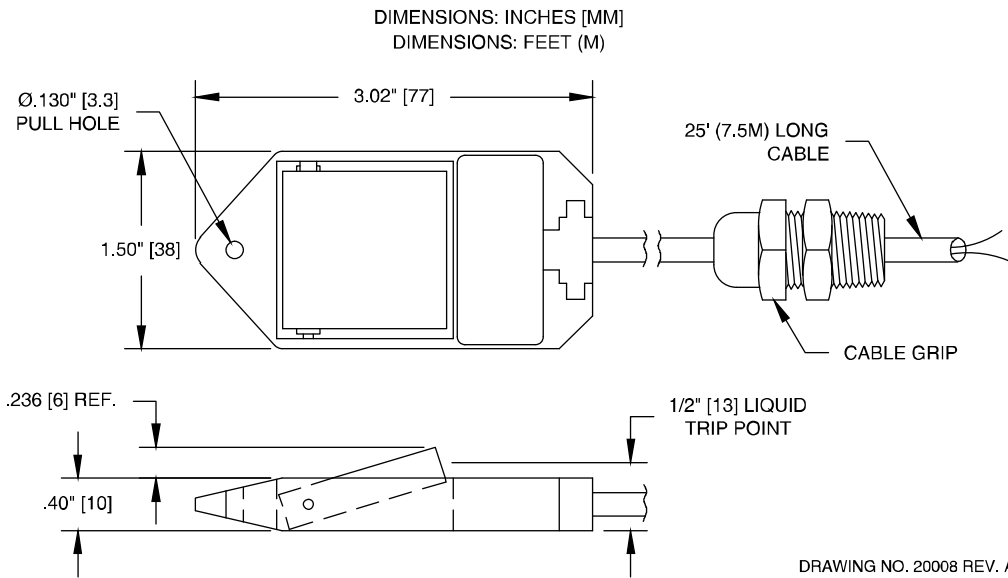


**Figure 1-5 – LS600 LD Series**

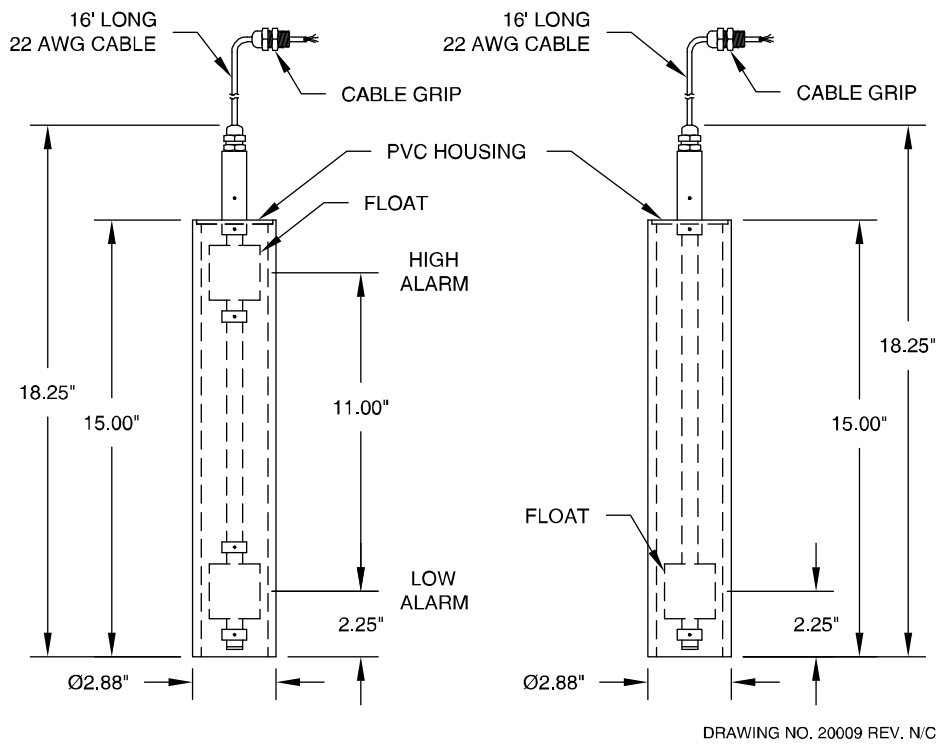


DRAWING NO. 20173 REV. N/C

**Figure 1-6 – ES825-300FL**



**Figure 1-7 – LS610**



**Figure 1-8 – RSU800**

## SECTION 2 – INSTALLATION DETAILS

### 2.1 INSTALLATION CHECKLIST

#### **⚠ WARNING**

**Do NOT apply power to the TMS1000D until its installation has been checked and found to be in accordance with these instructions; National Electric Code; Federal, State and Local codes; and other applicable safety codes. FAILURE TO COMPLY MAY RESULT IN PERSONAL INJURY, PROPERTY LOSS AND EQUIPMENT DAMAGE.**

The following points should be reviewed in preparation for installation, and again when installation is complete.

1. Review Figure 3-3 to ensure that all of the safety/wiring requirements have been met.
2. Check that all equipment at job site matches the DESIGN DRAWING SPECIFICATIONS for the tank sizes and control features required.
3. **The console should never be mounted inside a hazardous area.**
4. POWER to the console should be properly wired to a DEDICATED 120/240 VAC CIRCUIT BREAKER. No other equipment can be powered from the same circuit breaker as the TMS.
5. System cannot be connected to equipment that uses or generates more than 250 volts with respect to earth.
6. All TMS grounds must be terminated at the GND BUSS BAR in the same service panel as TMS power. A grounding rod, coldwater pipe or other connection should not be used. Refer to Figure 3-2 for illustrated details.
7. The magnetostrictive probe input and the sensor inputs are two different circuits and must be installed in separate cables or in one cable which has suitable insulation. Refer to NEC Article 504-30 (b) or CEC Appendix F6.3 for additional information.
8. **Do not drill or modify enclosure.** Use only conduit entries provided. Failure to comply will void warranty and may present a safety hazard.
9. Probe/sensor cabling should be factory approved or electrical equivalents. Color-coding or numbering is highly recommended.
10. WATERPROOFING FIELD WIRE SPLICES using factory supplied splice kits is required for proper system operation.

## 2.2 CONTROL CONSOLE INSTALLATION

The TMS1000D is designed for both indoor and outdoor installation. If the unit is to be installed outdoors, the installer must pay attention to local code requirements for outdoor conduit runs containing AC line voltage.

**WARNING! This device is designed for Ordinary Location, Non-Hazardous installation only, as defined by Underwriters Laboratories (UL) and the National Electrical Code (NEC). DO NOT install where flammable vapors may be present.**

### 2.2.1 MOUNTING

The TMS1000D is designed for wall mounting using the four mounting holes as shown in Figure 2-1. Mounting hole placement is made easy using supplied 1:1 scale mounting template in Figure 2-2. Note that these mounting holes are outside of the gasketed interior of the enclosure and therefore do not affect weatherproof performance.

DIMENSIONS: INCHES [MM]

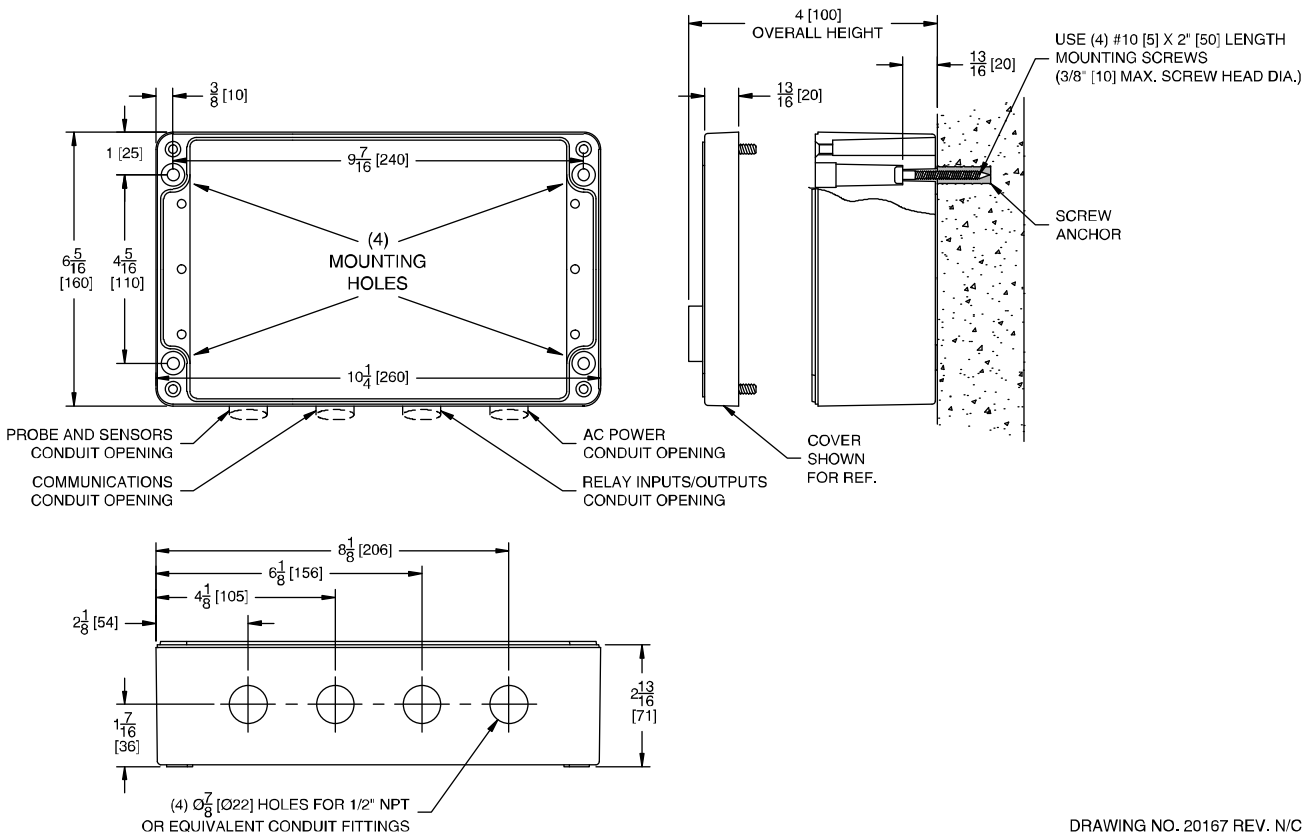
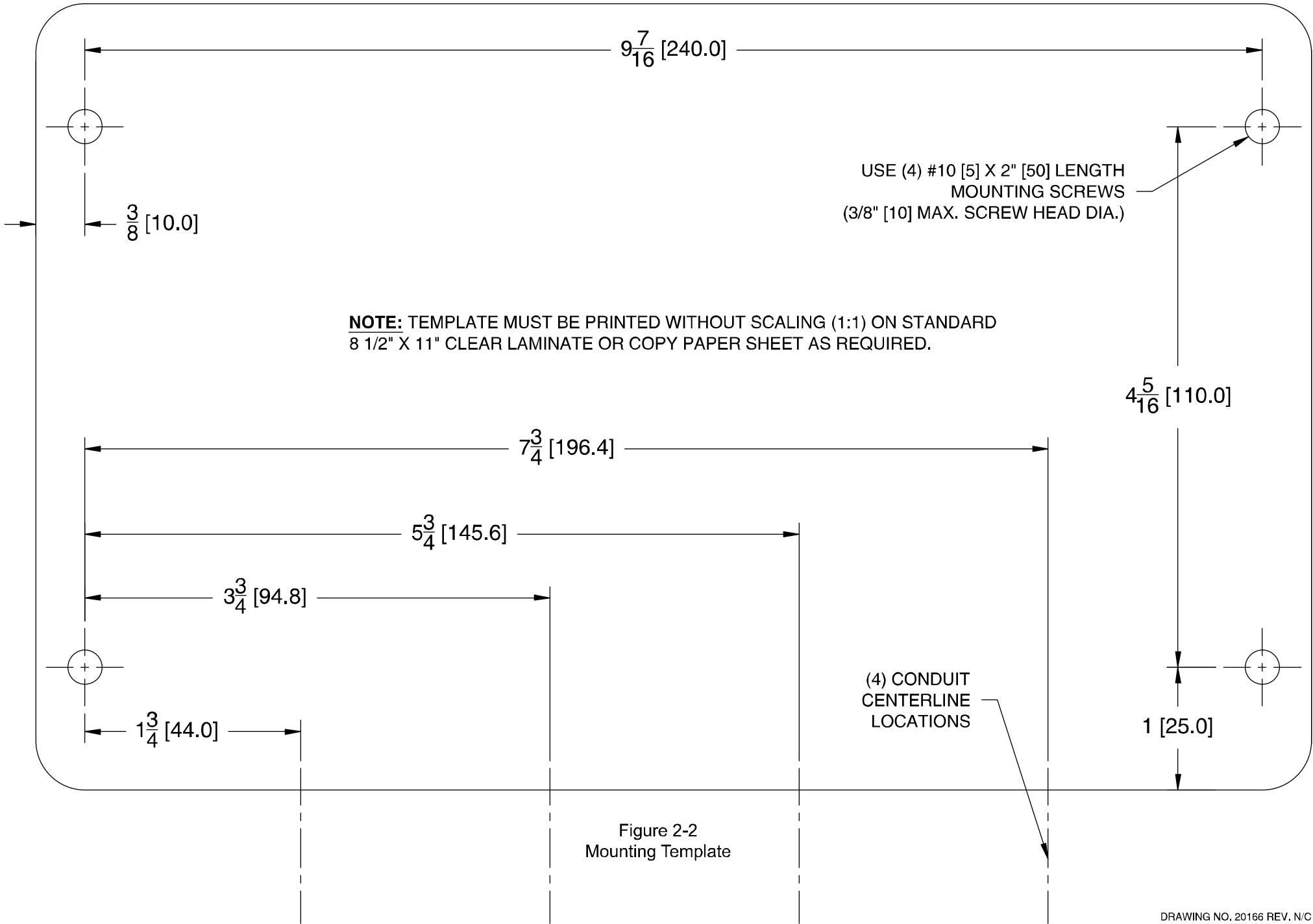


Figure 2-1 – Mounting Dimensions

# TMS1000 MOUNTING AND CONDUIT LOCATION TEMPLATE

DIMENSIONS: INCHES [MM]

SCALE 1:1





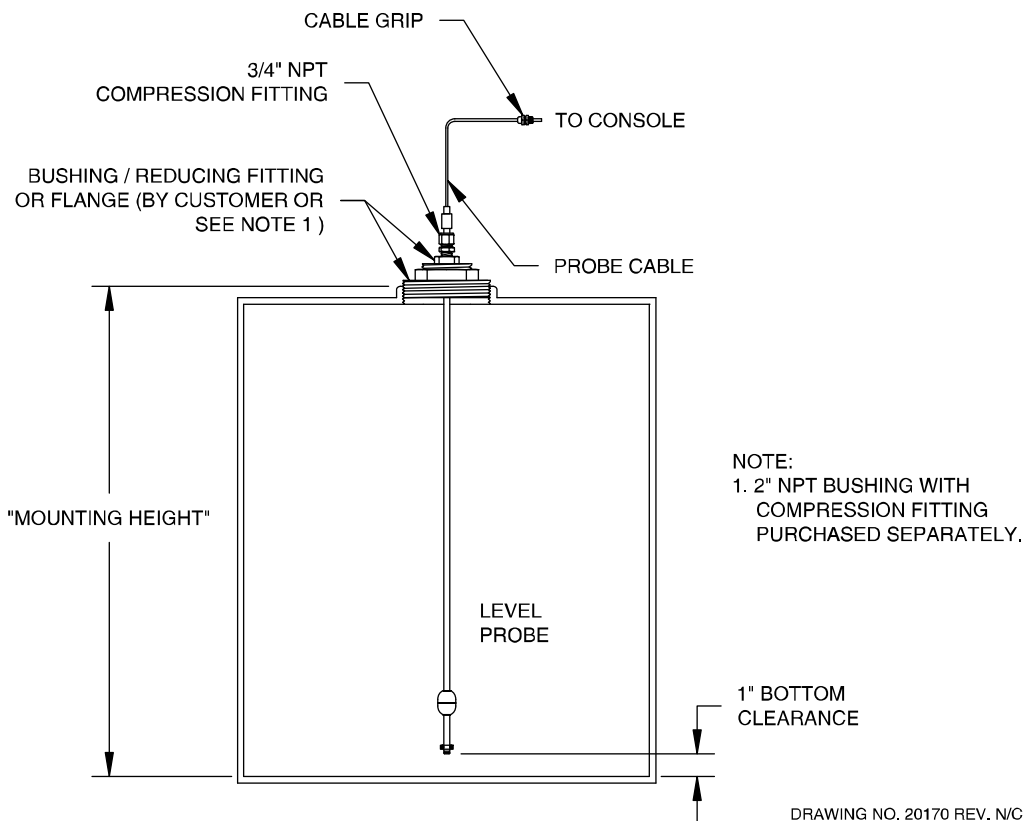


### 2.3 BUSHING OR FLANGE MOUNT METHOD FOR ALL TANKS

This method is recommended for DEF tanks with standard 2, 3 and 4-inch openings. The level probe will "hang" inside the tank at a fixed position supported by the tank-mounting fitting. This will protect the purity of the DEF by reducing the number of wetted materials.

Because the probe is fixed to the mounting fitting, it is critical during installation to allow a 1-INCH BOTTOM CLEARANCE between the probe's FOOT REST and tank bottom or strike plate. This will prevent the probe touching the tank bottom during tank expansion and contraction. The 1-inch clearance dimension is standard and has been properly accounted for in the probe's manufacture.

The customer must supply an appropriate mounting fitting to mate with the tank opening, if less than 2 inches, to accommodate the PK2-DM3 Direct Mount Probe Kit. Assembly is as illustrated in Figure 2-5.



**Figure 2-4 - Reducer Fitting or Flange Mounting for Aboveground Tanks**

Install the level probe per Figure 2-4 as follows:

1. Select the correct probe for the tank. Match the model number with the tank internal dimensions per Figure 1-4.
2. Remove the probe from its shipping container. Remove all packing material.
3. Slowly lower the probe into tank opening. The probe should be vertical with its electronic housing totally visible above the tank fitting. When the probe touches the bottom, screw the bushing into the tank. DO NOT tighten the compression fitting at this time. Mark the shaft and lift the probe up 1 INCH.



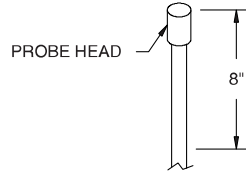
**ASSEMBLY INSTRUCTIONS - MP550S DIRECT MOUNTED MODEL**

**Diesel Emissions Fluid (DEF)**

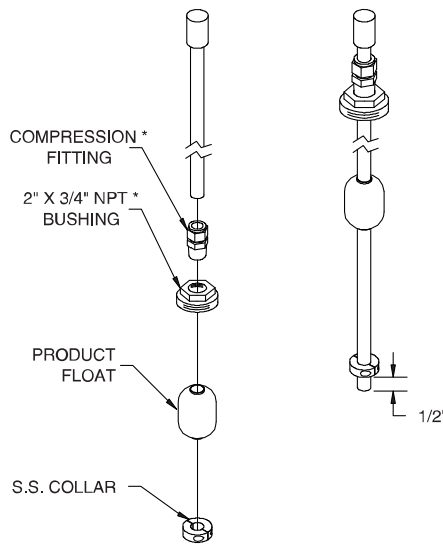
**Questions? Contact Technical Support at (800) 209-7858**

*FOR INSTALLATION AND WIRING SEE TMS MANUAL*

- 1** The top of the probe is an ungageable deadband. Verify that the probe is of sufficient length so that the float's magnet will not travel into this deadband.



**2 2" DIRECT MOUNTING ASSEMBLY**



\* PURCHASED SEPARATELY FROM PNEUMERCATOR AS MODEL NO. PK2-DMx.



**Figure 2-5 – MP55xS Probe Assembly Instructions - Direct Mount**

4. Tighten the cable connector on top of the probe housing to ensure a **WATERTIGHT SEAL**.
5. Route the probe cable to the junction box and complete the wiring installation in accordance with Section 3

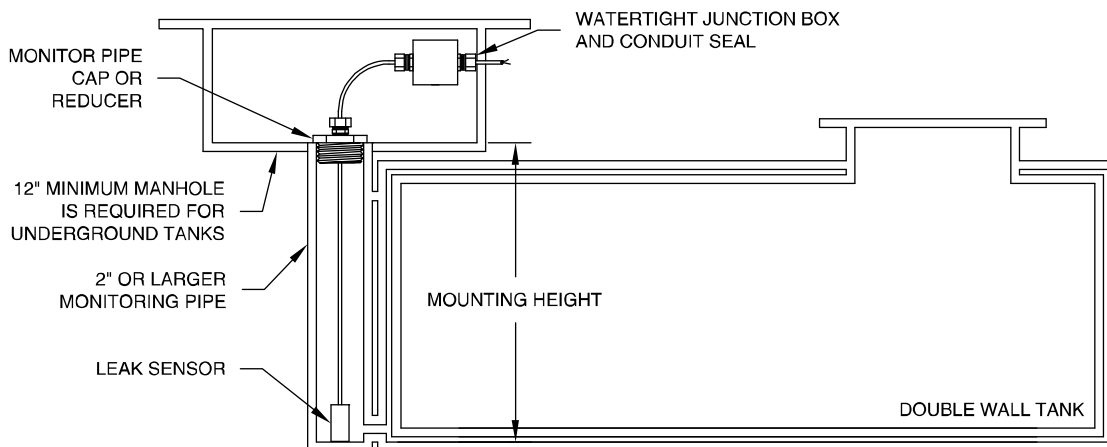
## EXTERNAL LEAK SENSOR INSTALLATION

The interstitial or double-wall space of steel tanks and vaulted tanks as well as many other secondary containment areas can be fitted with leak sensors. Also, for float type sensors, switch actuation may be factory set for either **NORMALLY OPEN** or **NORMALLY CLOSED**.

### 2.4 LEAK SENSOR INSTALLATION IN STEEL AND VAULTED TANKS

Check the specific design drawings for the job, or choose the sensor type desired from Figures 1-5 and 1-6. Install sensor per Figure 2-6 as follows:

1. Remove the watertight **CORD CONNECTOR** supplied by sliding it off the sensor cable.
2. Thread the watertight **CONNECTOR** into the top of a 2" by 1/2" reducer bushing or monitor pipe cap pre-tapped for a 1/2" NPT hole. (The use of any standard monitor cap from 2" to 4" pipe size is recommended. The cap or reducer bushing **IS NOT SUPPLIED** with the sensor and must be provided by the installer).
3. Measure the "**MOUNTING HEIGHT**" from top to bottom of monitoring pipe.
4. Feed the sensor cable through the watertight **CONNECTOR** from the **BOTTOM SIDE** of the **REDUCER** (or **CAP**) fitting to a cable length suitable for the **MOUNTING HEIGHT**; or to allow sensor to rest on the monitor pipe bottom; or as required by local codes. Cable may be cut or extended to proper length.
5. Re-tighten the **CORD CONNECTOR** to fix the sensor cable length.
6. Mate the **REDUCER** or **CAP** to the top of the monitor pipe. Tighten the **CONNECTOR** to ensure a **WATERTIGHT SEAL**.
7. Route the sensor cable to the junction box and complete the wiring installation in accordance with Section 3.



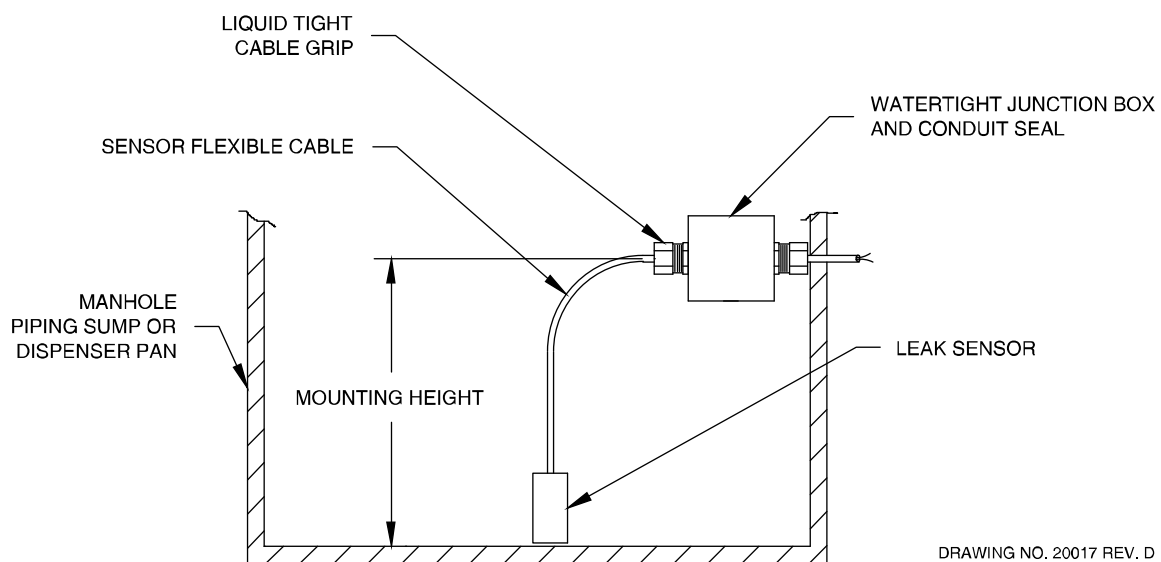
DRAWING NO. 20016 REV. C

**Figure 2-6 – Leak Sensor Installation - Steel Vaulted Tanks**

## 2.5 LEAK SENSOR INSTALLATION IN PIPING SUMPS AND DISPENSER PANS

Check the specific design drawings for the job, or choose the sensor type desired from Figures 1-5 and 1-6. Install sensor per Figure 2-7 as follows:

1. Measure the "MOUNTING HEIGHT" from conduit or junction box to the bottom of the SUMP (or MANHOLE, VAULT or DISPENSER PAN).
2. Feed the sensor cable through the watertight CONNECTOR to length suitable for the MOUNTING HEIGHT; or to allow sensor to rest on the containment bottom; or as required by local codes. Feed an additional 12 inches past the CONNECTOR for splicing inside the junction box; cable may be cut to proper length.
3. Thread the CONNECTOR into the WATERTIGHT JUNCTION BOX and tighten the CONNECTOR cord grip over the cable to insure a WATERTIGHT SEAL. The sensor should rest on the containment floor or as required by local codes.
4. Complete the wiring installation in accordance with Section 3.



**Figure 2-7 – Leak Sensor Installation in Piping Sumps, Manholes, and Dispenser Pans**

**2.6 LEAK SENSOR INSTALLATION IN FIBERGLASS TANK ANNULUS**

The annular space of fiberglass tanks can be fitted with either a "DRY ANNULUS" type sensor, models ES825 (Figure 1-6) and LS610 (Figure 1-7), or a "WET RESERVOIR" sensor model RSU800 (Figure 1-8). The wet reservoir is also referred to as the HYDROSTATIC METHOD. Check the specific design drawings for the job, or choose the type sensor desired from Figures 1-6 through 1-8. Install sensor per Figures 2-8 or 2-9.

Instructions per Figure 2-8, DRY ANNULUS SENSOR:

1. Calculate the sensor cable's MOUNTING LENGTH from tank size data so the sensor rests at tank bottom; or use the following method.

Determine the cable's MOUNTING LENGTH by adding the cable measurement M from the table at the right to the RISER HEIGHT. Mark the cable at that length. **DO NOT CUT THE CABLE.**

CABLE MEASUREMENT FROM END OF SENSOR	
Tank Dia.	Cable M
4 Feet	81 in.
6 Feet	118 in.
8 Feet	150 in.
10 Feet	194 in.
12 Feet	222 in.

2. Remove the watertight CORD CONNECTOR supplied by sliding it off the cable.
3. Thread the CONNECTOR into the top of a 2" by 1/2" reducer bushing or riser pipe cap pre-tapped for a 1/2" NPT hole. (The use of any standard monitor cap from 2" to 4" pipe size is recommended. The cap or reducer bushing IS NOT SUPPLIED with the sensor and must be provided by the installer).
4. At riser top, attach the annular space PULL CORD (this is part of the tank supplier's pre-installed accessories) to the sensor's PULL HOLE.
5. Pull the free end of the PULL CORD out of the riser while feeding the sensor into the riser and through the annular space until the sensor is at the bottom centerline of the tank. The MOUNTING LENGTH MARK should be about 5 INCHES above the open riser. Adjust its position as necessary and, without disconnecting the PULL CORD, coil its excess inside the riser pipe.
6. Feed the sensor cable through the BOTTOM of the riser cap (or bushing), and through the CORD CONNECTOR while positioning cap over the riser pipe. Mate riser and cap.
7. Tighten CONNECTOR over the cable to ensure a WATERTIGHT SEAL.
8. Complete the wiring installation in accordance with Section 3.

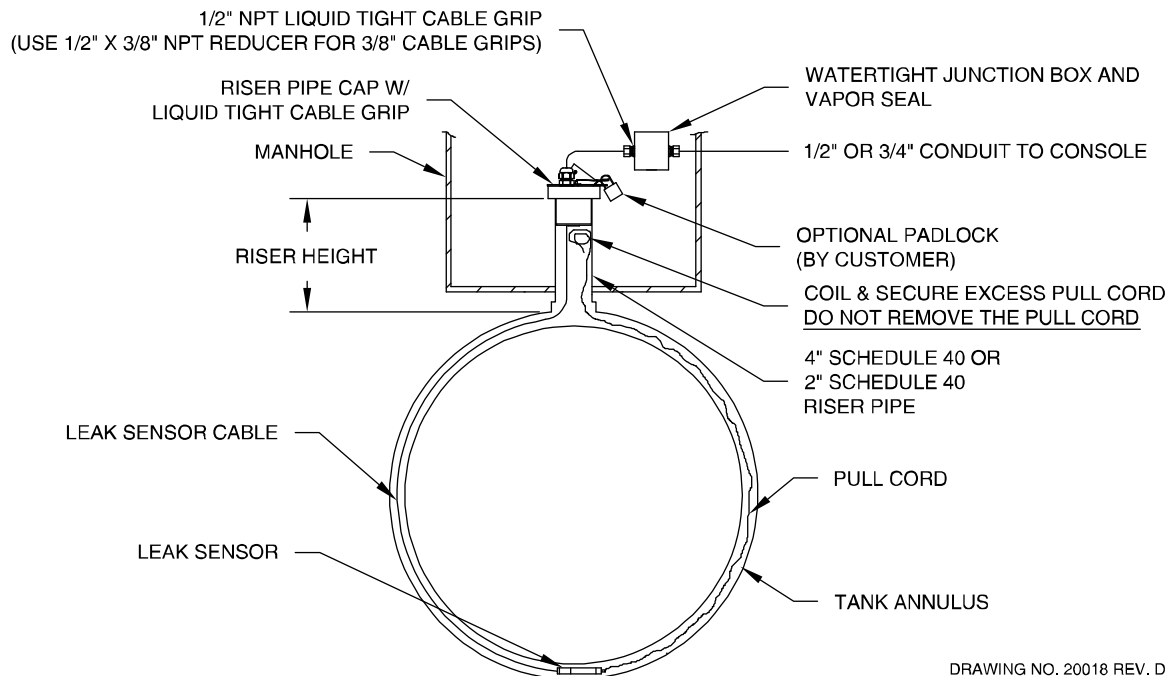


Figure 2-8 - Dry Leak Sensor Installation in Fiberglass Tanks

DRAWING NO. 20018 REV. D

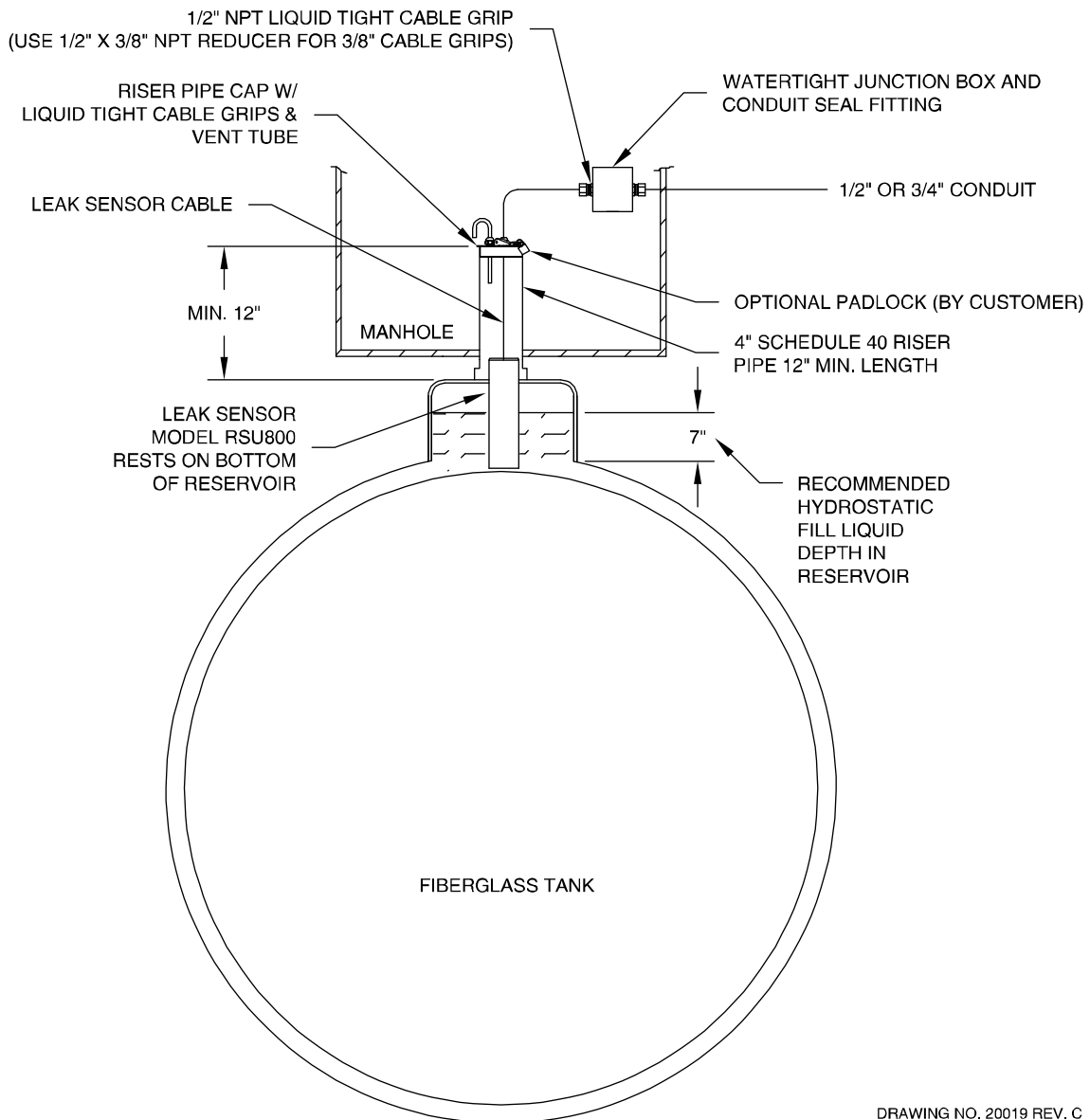
## 2.7 HYDROSTATIC LEAK SENSOR INSTALLATION IN FIBERGLASS TANK RESERVOIRS

The model RSU800 sensor uses a dual float that senses a HIGH and LOW liquid level within the reservoir. If a tank leak occurs through either wall of the DOUBLE-WALL tank the liquid level in the reservoir changes. When it reaches the upper or lower limits of the sensor a contact closure is transmitted to the control console.

Instructions per Figure 2-9, HYDROSTATIC LEAK SENSOR:

1. The tank reservoir should be fitted with a 4 inch RISER PIPE and CAP, supplied by THE INSTALLER. The riser should be at least 12 inches long as measured from the reservoir opening. The riser cap may be any standard type, but as a minimum it should have a 3/8" NPT tapped hole to accept the CORD GRIP CONNECTOR SUPPLIED BY PNEUMERCATOR, or contain its own suitable cord grip. (An alternate method is to drill and tap the wall of the riser pipe). The use of a riser cap with a VENT TUBE is only recommended where local installation requires one.
2. If the riser cap does not contain its own cord connector, thread the PNEUMERCATOR SUPPLIED CONNECTOR into the tapped hole using sealing compound as required. (Alternately, the CONNECTOR may be threaded into the sidewall of the riser).
3. Slowly lower the sensor into the riser until it rests on the reservoir bottom. The top portion should extend into the riser pipe for support from tipping over. The liquid level in the reservoir should be at about 7 inches up the sensor's height for optimum performance. (See Figure 1-8 for float travel set point limits).

4. Feed the sensor cable through the **BOTTOM** of the riser cap (or pipe wall), and through the **CORD CONNECTOR**. Leave just enough slack inside the riser pipe so the sensor remains on the bottom, and will not tip over.
5. Mate the riser and cap; tighten the **CONNECTOR** over the cable to ensure a **WATERTIGHT SEAL**.
6. Complete the wiring installation in accordance with Section 3.



DRAWING NO. 20019 REV. C

**Figure 2-9 – Hydrostatic Leak Sensor Installation in Fiberglass Tanks**

## **SECTION 3 WIRING INSTALLATION AND DIAGRAMS**

### **3.1 SYSTEM PROBE/SENSOR WIRING**

Figure 3-1 is a typical System Wiring Diagram that must be followed when running conduit and wires between the TANK area and the CONSOLE area. This follows NEC and other codes for proper installation.

PROBE AND SENSOR WIRING INSTALLATION. Refer to Figures 1-5 through 1-8 for console conduit openings and specific probe/sensors that will be wired into the TMS1000D system. Install wiring as follows:

1. Install 3/4" rigid conduit from all probe and sensor areas to the TMS1000D console.

### **⚠ CAUTION**

**All probe and sensor wiring from the TMS1000D console may be run in the same conduit. NO OTHER WIRING MAY BE RUN IN THESE CONDUITS. NEVER RUN POWER WIRES IN THESE CONDUITS. FAILURE TO COMPLY MAY RESULT IN PERSONAL INJURY, PROPERTY LOSS AND EQUIPMENT DAMAGE.**

2. At appropriate locations along the conduit runs (see Figures 2-4, 2-6, 2-7 through 2-12) install watertight couplings and approved VAPOR SEAL-OFF fittings.
3. At each probe/sensor location install a WATERTIGHT ELECTRICAL JUNCTION BOX. Allow enough room around the probe/sensor tank fitting for proper installation of the probe/sensor and all conduit/junction box fittings, and for later removal if necessary.
4. Attach the conduit at the TMS1000D console ONLY to the 1/2" conduit knockout located on the bottom LEFT SIDE. Use NEMA 4 fittings for outdoor locations.

**WIRING DRAWING - Tank Management System (TMS1000 SERIES)  
PREFERRED WIRING [No external junction box(es)] - See page 2 for alternate wiring**

**▲ FOR NON-FUEL, NON-INTRINSICALLY SAFE APPLICATIONS**

TABLE 1				
PROBE LEADER CABLE MAY HAVE ALTERNATE COLORS AS FOLLOWS				
+V	BRN	RED	RED	
GND	BLK	BLK	RED/BLK	
SHD	WHT	GRN	GRN	
IN	BLU	WHT	RED/WHT	
OUT	---	---	---	

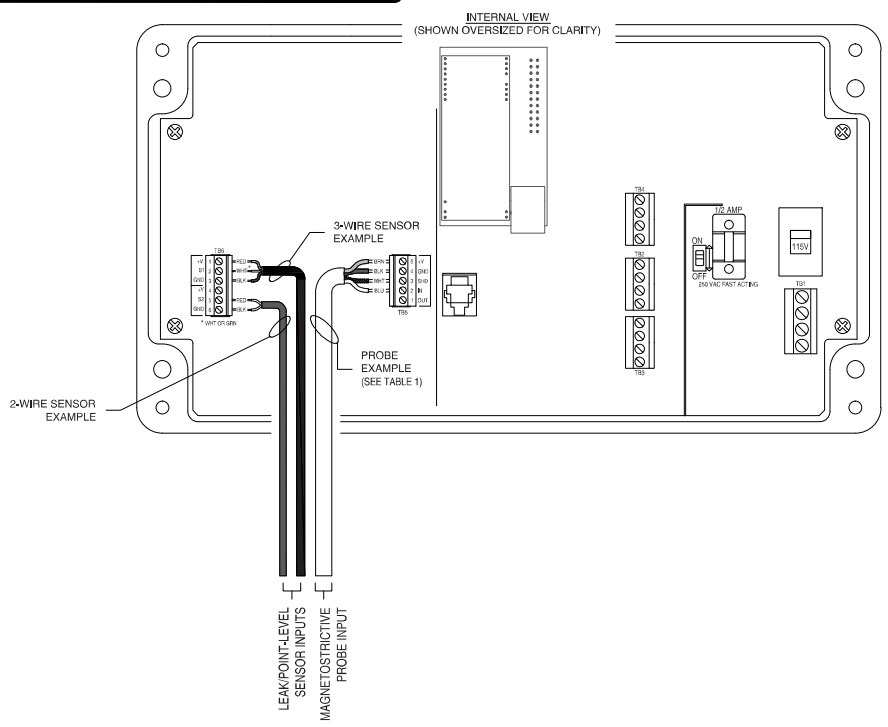


Figure 3-1a – Probe/Sensor Wiring Diagram - Preferred



## WIRING DRAWING - Tank Management System (TMS1000 SERIES) WIRING w/ EXTERNAL JUNCTION BOX(ES) - See page 1 for preferred wiring

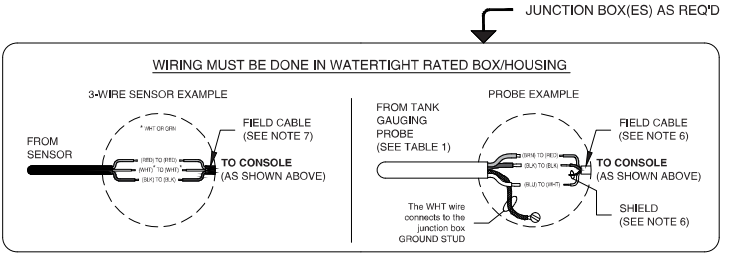
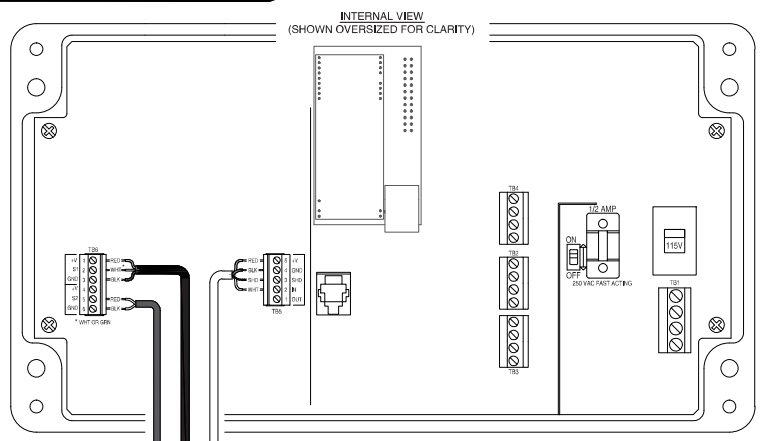
**▲ FOR NON-FUEL, NON-INTRINSICALLY SAFE APPLICATIONS**

**▲ IMPORTANT NOTES - READ CAREFULLY BEFORE INSTALLATION**

UNLESS OTHERWISE SPECIFIED:  
(NOTES 1-5 DO NOT APPLY TO THIS PAGE)

- 6. SHIELDED PROBE FIELD CABLE IS REQUIRED. THE SHIELD WIRE MUST BE CONNECTED TO THE PROBE SHIELD TERMINAL IN THE CONSOLE I.S. COMPARTMENT AND SHOULD BE CUT BACK AND LEFT UNTERMINATED AT THE PROBE JUNCTION BOX. PROBE CABLE LENGTH SHALL NOT EXCEED 50 FEET (15 METERS).
- 7. SHIELDED SENSOR FIELD CABLE IS NOT REQUIRED, BUT IF USED, THE SHIELD WIRE MUST BE CONNECTED TO THE SENSOR GROUND TERMINAL IN THE CONSOLE I.S. COMPARTMENT AND SHOULD BE CUT BACK AND LEFT UNTERMINATED AT THE SENSOR JUNCTION BOX. SENSOR CABLE LENGTH SHALL NOT EXCEED 50 FEET (15 METERS).

TABLE 1				
PROBE LEADER CABLE MAY HAVE ALTERNATE COLORS AS FOLLOWS				
+V	BRN	RED	RED	
GND	BLK	BLK	RED/BLK	
SHD	WHT	GRN	GRN	
IN	BLU	WHT	RED/WHT	
OUT	---	---	---	



JUNCTION BOX(ES) AS REQ'D

LEAKPOINT-LEVEL SENSOR INPUTS  
MAGNETO STRICTIVE PROBE INPUT

Figure 3-1b – Probe/Sensor Wiring Diagram - Splicing

5. Pull properly marked 2 to 4 conductor wiring (depending on probe/sensor configuration) for each probe/sensor through the conduit leaving at least 24 inches excess at both console and junction box ends for final connections. The field wires must be resistant to DEF liquids; type THHN or MTW, 22 AWG is recommended. Use Belden Cable part number 6501FE, or equivalent 3-conductor shielded cable, for the magnetostrictive probes only. This cable can be supplied by PNEUMERCATOR as part number CW16-0050.
6. Fill all conduit VAPOR SEAL-OFF FITTINGS with approved filling compound and tighten all conduit fittings.
7. Connect probe/sensor wires to the TMS1000D INPUT TERMINALS following Figure 3-1. Maintain correct polarity between wires and respective terminal points.
8. Probe and sensors should be logically identified as to location and type and recorded on the probe map provided in this manual, SECTION 3.6.

### CAUTION

**Probe and sensor wires are to be connected ONLY to the designated input terminals of the PROBE/SENSOR compartment. Do NOT allow probe/sensor wires to cross over into the POWER section. FAILURE TO COMPLY MAY RESULT IN PERSONAL INJURY, PROPERTY LOSS AND EQUIPMENT DAMAGE.**

3.2 POWER WIRING INSTALLATION

WIRING DRAWING - Tank Management System (TMS1000 SERIES)

▲ FOR NON-FUEL, NON-INTRINSICALLY SAFE APPLICATIONS

▲ IMPORTANT NOTES - READ CAREFULLY BEFORE INSTALLATION

UNLESS OTHERWISE SPECIFIED:  
(NOTES 6 & 7 DO NOT APPLY TO THIS PAGE)

1. CONSOLE CANNOT BE CONNECTED TO EQUIPMENT THAT USES OR GENERATES MORE THAN 250 VOLTS WITH RESPECT TO EARTH.
2. POWER TO THE TMS1000 CONSOLE SHOULD BE PROPERLY WIRED TO A SEPARATE DEDICATED 115/230 VAC CIRCUIT BREAKER.
3. SWITCH MUST BE SET TO 115 VAC FOR 115 VAC OPERATION AND 230 VAC FOR 230 VAC OPERATION.
4. DRY CONTACT SWITCH OUTPUT WIRING: WIRE TO COMMON AND EITHER NORMALLY OPEN OR NORMALLY CLOSED FOR DESIRED SWITCH CONTACT, OUTPUT RATED 5 AMPS AT 120 VAC, 5 AMPS AT 240 VAC (VOLTAGE MUST BE LESS THAN 120 VAC OR 240 VAC RESPECTIVELY).
5. NEC CLASS 2 CIRCUITS.

COMMUNICATIONS SLOT  
Optional Modem Card shown  
Refer to Installation Manual  
for other card options

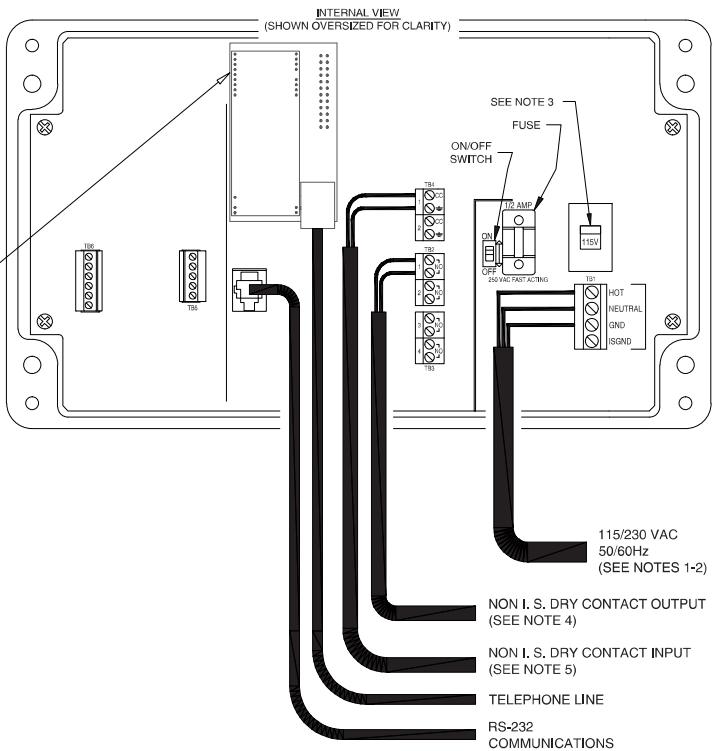


Figure 3-2 – Power, Communications, & Relay Wiring Diagram

3.3 PROBE/SENSOR WIRING & SPLICES

**IMPORTANT! TMS1000 SERIES PROBE AND SENSOR WIRING INSTRUCTIONS**

IDENTIFY THE TYPE OF PROBE AND/OR SENSOR(S) TO BE INSTALLED. WIRING MUST BE TERMINATED ON THE TERMINALS INDICATED BELOW TO ENSURE CORRECT OPERATION.

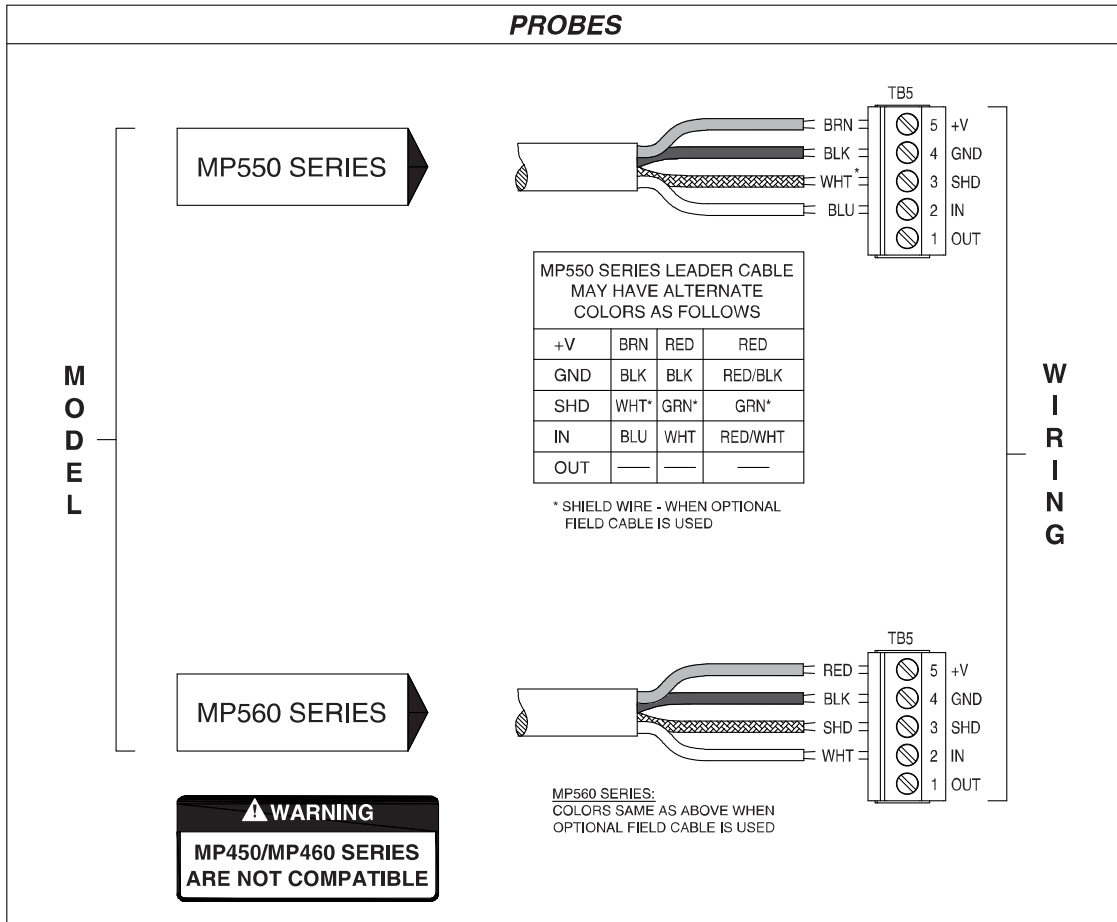
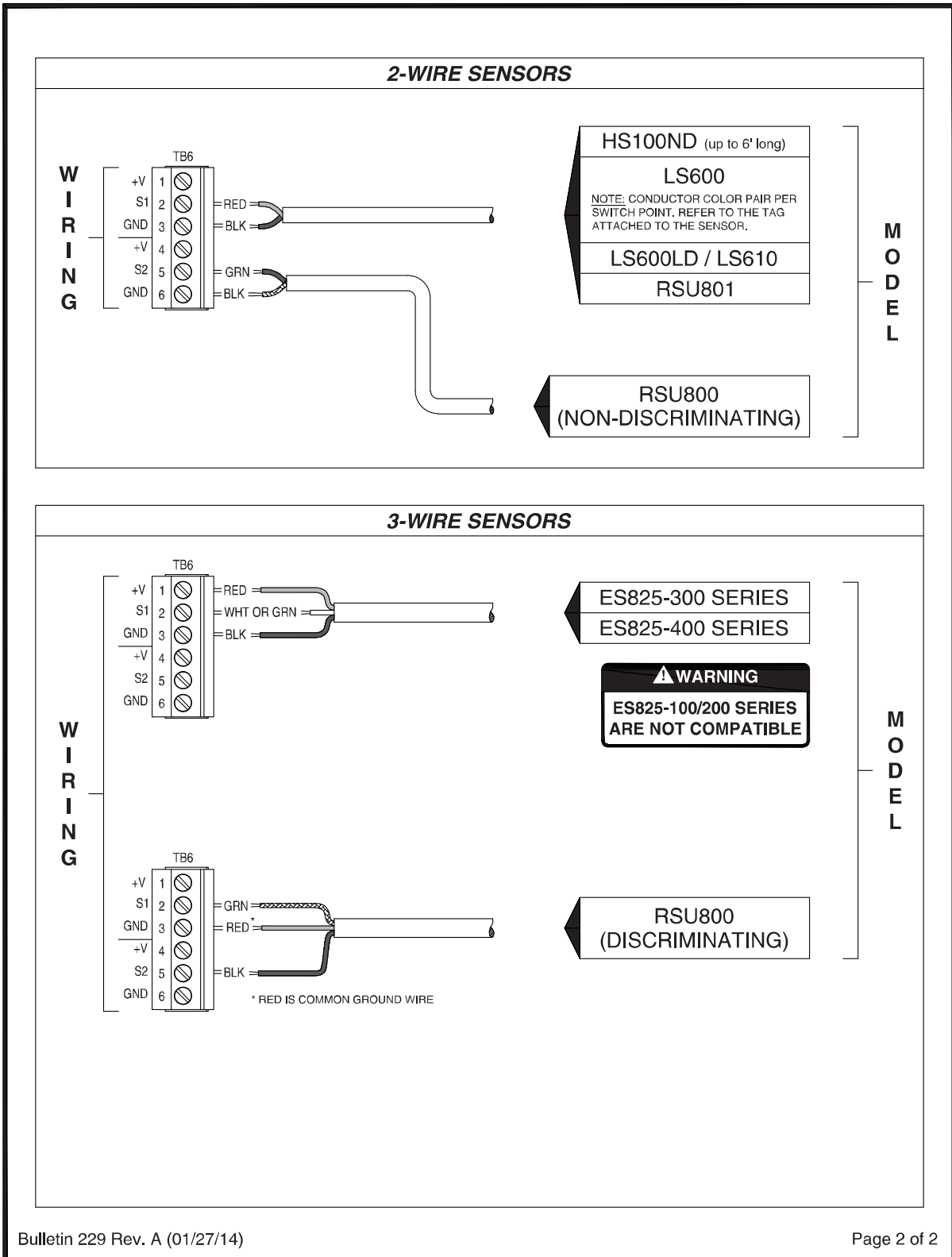


Figure 3-3a - TMS1000D probe wiring



### 3.4 PROGRAMMABLE RELAY OUTPUTS/CONTACT CLOSURE INPUTS

The TMS1000D provides dry contact closure inputs and relay contact closure outputs that are user-programmable via the console front panel or most TMS communications interfaces. Each input is programmable for relay control and alarm functions as well as remote relay acknowledgement or gating functions. Inputs may also be programmed to monitor submersible pump or generator activity. Each relay output is programmable to trigger on any combination of events, including theft, product, or temperature setpoints, leak or point level sensor alarm, contact closure input or system error. Additionally, relays are individually programmable for failsafe mode; delayed shutoff mode and a latching mode for pump up/down functions. Typical relay applications include remote annunciation, pump and siphon break/flow control valve operation, and other user-defined switch closure inputs. These relays also provide a simple and straightforward interface to most programmable logic controllers, building management systems, and similar input monitoring devices.

The standard TMS1000D includes two (2) dry contact closure inputs and four (4) relay contact closure outputs as illustrated in Figure 3-4 below.

## ⚠ CAUTION

**Relay output and contact closure input terminals are located on the RIGHT side of the console. ALL wiring to these terminals MUST enter through the designated conduit opening. Refer to FIGURE 2-1. FAILURE TO COMPLY MAY RESULT IN PERSONAL INJURY, PROPERTY LOSS AND EQUIPMENT DAMAGE.**

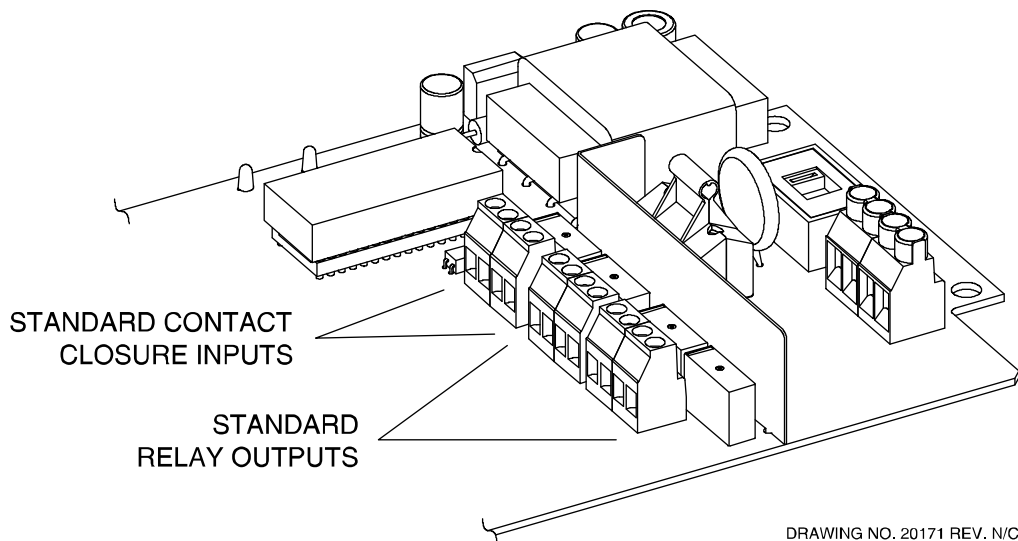


Figure 3-4 - Relay Output/Contact Closure Input Layout

### 3.5 DATA COMMUNICATIONS WIRING

The console's power area is equipped with two (2) communications ports that are assigned as follows:

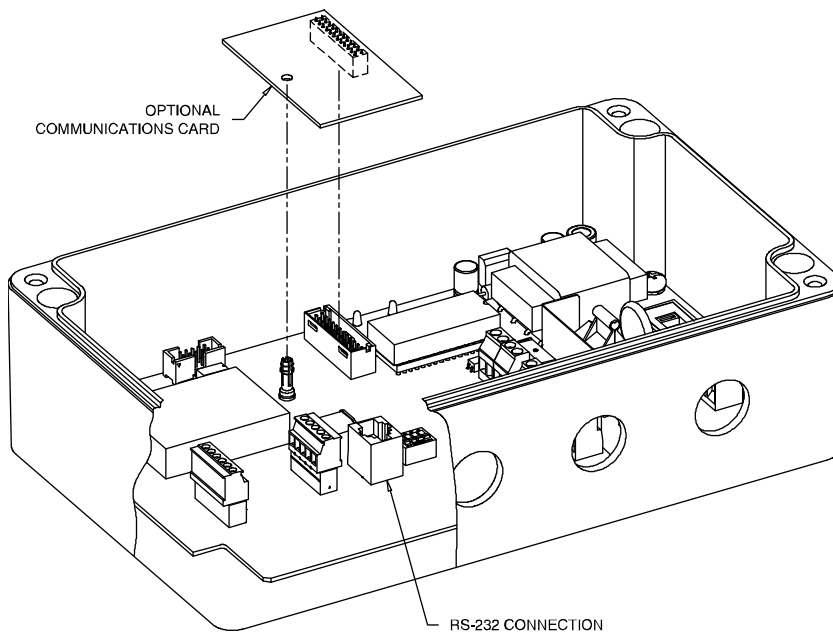
One (1) for external EIA RS-232 Interface to externally mounted computers or modems.

One (1) for use with an optional communications expansion board.

Figure 3-5 shows the locations of these ports.

## ⚠ CAUTION

**All communication terminations are located in the RIGHT side of the TMS1000D console. ALL wiring to these terminals MUST enter the designated conduit opening. Refer to FIGURE 2-1. FAILURE TO COMPLY MAY RESULT IN PERSONAL INJURY, PROPERTY LOSS AND EQUIPMENT DAMAGE.**



DRAWING NO. 20172 REV. N/C

Figure 3-5 - Communication Expansion Option Installation

**3.6 PROBE MAP/SYSTEM SETUP**

The probe map/system setup below should be completed by the electrical installer as each probe, sensor and control output function is wired to the TMS1000D system. This will provide the equipment operator a means of identifying each field device for proper system setup programming and use. The PROBE MAP should be adhered to or kept near the TMS1000D console.

**PROBE MAP/SYSTEM SETUP**

TANK	PRODUCT	SP 1	SP 2	SP 3
1				

CHNL	LEAK INPUT USAGE	SENSOR
1		
2		

CHNL	AUX/SWITCH INPUT USAGE	SENSOR
1		
2		

RELAY	ALARMS	USAGE
1		
2		
3		
4		









# PNEUMERCATOR TMS SERIES

## LIMITED WARRANTY

### TMS Series

**Pneumercator**, here and after referred to as **PCO**, warrants its **TMS Series** family of products to be free of defects in material and workmanship for a period of **Twelve (12) months** from date of installation or **Fifteen (15) months** from date of invoice, whichever comes first.

During the warranty period on the **TMS Series, PCO**, or factory third party independent representatives will repair or replace the product at the location where it is installed at no additional cost to the customer.

Packages must be inspected upon receipt for damage, missing parts, and/or manuals. **PCO** must be contacted by telephone immediately with a description of damaged or missing parts so replacements can be sent. Written details must be sent within **thirty (30) days**.

Pneumercator will not be responsible for shipping charges incurred by the customer.

Warranty repair coverage invoices will be paid if **all** the following conditions are met:

- PCO has acknowledged and authorized warranty work to be done by issuing a *Warranty Repair Number*.
- Start-up Service technician has been trained by PCO
- Warranty start-up form has been submitted to PCO
- Technician fills out and submits a PCO "Service Report"
- Parts (if any) used are returned to PCO with a proper WRGA (*Warranty Return Goods Authorization*)
- Returned parts are found to be defective.

Repair time will be paid according to PCO document "Standard Warranty Labor Charge Schedule"

If the Warranty Registration/Start up Check List has been completed and returned on file with the factory and the product is installed in accordance with the specific PCO Installation Product Manual, PCO will activate and meet warranty criteria as described above. Warranty criteria shall be voided if any product has been subjected to misuse, negligence, damage from acts of nature (lightning, wind, rain, etc.) or is in violation of the products design intent, disregard to warnings, instructions, modified or repaired by unauthorized personnel or improperly installed. Given that the third party independent contractor has installed the equipment in accordance with the specific product instruction manual, and followed all precautions, PCO will fulfill the terms stated in our warranty obligation.

Under no circumstances does the warranty provide a remedy in excess of the equipment. No other expressed or implied warranty is given by PCO. PCO shall not be liable for consequential damages or any expenses incurred by the user.

Distributed by:

 **PNEUMERCATOR**  
Liquid Level Control Systems

1785 Expressway Drive North, Hauppauge NY 11788  
(631) 293-8450 Fax (631) 293-8533