

ASSEMBLY INSTRUCTIONS - RISER MOUNTED MODEL:

MP42xS

MP45xS MP55xS

IMPORTANT! ALL of the following requirements must be met;

- Probe length does not exceed 15 feet.
- Tank does not contain chemicals, solvents or heated products where standard PVC leader cable is used.
- Tank does contain chemical, solvent or heated products where chemical/heat resistant probe assembly and leader cable are used and confirmed to be compatible with stored product.
- Tank is not pressurized.

Questions? Contact Technical Support at (800) 209-7858

FOR INSTALLATION AND WIRING SEE TMS MANUAL

1 Confirm you were supplied the correct number of floats (1 or 2). A Probe P/N with "21" or "25" suffix requires DUAL (2) floats while "11" or "15" suffix requires a SINGLE (1) float. Contact Pneumercator immediately if supplied Probe and number of floats do not match.

2 Trim spacers for the desired schedule 40 riser pipe diameter.

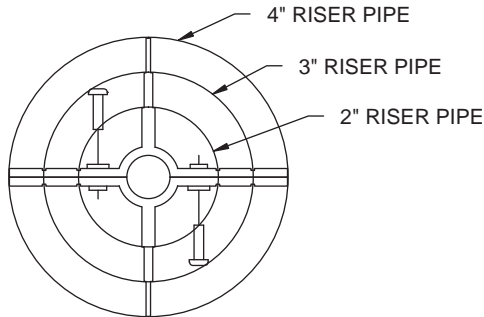

4 Assemble riser spacers.

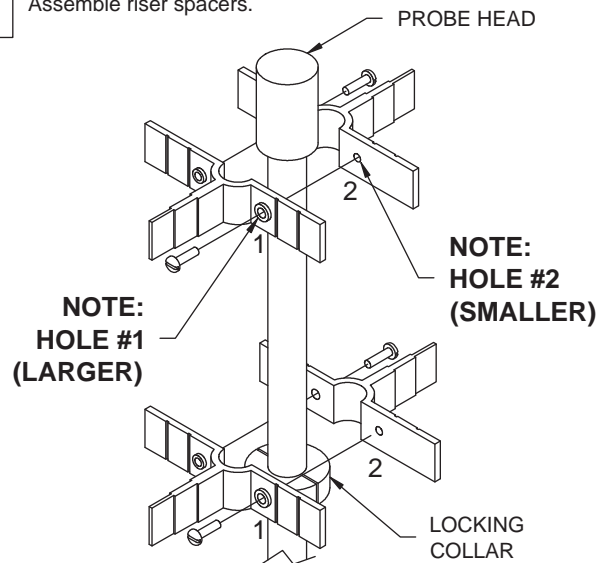

3 Verify that the bottom of the locking collar is located 8" from the top of the probe head and confirm that collar is secured.

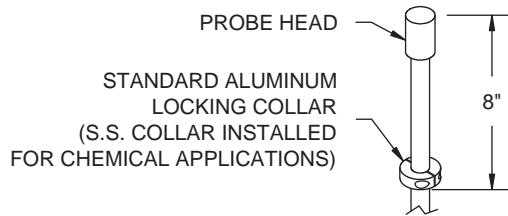

NOTE: AT THIS POINT MODEL MP452S/MP552S ASSEMBLY IS COMPLETE. PROCEED TO STEP 5 TO COMPLETE ASSEMBLY FOR ALL OTHER MODELS.

5 4" RISER MOUNTING ASSEMBLY

STANDARD APPLICATIONS

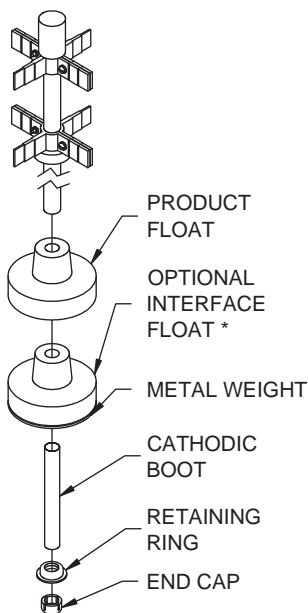

2" RISER MOUNTING ASSEMBLY

STANDARD APPLICATIONS

WITH INTERFACE * WITHOUT INTERFACE

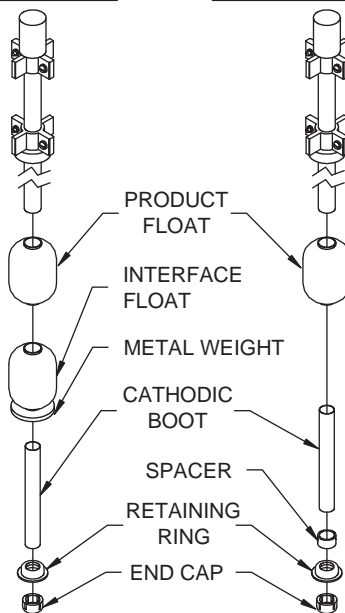

CHEMICAL APPLICATIONS

WITH INTERFACE * WITHOUT INTERFACE

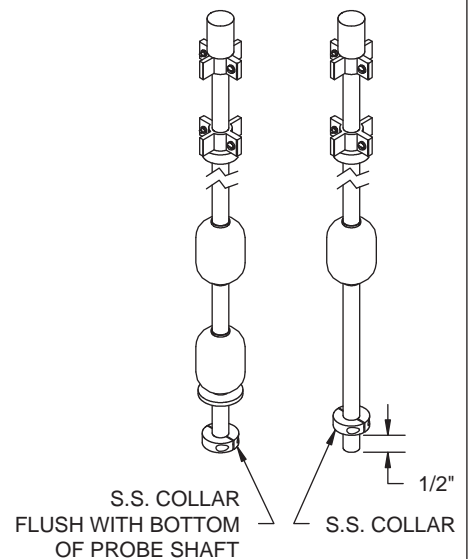

* NOT APPLICABLE FOR MP42xS

