

Pneumercator Hydrostatic Gauges – Manual Pump

Instructions for Installation and Adjustment

OPERATION

The Pneumercator P-Series Tank Gauge is designed to provide remote indication of the contents of vented storage tanks containing non-corrosive liquids.

Each time a reading is desired the pump should be operated until all liquid has been purged from the tubing and the pointer returns to the same spot between successive strokes.

The system operates on an adaptation of the hydrostatic principle. Operation of the manual pump pressurizes the transmission tubing and air bell. The pressure required to purge the line is equal to the back pressure of the tank liquid static head. Excess air escapes out the tank vent. The P-Gauge bellows expands in response to the back pressure exerted by the liquid head. The pointer, being linked to the bellows assembly, rotates to provide the read-out on a calibrated scale.

WARNING: This gauge should not be used on unvented tanks, for corrosive liquids, or on tanks whose diameter and capacity vary from those shown on the dial.

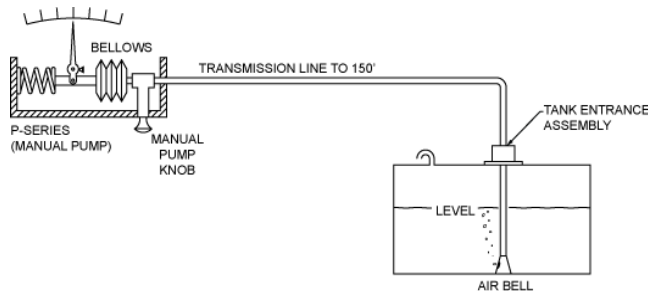

INSTALLATION

The system can be installed in an empty or full tank by personnel without any special tools or skills. Installation of the air bell and tube is through a 2" NPT tank opening. Pneumatic transmission lines should be protected from accidental damage by installation in 3/4" electrical conduit. Sweep ell or wide radius bends should be used where bends are necessary.

Mount the gauge securely on a wall in a location where it will be both visible and accessible.

Lower the air bell through the tank opening until it rests on the bottom. Screw in the reducing bushing and compression fitting taking the slack from the tubing inside the tank before tightening but making sure the air bell remains on the bottom. Run the tubing to the gauge being careful that it does not become distorted or plugged. It is desirable to have the tubing drain from the gauge to the tank, avoiding low spots or pockets where moisture can collect. Buried tubing can be protected by taping it to the underside of the oil suction pipe.

Before tubing is attached to gauge make sure the pointer is exactly on the first mark (empty position) on the dial. If it is necessary to zero the pointer, see the adjustments section.

Tank Pressure: Vented tank.

Tank Distance: 150 feet, maximum.

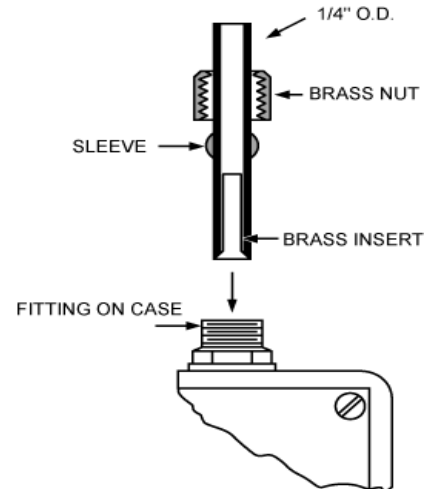

Cut off any excess tubing. Install the brass insert into end of tubing, slip first brass nut then plastic sleeve over the tubing as shown above. Insert tubing into fitting on gauge, slide plastic sleeve and brass nut down and fasten tubing securely to gauge.

TROUBLESHOOTING

If the pointer oscillates between pump strokes and gradually comes to rest, check for a liquid accumulation in a low pocket of the tubing.

If the pointer remains on "Empty" while the pump is operated, make sure there is liquid in the tank, check for a leaking connection between tubing and gauge, check for damaged tubing and check that the air bell is on the bottom of the tank.

If the tank is partly empty and the pointer remains on "Full" between strokes of the pump, check for an obstruction in the tubing or crushed tubing.

It is possible to localize malfunctions in the tank and transmission assembly or in the gauge by disconnecting the tubing from the gauge. Place thumb over the tubing connection and operate the pump to observe for normal pointer travel.

If the pointer does not return to "Empty" after the tubing has been disconnected, rezero the gauge by following the procedure described in Adjustments.

Additional repair or replacement of gauge parts in the field is not recommended. Return the gauge directly to the factory and attach a letter with your name, address, and description of the trouble encountered.

CAUTION: Do not use detergents, solvents, paint thinners, lighter fluids, or chemical cleaning compounds to clean the gauge. Use only a damp, soft cloth and a mild soap.

Pneumercator Hydrostatic Gauges – Manual Pump

Instructions for Installation and Adjustment

ADJUSTMENT

Pneumercator Tank Gauges are calibrated and adjusted at the factory specifically for the tanks on which they are to be installed. Actually, no further adjustment should be required but due to minor variations in tank diameter it may be necessary to reposition the pointer to the empty position.

Loosen compression nut which secures the tubing to the fitting on top of the gauge. This vents the system which is necessary before any adjustment is made. Follow the instructions below for your specific P-Gauge.

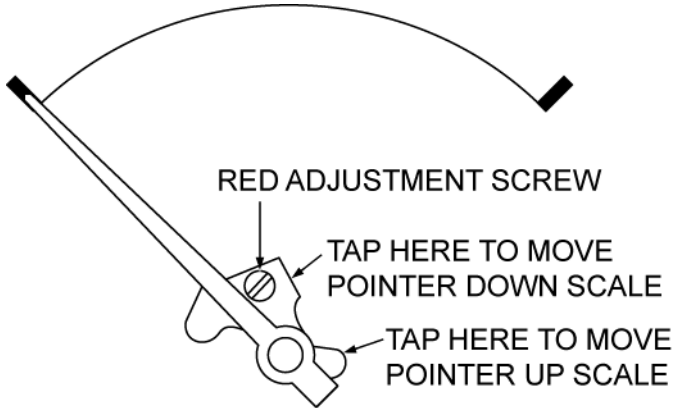

P-5

P-5: Remove 4 cover screws and cover. Slightly loosen the red adjusting screw. Tap the mechanism as illustrated above until the pointer indicates empty. Retighten red screw and reinstall the cover with 4 cover screws and the compression nut with tubing.



P-11, P-14: Remove 4 cover screws and cover. The pointer is held to the hub by 2 - #1-72 screws. Loosen each screw slightly. Reposition the pointer so that the pointer tip is in the center of the large increment representing the empty position. Tighten the #1-72 screws and recheck the pointer position. Reinstall the cover with 4 cover screws and the compression nut with tubing.

P-29: Remove 4 cover screws and cover. The pointer is held to the hub by 2 - #1-72 screws. Loosen each screw slightly. Reposition the pointer so that the pointer tip is in the center of the large increment representing the empty position. Tighten the #1-72 screws and recheck the pointer position. Reinstall the cover with 4 cover screws and the compression nut with tubing. If the pointer cannot be fully adjusted using this method, you may perform additional adjustments by inserting a small flat blade screwdriver into the hole in the face marked ADJUST. Carefully rotate the screw until the needle is correctly positioned.

NOTES

Although the P-Gauge itself is accurate to within approximately 2% of scale, the total system accuracy is a combination of the P-Gauge, tank, installation, and measured liquid. If the gauge appears to be out of tolerance after the pointer has been repositioned, consider the following possibilities:

1. Tank geometry could be different than what the P-Gauge was built to support. Some reasons for this discrepancy are as follows:
 - a. Tank not level
 - b. Tank bowed due to slinging
 - c. Tank manufacturing tolerances
 - d. Devices within the tank (Heaters, Coils, etc.) reduce tank capacity
 - e. Tank linings and coatings can also reduce capacity
 - f. Improperly vented tank
2. Be certain the air bell is resting on the tank bottom.
3. Check that the specific gravity of the liquid, grade of fuel oil, and tank dimensions are as specified on your purchase order. If the actual data appreciably differs from your order and the readings are unacceptable, the gauge must be returned with accurate information for rework.

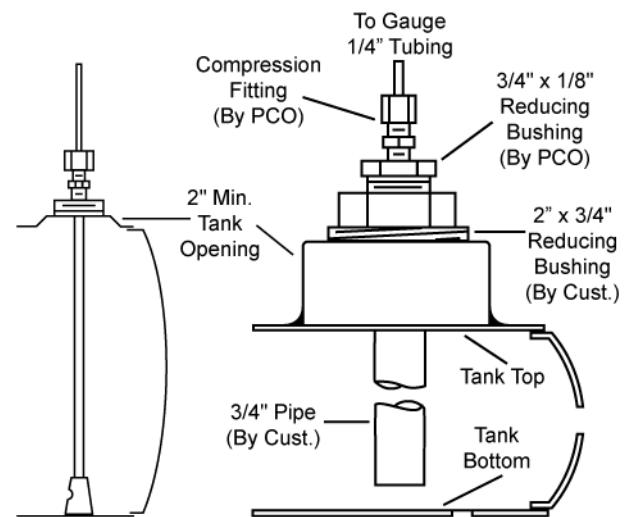

For Tanks Up To
10'-6" In Diameter

For Tanks Over
10'-6" In Diameter
And No. 6 Oil