

INSTRUCTION MANUAL

Revised: November 24, 2004

LDE 9000 Series

LDE 9001

LDE 9002

LDE 9004

© COPYRIGHT 2004 PNEUMERCATOR CO.
120 FINN COURT, FARMINGDALE, N.Y. 11735
(631) 293-8450 Phone
(631) 293-8533 Fax
(800) 209-7858 Product Support
www.pneumercator.com

Preface

NOTICE: PNEUMERCATOR CO., INC. reserves the right to make improvements to the product described in these instructions at any time and with no notice.

WARNING: This equipment generates, uses, and can radiate radio frequency energy and if not installed and used in accordance with the instruction manual, may cause interference to radio communications. It has been tested and found to comply with the limits for a Class A computing device pursuant to Subpart B of Part 15 of FCC Rules, which are designed to provide reasonable protection against such interference when operated in a commercial environment. Operation of this equipment in a residential area is likely to cause interference in which case the user at his own expense will be required to take whatever measures may be required to correct the interference.

IMPORTANT: Installation of this equipment must be in accordance with these instructions as adopted from the following codes:

ISA RP12.6, "Installation of Intrinsically Safe Instrument Systems in Class I Hazardous Locations".

NFPA 70, "National Electrical Code".

Alteration, modification or replacement with non-factory components could impair the intrinsic safety of this equipment.

OPERATION AND INSTALLATION MANUAL

Table of Contents

Preface

Section 1: INTRODUCTION	1
Section 2: INSTALLATION	3
Section 2.1: Mechanical Installation	3
Section 2.2: Sensor Installation	3
Section 2.3: Electrical Installation	6
Section 2.4: Installation Checklist	7
Section 3: OPERATION	8
Section 3.1: Normal Operation	8
Section 3.2: The Horn	9
Section 3.3: The Relay Contacts	10
Section 3.4: Test Mode	10
Section 3.5: Calibrate Mode	11
Section 3.6: Maintenance	12
Section 4: SPECIFICATIONS	13
Section 5: TROUBLESHOOTING & SERVICING	14
Figure 1: BOARD LAYOUT	17
Figure 2: 9-901 INSTALLATION DRAWING	18
Figure 3: 9-902 INSTALLATION DRAWING	19
Figure 4: 9-903 INSTALLATION DRAWING	20
Figure 5: WIRING DIAGRAM - 1 SENSOR	21
Figure 6: WIRING DIAGRAM - 2 SENSORS	22
Figure 7: WIRING DIAGRAM - 3 SENSORS	23
Figure 8: WIRING DIAGRAM - 4 SENSORS	24
Figure 9: INTRINSICALLY SAFE LOOP	25
Figure 10: SPECIFICATIONS	26
Figure 11: DIMENSIONS	27
Warranty	

OPERATION AND INSTALLATION MANUAL

Section 1: INTRODUCTION

The PNEUMERCATOR model LDE 9000 system is a capacitance based system designed to monitor collection sumps and the annular spaces of double wall tanks for leakage of hydrocarbons. The system provides individual indications for detection of air, water, and hydrocarbons. Detection of air is indicated by a Green light. Detection of hydrocarbons is indicated by a Red light, and by sounding of an audible alarm. Detection of water is indicated by an Amber light, and optionally by sounding of an audible alarm.

The system will retain memory of an alarm condition even if that alarm condition later disappears. If relay actuation for water detection for a sensor is selected, the relay for that sensor will remain actuated even if the water alarm disappears. This alarm memory is battery backed up, so the memory will remain in the event of a power failure. The alarm memory may be cleared by either placing the system in calibration mode, or by pressing the TEST and RESET buttons at the same time.

A single-pole double-throw dry relay contact, rated for use at up to 5 Amps at 120 VAC is provided for each sensor. Normally closed, common and normally open contacts are brought out to a terminal block, and when hydrocarbons are detected the relay is energized and the contacts change state. Relay actuation is optionally available for water detection as well as hydrocarbon detection. Communication of a fault condition may be transmitted any distance from the alarm console by connecting data transmission equipment to the relay contacts for that sensor.

The adjustable volume system horn will sound an audible alarm while the selected alarm conditions are present. Audible alarm silencing may be done by manually by pressing the RESET button on the cover of the alarm console, or may be automatically timed for a selectable automatic time delay reset. Time delay periods of 1, 3, and 5 minutes are available for standard operation.

The TEST button is used to test the operation of the system alarm console, turning on all lights and the horn. During test operation, horn reset may be tested by manually pressing the RESET button, or by waiting for the selected time delay period. Pressing the TEST and RESET buttons at the same time will also clear any retained memory of hydrocarbon alarm conditions.

OPERATION AND INSTALLATION MANUAL

Sensors may be tested and calibrated by placing the system in CALIBRATE mode. This calibration is done with the sensors in air. The sensor calibration will reset the system air calibrations and will test for proper sensor operation. Installation of new sensors, up to system capacity, and replacement of existing sensors may be done by selecting the number of sensors and then placing the system in CALIBRATE mode. Sensors for both sump and annular space detection may be mixed in a system with no limitations. Placing the system in CALIBRATE mode will also clear any retained memory of hydrocarbon alarm conditions.

The system alarm console may be mounted in any non-hazardous area where it can be provided with 120 VAC $\pm 10\%$ at 60 Hz. The system sensors are designed for intrinsically safe operation in Class I, Division 1, Group A, B, C, D areas. The sensors may be separated from the alarm console by 3-wire 18 AWG runs of up to 1000 feet. The system alarm console is supplied in a NEMA 4 watertight enclosure, and may be mounted outdoors. The fuse for the alarm console is a ¼ Amp, 3AG Slo-Blo type.

The system is designed to provide safe and reliable operation when installed as instructed in the Installation section of this manual. All requirements of the National Electrical Code (NEC) as well as local electrical and fire codes should be followed in the installation procedures. It is recommended that the user should read and understand ANSI/ISA RP12.6, "Installation of Intrinsically Safe Instrument Systems in Class I Hazardous Locations".

If additional information is needed concerning equipment selection, system planning, installation, operation, or servicing or maintenance, please contact:

PNEUMERCATOR CO., INC.
120 Finn Court
Farmingdale, New York, 11735
(631) 293-8450 Phone
(631) 293-8533 Fax
(800) 209-7858 Product Support
www.pneumercator.com

OPERATION AND INSTALLATION MANUAL

Section 2: INSTALLATION

NOTE: INSTALLATION MUST BE DONE BY QUALIFIED PERSONNEL, FAMILIAR WITH LOCAL WIRING CODES AND EXPLOSION HAZARD ELECTRICAL SAFETY PRACTICES.

Section 2.1: Mechanical Installation

The LDE 9000 alarm console is housed in a NEMA 4 enclosure. This enclosure is intended for indoor or outdoor installation and offers protection against splashing water, seepage of water, falling of hose directed water, and severe external condensation. The enclosure is also sleet resistant. The enclosure has mounting flanges, which allow permanent fastening to walls, panels, etc.

The alarm console should be located in an area that is easily accessible to the personnel responsible for operating the system. This is to allow easy maintenance access, and access to the console for operation and testing. The console must be located in a non-hazardous area, as close as possible to the demarcation point of the hazardous area, with available 120 VAC power brought to the console through a dedicated metal wiring conduit. The metal conduits for sensors and power should be weather tight. Bottom entrance holes are provided for ½" NPT pipe or rigid metal conduit, with sensors entering on the bottom left and power entering on the bottom right.

Consult the local electrical codes for specific requirements.

Section 2.2: Sensor Installation

There are three leak detection sensors available. The Model 9-901 is designed for installation in the annular space of F.R.P. double-wall tanks. The Model 9-902 is designed for installation in 2" collection sumps, monitoring pipes and steel double-wall tank sumps. Both units are supplied with a 2" NPT mounting bushing, a ½" NPT liquid tight compression fitting and 25 feet of sensor cable. The Model 9-903 is designed for installation in collection sumps, monitoring pipes and double-wall tank sumps that are 1.25" in size. It is supplied with 25 feet of sensor cable and a ½" NPT liquid tight compression fitting. A 1.25" square pipe cap is optionally available as part number 900379-1.

Three (3) 18 AWG wires are required for each sensor. The wiring should be run through NEMA 4 or better junction boxes and ½" weatherproof liquid tight metal conduit. The metal conduit and junction boxes should be sealed against entry of water. If required, vapor seals may be installed to prevent gas vapors from propagating back to the alarm console. The sensor wiring to the alarm console should be run in a dedicated metal wiring conduit. No other wires should be in the same conduit unless a metal barrier is provided.

OPERATION AND INSTALLATION MANUAL

Console wiring (see Figure 1, Page 21 for board layout)
(see Figures 5 to 9, Pages 24 to 25 for wiring diagrams)

The sensors are wired to TB1 on the alarm console board. The first sensor is wired to positions 1 to 3, and if there is a second sensor it is wired to positions 4 to 6. The Red wire is connected to position 1, the White wire is connected to position 2 and the Black wire is connected to position 3. If there is a second sensor, the Red wire is connected to position 4, the White wire is connected to position 5 and the Black wire is connected to position 6.

The wiring and terminal block on the left side (TB1) are intrinsically safe and are physically separated from the AC power and relay contact wiring and terminal block on the right side (TB2). This separation must be maintained.

9-901 Installation (see Figure 2, Page 22 for drawing)

Tank size	Measurement length
4'	81"
6'	118"
8'	149.5"
10'	193.5"
12'	222"

1. Use the chart above to determine the cable measurement length for the size of the tank being monitored.
2. Unroll the sensor/cable assembly and measure from the sensor bottom to the cable measurement length. Mark the cable at that point.
3. Feed the cable through the bottom of the mounting bushing and cord connector until the mark on the cable is even with the top of the mounting bushing. Insert the sensor and cable through the 2" NPT opening and into the annular space.
4. Screw in the mounting bushing and connector.
5. Tighten the connector with the cable mark in the correct position.
6. Wire the sensor cable end to three 18 AWG wires in a NEMA 4 or better junction box or in an optional epoxy splice kit, part number 100007-1.

OPERATION AND INSTALLATION MANUAL

9-902 Installation (see Figure 3, Page 23 for drawing)

1. Measure the distance from the top of the 2" opening to the bottom of the area being monitored. This is the mounting height.
2. Add 2 and 3/16 inches to this dimension to find the cable length measurement.
3. Unroll the sensor/cable assembly and measure from the sensor bottom to the cable measurement length. Mark the cable at that point.
4. Feed the cable through the bottom of the mounting bushing and cord connector until the mark on the cable is even with the top of the mounting bushing. Insert the sensor and cable through the 2" NPT opening.
5. Screw in the mounting bushing and connector.
6. Tighten the connector with the cable mark in the correct position.
7. Wire the sensor cable end to three 18 AWG wires in a NEMA 4 or better junction box or in an optional epoxy splice kit, part number 100007-1.

9-903 Installation (see Figure 4, Page 24 for drawing)

1. Measure the distance from the top of the opening to the bottom of the area being monitored. This is the mounting height.
2. If using the optional Pneumercator leak monitor tube assembly for Convault tanks (assembly #900379-1), add 1 inch to this dimension to find the cable length measurement.
3. Unroll the sensor/cable assembly and measure from the sensor bottom to the cable measurement length. Mark the cable at that point.
4. Feed the cable through the bottom of the tube cover and cord connector until the mark on the cable is visible. Insert the sensor and cable through the monitoring opening.
5. Screw the cord connector into the tube cover and place back on the tube.
6. Tighten the connector with the cable mark in the correct position.
7. Wire the sensor cable end to three 18 AWG wires in a NEMA 4 or better junction box or in an optional epoxy splice kit, part number 100007-1.

OPERATION AND INSTALLATION MANUAL

Section 2.3: Electrical Installation

WARNING: Do not connect 120 VAC or turn on 120 VAC until all other connections have been made, all equipment has been installed, and final inspection has been completed.

The LDE 9000 alarm console requires a power input of 120 VAC, $\pm 10\%$, 60 Hz. The unit is fused with a ¼ Amp, 3AG Slo-Blo fuse. Total power usage is less than 30 Watts. The power input is protected against common-mode power surges with a metal-oxide varistor (MOV). The power line for the alarm console should not share a breaker circuit with any motors, compressors, or other sources of power surges or voltage sags. The power wiring to the alarm console should be run in a dedicated metal wiring conduit. No other wires should be in the same conduit unless a metal barrier is provided. Three wires make up the power input to the LDE 9000 alarm console - Black (hot), White (neutral) and Green (ground).

The A.C. power wires run to the terminal block labeled TB2, to positions 7, 8 and 9. Position 7, labeled 120VAC, is the hot lead. Position 8, labeled NEUT is the neutral lead. Position 9, labeled GND is the ground lead. The terminal blocks will accept wire sizes up to 14 AWG stranded wire. The wiring and terminal block on the left side (TB1) are intrinsically safe and are physically separated from the AC power and relay contact wiring and terminal block on the right side (TB2). This separation must be maintained.

Note that for multiple printed circuit board consoles, power need only be wired to the right hand circuit board.

IMPORTANT

Connect a 12 AWG copper wire from the terminal block TB3 (labeled Earth Ground) to a good earth ground. The ground connection must be within 1 OHM of true ground and must be made at only one point for the system to maintain intrinsic safety.

Properly dress all wires inside the wiring sections and securely clamp down the enclosure door and tighten all conduit entrances to seal the system watertight. Install vapor seals in accordance with local codes for hazardous locations if applicable.

OPERATION AND INSTALLATION MANUAL

Section 2.4: Installation Checklist

Do not apply power to the unit until its installation has been checked and found to be in accordance with the instructions in this manual; the National Electrical Code; federal, state and local codes; and other applicable safety codes.

1. Check to be sure that the sensor wires are contained in a dedicated, separate metal wiring conduit.
2. Verify that all conduits enter the alarm console through the proper conduit openings on the bottom of the console.
3. Verify that a 12 AWG has been connected between TB3 (labeled Earth Ground) and a good earth ground.
4. Verify that the power supply terminals are correctly wired.
5. Verify that system power is properly wired to a separate, dedicated circuit breaker.
6. Verify that all sensors have been properly wired with color-coded or marked 18 AWG wires and that the proper color-coding or marking has been maintained throughout the wiring runs.
7. Securely clamp down the alarm enclosure door.

OPERATION AND INSTALLATION MANUAL

Section 3: OPERATION

IMPORTANT: Before operating the LDE 9000 system, make sure that all items on the installation checklist in the Installation section of this manual have been checked out and complied with.

Make sure that the configuration dip switch (S1) position #8 is set for the proper number of sensors installed in the alarm board (see Figure 1, Page 21 for switch location and board layout).

Configuration Dip Switch (S1 on alarm board)

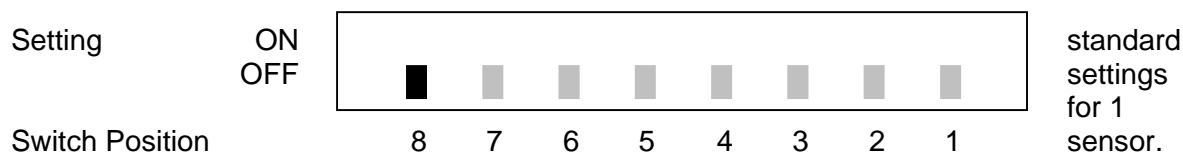

Configuration Dip Switch (S1 on alarm board)

Switch	Function	Meaning
1	Horn on water for sensor 1	OFF, ON
2	Horn on water for sensor 2	OFF, ON
3	Relay on water for sensor 1	OFF, ON
4	Relay on water for sensor 2	OFF, ON
		} also selects alarm latch feature.
5	Automatic reset select 1	see chart on
6	Automatic reset select 2	page 12 for times.
7	Calibrate mode select	OFF=RUN, ON=CALIBRATE
8	Number of sensors	OFF=1 SENSOR, ON=2 SENSORS

Section 3.1: Normal Operation

Each sensor that is installed in the alarm board controls a set of 3 lights and a set of relay contacts. All sensors share a horn, a RESET button and a TEST button for the system.

In normal operation, one light will be on for each installed sensor. If no fault condition exists this will be the Green air light. If the sensor detects water the Amber water light will be on. If the sensor detects hydrocarbons (the minimum detection depth is 1/8 inch) the Red hydrocarbon light will be on. The light for the detected condition will remain on for as long as that condition persists. Unused alarm console sensors will have no lights on.

OPERATION AND INSTALLATION MANUAL

Section 3.2: The Horn

The horn will always sound an audible alarm on detection of hydrocarbons by one or more sensors. The volume of the audible alarm may be controlled by rotating the louver on the face of the horn. The maximum volume of the horn is a minimum of 85 dB at two feet, and the loudness may be varied by about 40 dB.

The horn may be reset (silenced) after detection of a warning condition by pressing the RESET button on the cover of the alarm console. This will silence the horn, but the condition light will remain on. The horn control has two options that may be used - horn actuation on detection of a water condition and timed automatic horn reset.

The alarm console is normally set at the factory to only actuate the horn on hydrocarbon detection, not on water detection. In order to enable actuation of the horn on water detection the configuration dip switch position for horn on water for that sensor must be changed. Dipswitch S1 position 1 controls horn on water actuation for sensor 1, while dip switch S1 position 2 controls horn on water actuation for sensor 2. If the dip switch position for the sensor is set to the "OFF" position the horn will sound only on hydrocarbon detection for that sensor. If the dip switch position for the sensor is set to the "ON" position the horn will sound on either hydrocarbon or water detection for that sensor.

The alarm console is normally set at the factory to disable the automatic horn reset function. This setup will let the horn sound on detection of the hydrocarbon condition (or water condition if selected) until it is manually silenced by pressing the RESET button on the alarm console cover. Dipswitch S1 positions 5 and 6 must be changed to enable the automatic horn silence function. When the automatic horn silence function is enabled, the horn will automatically shut off after a pre-selected time delay. The manual horn silence operation remains functional. The standard automatic time delays, which may be selected, are 1, 3 and 5 minutes. The chart below gives the dipswitch settings used to select the various time delay settings.

<u>Switch pos. 5</u>	<u>Switch pos. 6</u>	<u>Setting</u>
OFF	OFF	time delay disabled
ON	OFF	1 minute delay
OFF	ON	3 minute delay
ON	ON	5 minute delay

OPERATION AND INSTALLATION MANUAL

Section 3.3: The Relay Contacts

Each sensor in the system has associated with it a set of SPDT dry relay contacts. The terminal block relay contacts for each sensor (TB2 positions 1 - 6) consist of Normally Closed (NC), Common (C) and Normally Open (NO) positions. These contacts are rated to 5 amps at 120 VAC. Wire sizes up to 14 AWG stranded wire may be used to connect to these relay contact outputs. In normal operation with air detected by a sensor, there is no continuity between the Normally Open (NO) and Common (C) contacts and there is continuity between the Normally Closed (NC) and Common (C) contacts. When a hydrocarbon condition is detected (or water if selected) the relay actuates. This gives continuity between the Normally Open (NO) and Common (C) contacts, and breaks continuity between the Normally Closed (NC) and Common (C) contacts. Relay contacts remain closed or open while the detected condition persists and are unaffected by the horn silence reset function.

The alarm console is normally set at the factory to only energize the relays on detection of hydrocarbons. If is desired that the relays also energize on detection of water for a sensor the dipswitch S1 positions 3 and/or 4 must be changed. Dipswitch position 3 controls relay actuation on water detection for sensor 1 and dipswitch position 4 controls relay actuation on water detection for sensor 2. In the "OFF" position the relay will energize only on hydrocarbon detection. In the "ON" position the relay will energize on either hydrocarbon or water detection. If a hydrocarbon alarm condition is detected and relay actuation on water detection is selected, the relay will remain energized even if the hydrocarbon alarm condition later disappears. This alarm relay latch feature may be cleared by placing the system in CALIBRATE mode, by pressing the TEST and RESET buttons at the same time, or by placing dip switch positions 3 and/or 4 in the "OFF" setting.

Each sensor channel is independent of the other in these settings. Relay contact option settings have no effect on the horn option settings.

Section 3.4: Test Mode

The TEST button on the cover of the alarm console is used to test the operation of the system alarm console. Pressing the TEST button turns on all lights and the horn. The relays are also actuated, changing the state of the dry relay contacts. Test mode continues for as long as the TEST button is pressed. During test operation, horn reset may be tested by manually pressing the RESET button, or by waiting for the selected time delay period. When the TEST button is released, the system resumes normal operation. Pressing the TEST and RESET buttons at the same time will also clear the system memory of any retained hydrocarbon alarms.

OPERATION AND INSTALLATION MANUAL

Section 3.5: Calibrate Mode

Calibration of the sensors is done by making sure that the sensors are in air, and then placing the system in Calibrate mode. The system is placed in Calibrate mode by setting dipswitch S1 position 7 to the "ON" position. The system is in Run mode when dipswitch S1 position 7 is in the "OFF" position. The unit should be allowed to warm up for 30 minutes before calibration is ended if calibration is being performed upon power turn-on.

The system will indicate that it is in Calibrate mode by turning on all the lights and shutting off the system horn. When the Calibrate switch is returned to the "OFF" position, the system will resume Run mode. If the Calibrate switch is left in the "ON" position, the system will remain in Calibration mode. The process of calibration takes less than a second to complete. The Calibration procedure will also clear the system memory of any retained hydrocarbon alarms.

The system is calibrated at the factory and it is normally unnecessary to recalibrate the sensors on installation. Sensor calibrations are retained in battery backed memory that has a data retention period of 10 years. This will ensure retention of sensor calibrations when the unit is powered down or has a power failure. Other than maintenance, it is normally necessary to recalibrate the system only if a sensor is being added to the system, if a sensor is being replaced, or if it is desired to clear any retained hydrocarbon alarm conditions from the system memory.

Calibration mode will test the sensors as well as the system battery backed memory. If the memory fails the test, the system will indicate this by turning on the air and water lights and turning off the hydrocarbon light. The system will remain in this state until the calibration memory is replaced. This is to ensure that proper operation of the system is maintained. If memory failure is indicated by the system, please contact the factory for repair information. If a sensor fails the calibration test or the wiring is bad, the system will indicate this by turning off all the lights for that sensor or by turning on the water light when calibration mode is ended. The memory and sensor failure tests are automatically performed each time the system is powered on.

TEST LIGHT INDICATIONS

<u>Air</u>	<u>Water</u>	<u>Hydrocarbon</u>	<u>Meaning</u>
on	on	on	calibrations running
on	on	off	memory failure
off	off	off	sensor failure
off	on	off	water alarm

OPERATION AND INSTALLATION MANUAL

Note: Sensor failure or water alarm will also be indicated if a sensor is disconnected from the system, is not present, or there is bad wiring between the sensor and the system alarm console. See Section 5: TROUBLESHOOTING & SERVICING.

Section 3.6: Maintenance

The time between maintenance periods is a variable that will depend upon the environment in which the sensors and alarm console are operating. The alarm console should be tested every six months by pressing the TEST button on the cover. See Section 3.4: Test Mode.

The sensors should be visually inspected for fouling or clogging at least once a year. A fouled or clogged sensor can give false alarms. If the sensor is fouled or clogged, it should be cleaned with soap and water or a mild solvent, and unclogged with compressed air. After visual inspection, the sensors should be reinstalled, and recalibrated. See Section 3.5: Calibrate Mode, and Section 5: TROUBLESHOOTING & SERVICING.

If an actual leak occurs, after corrective action is taken, the sensors should be cleaned, inspected and recalibrated before reinstallation.

OPERATION AND INSTALLATION MANUAL

Section 4: SPECIFICATIONSPower Input

120 VAC \pm 10%, 60 Hz.
Fuse - 1/4 AMP, 3AG Slo-Blo.

Power-to Field Sensor

Low electrical energy: 5 VDC at 62.5 mA supplied to each sensor. Intrinsically safe for Class I, Division 1, Groups A, B, C, D.

Control Relay Output

Dry switch contact - SPDT per sensor, selectable for oil or oil/water, rated 5 Amps at 120 VAC. Normally closed, common and normally open contacts provided.

Response Time

Less than 1 second.

Hydrocarbon Detection Depth

1/8 inch min.

Indicators/Controls

Red light indicates oil detection.
Amber light indicates water detection.
Green light indicates air (normal condition).
Horn signals alarm - 85 dB min. at 2 feet (adjustable).
Reset button silences horn.
Automatic timed horn reset available.
Test button tests alarm box outputs.
Calibrate mode for testing/installation of sensors.
Red and Amber or Green light indicates alarm memory.

Enclosure

NEMA 4 watertight enclosure.

Installation

Wall mount standard.

Temperature

Sensors: operation from -40°C to +55°C.
(-40°F to +130°F).
Alarm console: operation from -18°C to +41°C.
(0°F to +105°F).

Sensor Cable

Standard 3 conductor #18 AWG.
Up to 1000 feet (by customer).

OPERATION AND INSTALLATION MANUAL

Section 5: TROUBLESHOOTING & SERVICING

PNEUMERCATOR CO., INC.
 120 Finn Court
 Farmingdale, N.Y. 11735
 (631) 293-8450 Phone
 (631) 293-8533 Fax
 (800) 209-7858 Product Support

The PNEUMERCATOR LDE 9000 system and all components are factory warranted for a period of 1 year from the date of shipment. No materials should be returned to the factory without first getting a Returned Materials Authorization number from PNEUMERCATOR. All materials returned should be marked with this R.M.A. number.

Because of the intrinsically safe operation of the system no field repairs other than fuse changing should be attempted. All repairs should be done only at the factory or at a factory authorized repair center.

SYMPTOM: No lights are on for any sensor and system does not respond to pressing TEST button.

ACTION: Make sure that 120 VAC power is connected to the power connection terminal block and that the power is turned on. With power off, check the fuse labeled F5 to make sure that it is not blown. If the fuse is blown, replace only with a 1/4 Amp, 3AG Slo-Blo fuse. If system still does not respond, call factory for servicing.

SYMPTOM: No lights are on for a sensor, system responds to pressing TEST button.

LIGHT INDICATIONS

<u>Air</u>	<u>Water</u>	<u>Hydrocarbon</u>	<u>Meaning</u>
off	off	off	sensor failure

ACTION: Check to make sure that all sensor wires are connected to the proper terminal block contacts. Make sure that the conduit wires in the run from the sensor to the alarm console have continuity and are not shorted to each other. A sensor that has the power wire (marked R) or input wire (marked W) disconnected or shorted to ground will show the sensor failure indication. Make sure that the metal conduits and the sensor housing do not have water in them. If all wiring is correct, call factory for servicing or sensor replacement.

OPERATION AND INSTALLATION MANUAL

SYMPTOM: More than 1 light is on for a sensor, system responds to pressing TEST button.

LIGHT INDICATIONS

<u>Air</u>	<u>Water</u>	<u>Hydrocarbon</u>	<u>Meaning</u>
on	on	on	calibrations running

ACTION: Make sure that dipswitch position 7 is in the "OFF" position to shut off calibration mode.

SYMPTOM: More than 1 light is on for a sensor, system responds to pressing TEST button.

LIGHT INDICATIONS

<u>Air</u>	<u>Water</u>	<u>Hydrocarbon</u>	<u>Meaning</u>
off	on	on	alarm memory state
on	off	on	alarm memory state

ACTION: Clear the alarm memory condition by placing the system in calibration mode, or by pressing TEST and RESET buttons at the same time.

SYMPTOM: More than 1 light is on for a sensor, system does not respond to pressing TEST button.

LIGHT INDICATIONS

<u>Air</u>	<u>Water</u>	<u>Hydrocarbon</u>	<u>Meaning</u>
on	on	off	memory failure

ACTION: Call factory for servicing.

SYMPTOM: System gives false water alarm.

LIGHT INDICATIONS

<u>Air</u>	<u>Water</u>	<u>Hydrocarbon</u>	<u>Meaning</u>
off	on	off	water alarm

ACTION: Check to make sure that the sensor is in contact only with air. Make sure that the ground wire (marked B) and the sensor input wire (marked W) have continuity from the sensor to the alarm console. Make sure that the sensor input wire (marked W) is not shorted to power. Place system in Calibrate mode with the sensor in air. If sensor still does not work properly, call factory for servicing.

OPERATION AND INSTALLATION MANUAL

SYMPTOM: System gives false alarms.

ACTION: Check to make sure that the sensor is in contact only with air. Pull sensor from installation and make sure that it is not fouled or clogged. If sensor is fouled or clogged, clean with soap and water solution or a mild solvent and dry and unclog with compressed air. Place system in Calibrate mode with the sensor in air. Check all wiring for continuity, proper connections and make sure that there are no shorts. If sensor still does not work properly call factory for servicing.

When the sensor has been immersed in water, it takes a period of time for the sensor to drain completely and dry. During this time the sensor will oscillate between water/ hydrocarbon and hydrocarbon/air readings. This will cause the hydrocarbon alarm to latch into the system memory. This may be cleared when the sensor is dry and in air by either pressing the TEST and RESET buttons at the same time or by putting the system into Calibrate mode.

OPERATION AND INSTALLATION MANUAL

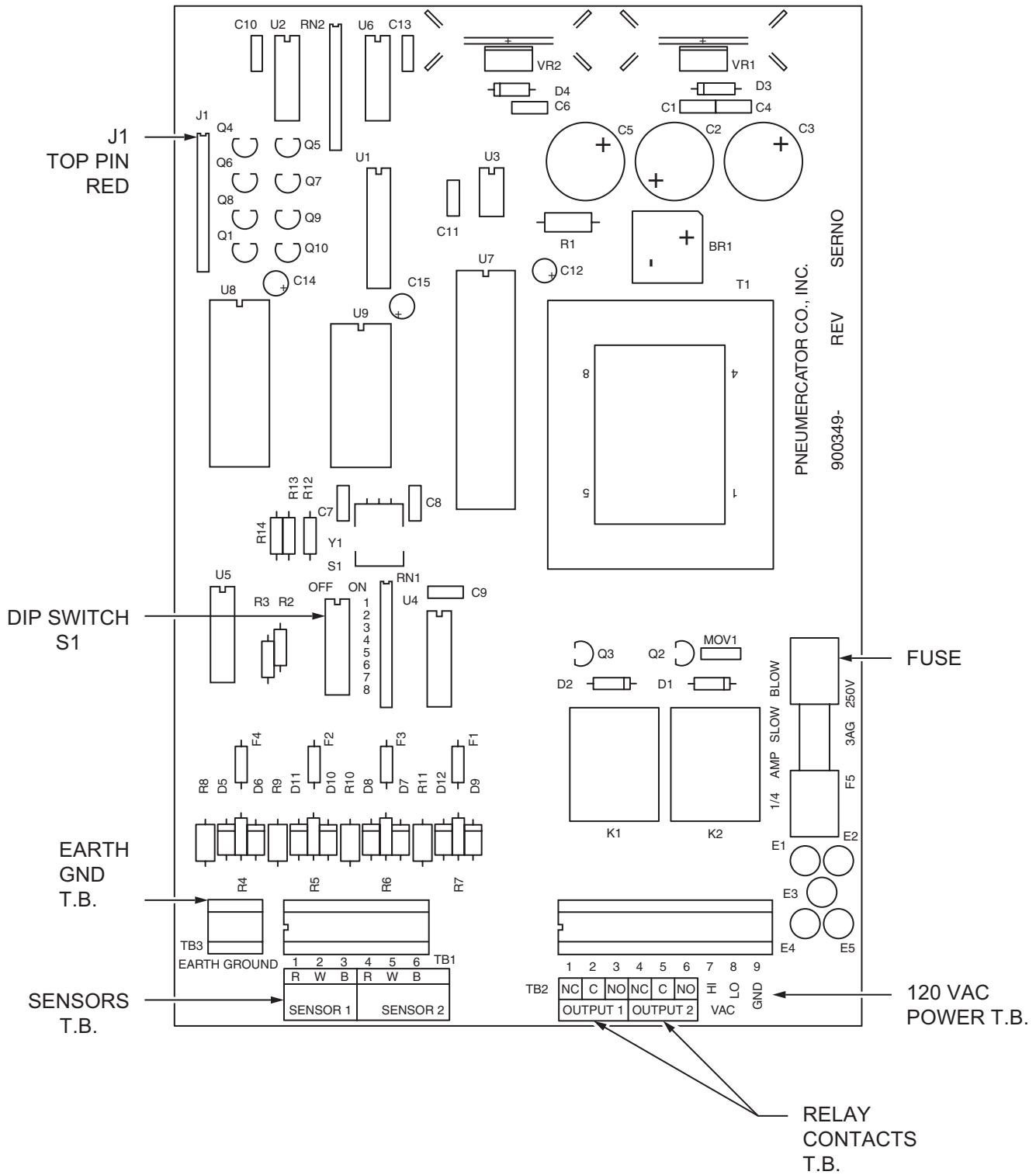

Figure 1 - Board Layout

OPERATION AND INSTALLATION MANUAL

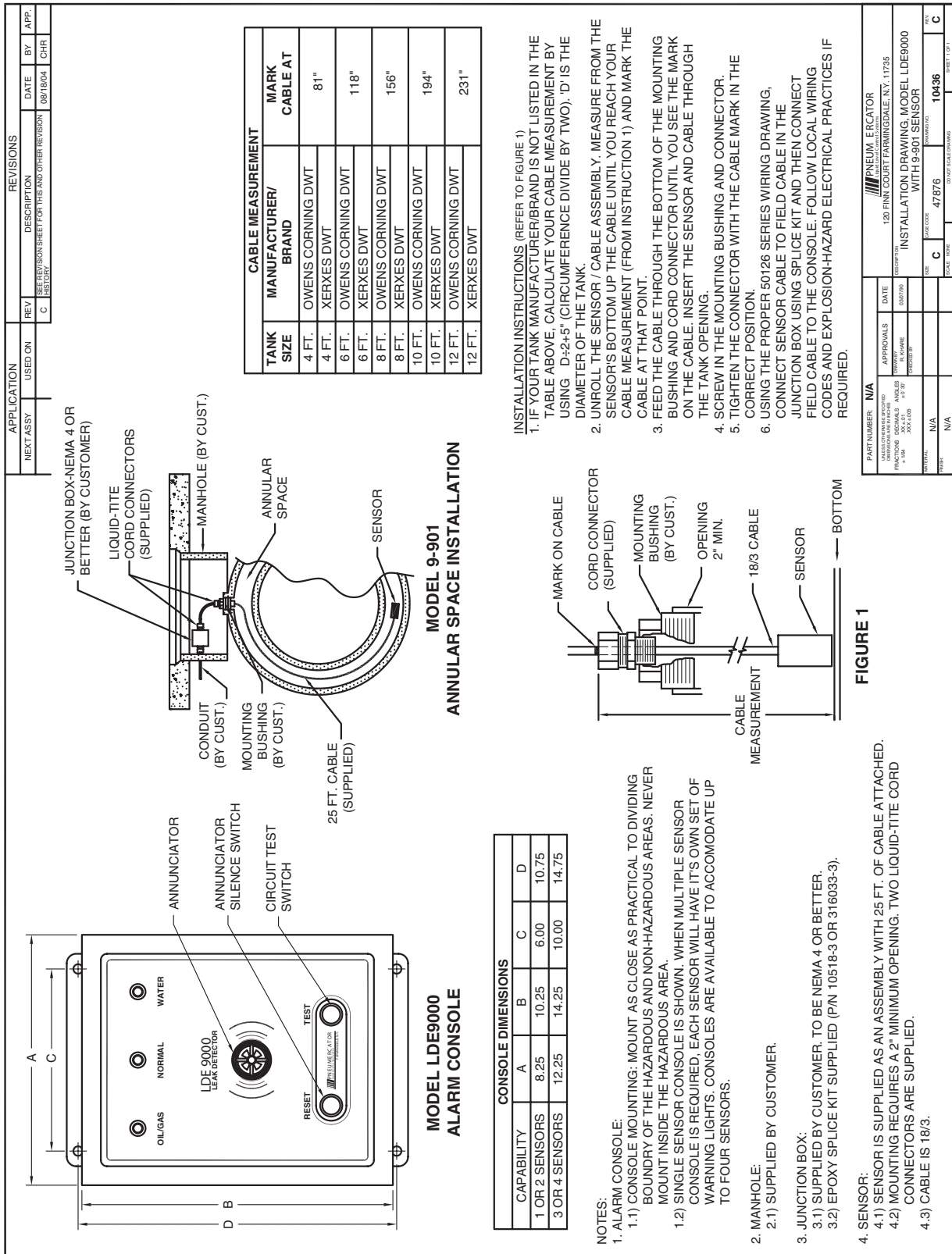

Figure 2 - 9-901 Installation

OPERATION AND INSTALLATION MANUAL

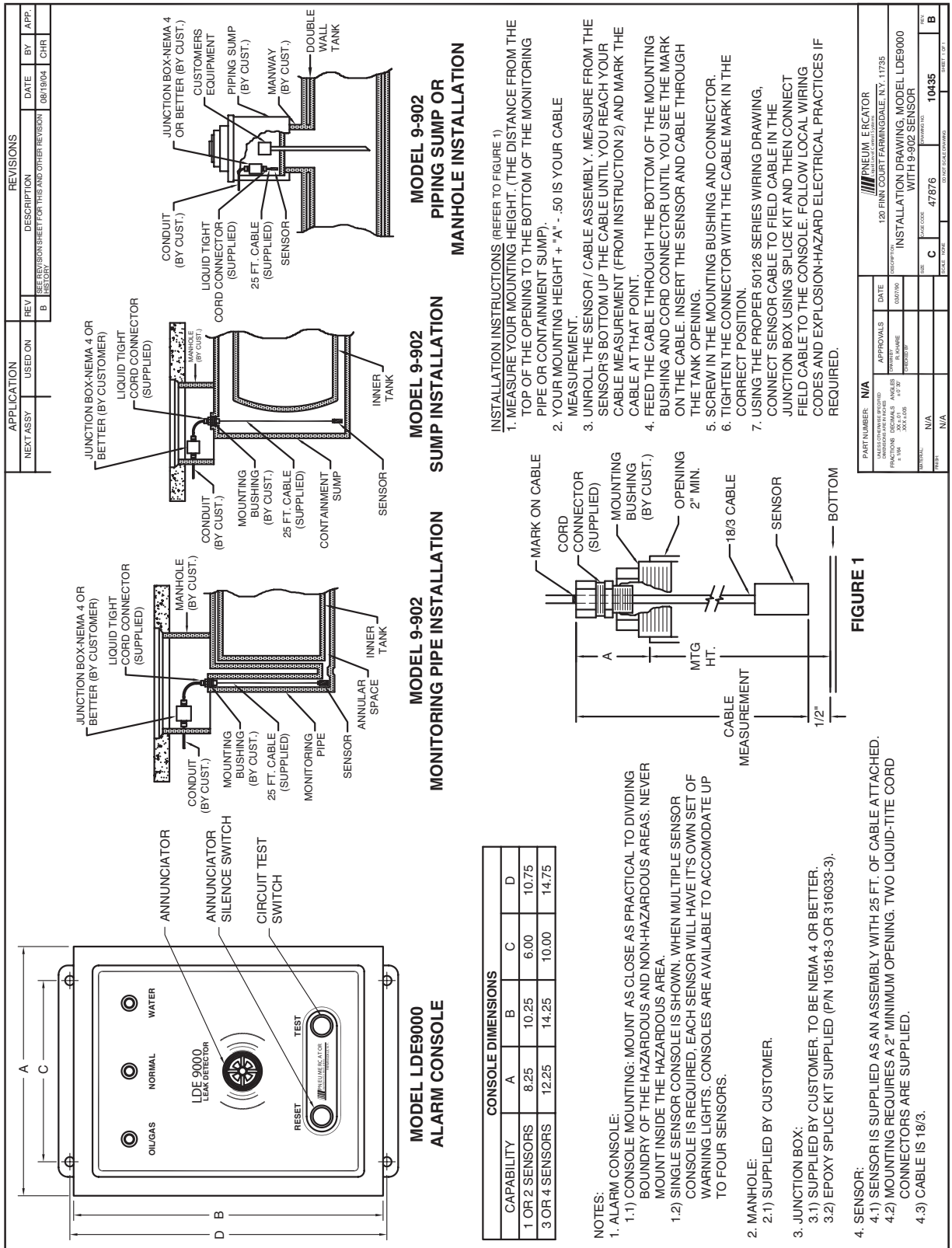

Figure 3 - 9-902 Installation

OPERATION AND INSTALLATION MANUAL

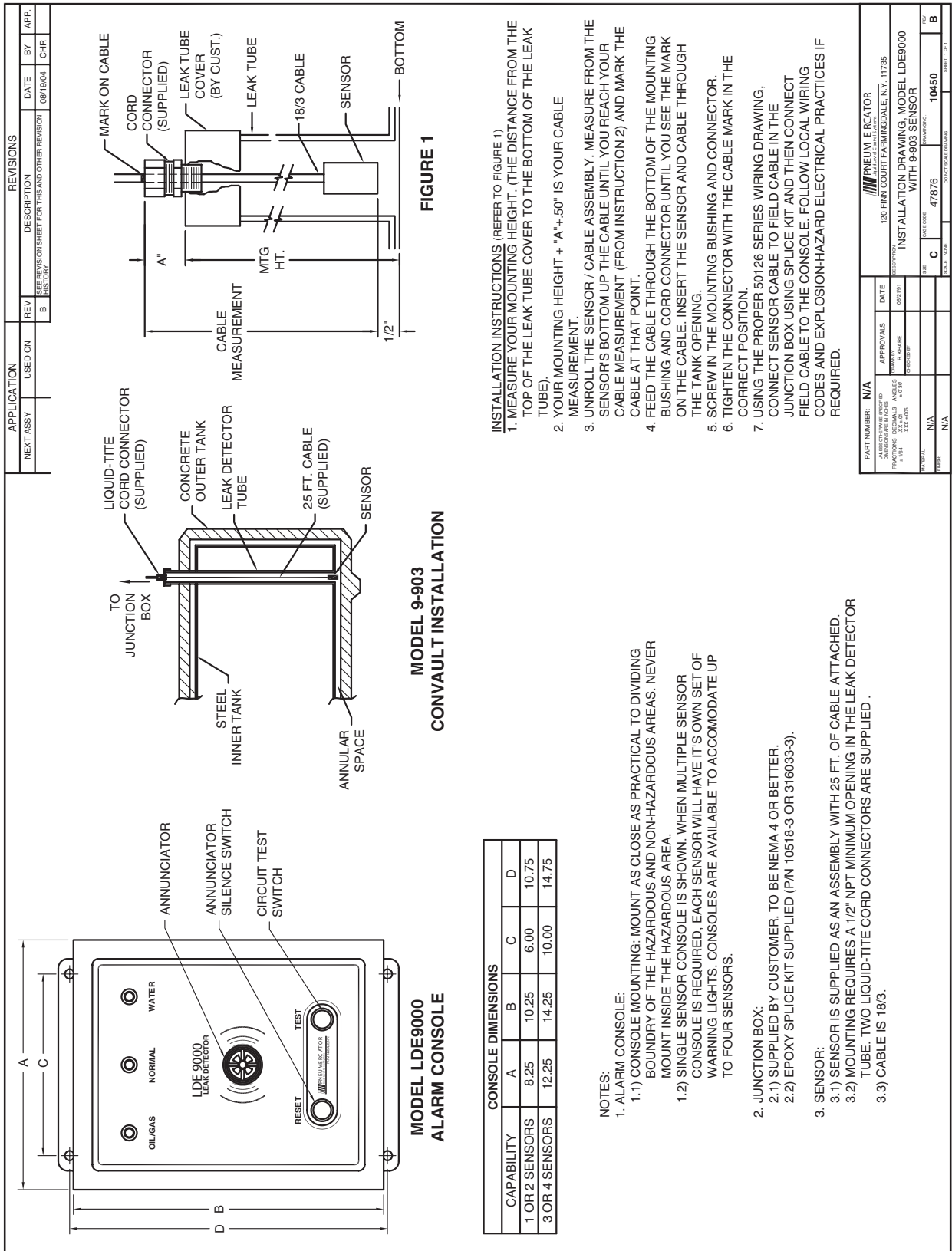

Figure 4 - 9-903 Installation

OPERATION AND INSTALLATION MANUAL

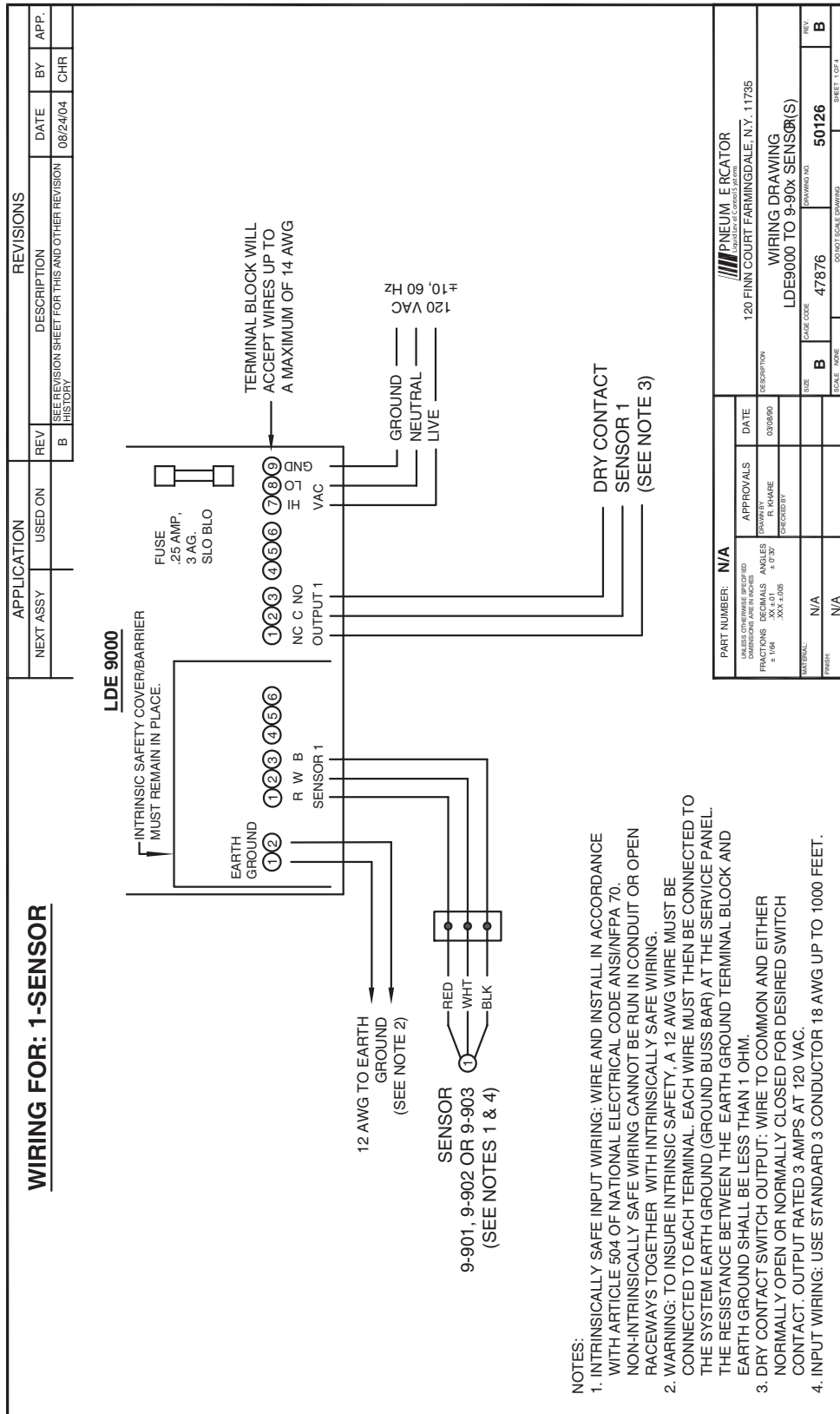

Figure 5 - Wiring Diagram - 1 Sensor

OPERATION AND INSTALLATION MANUAL

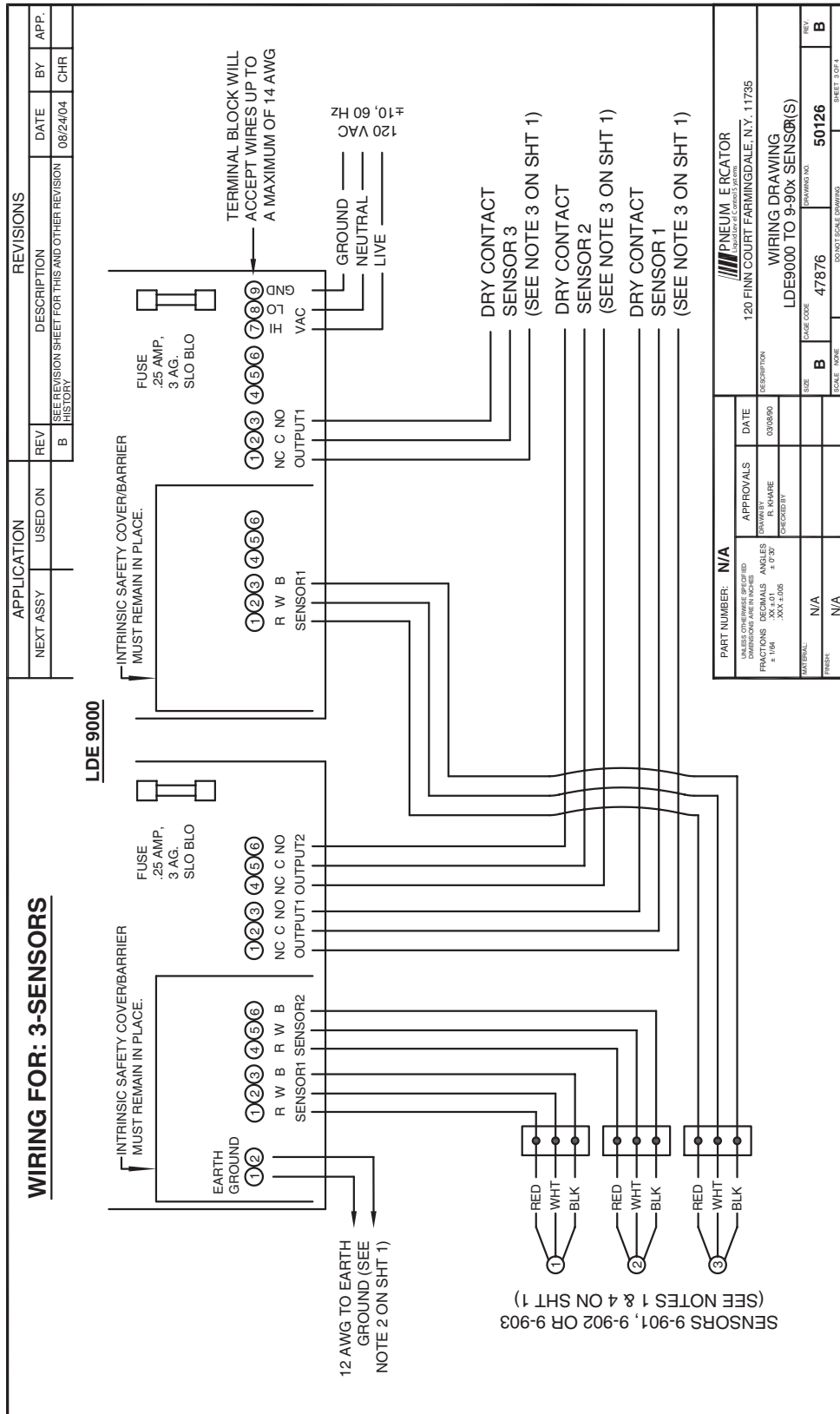

Figure 7 - Wiring Diagram - 3 Sensors

OPERATION AND INSTALLATION MANUAL

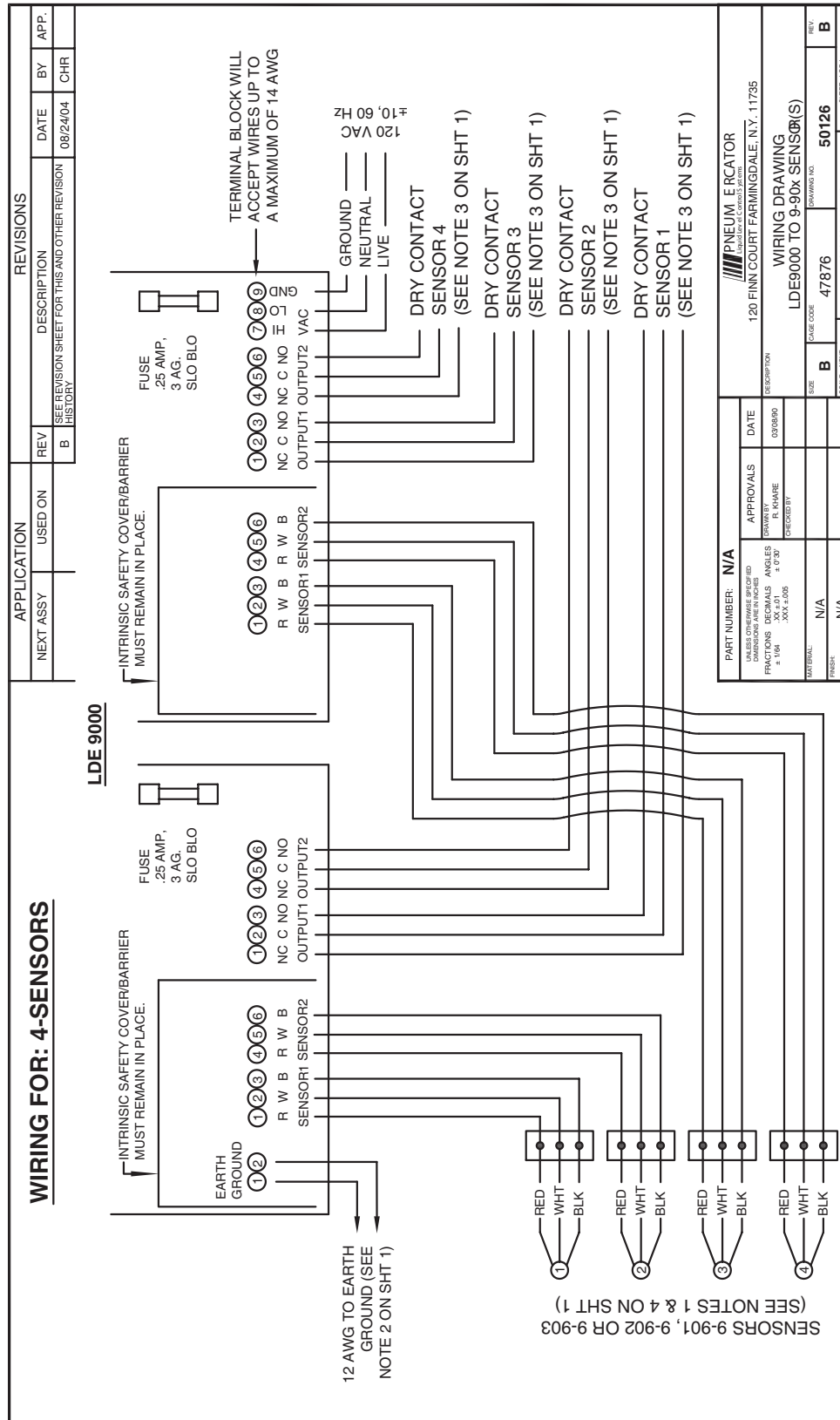

Figure 8 - Wiring Diagram - 4 Sensors

OPERATION AND INSTALLATION MANUAL

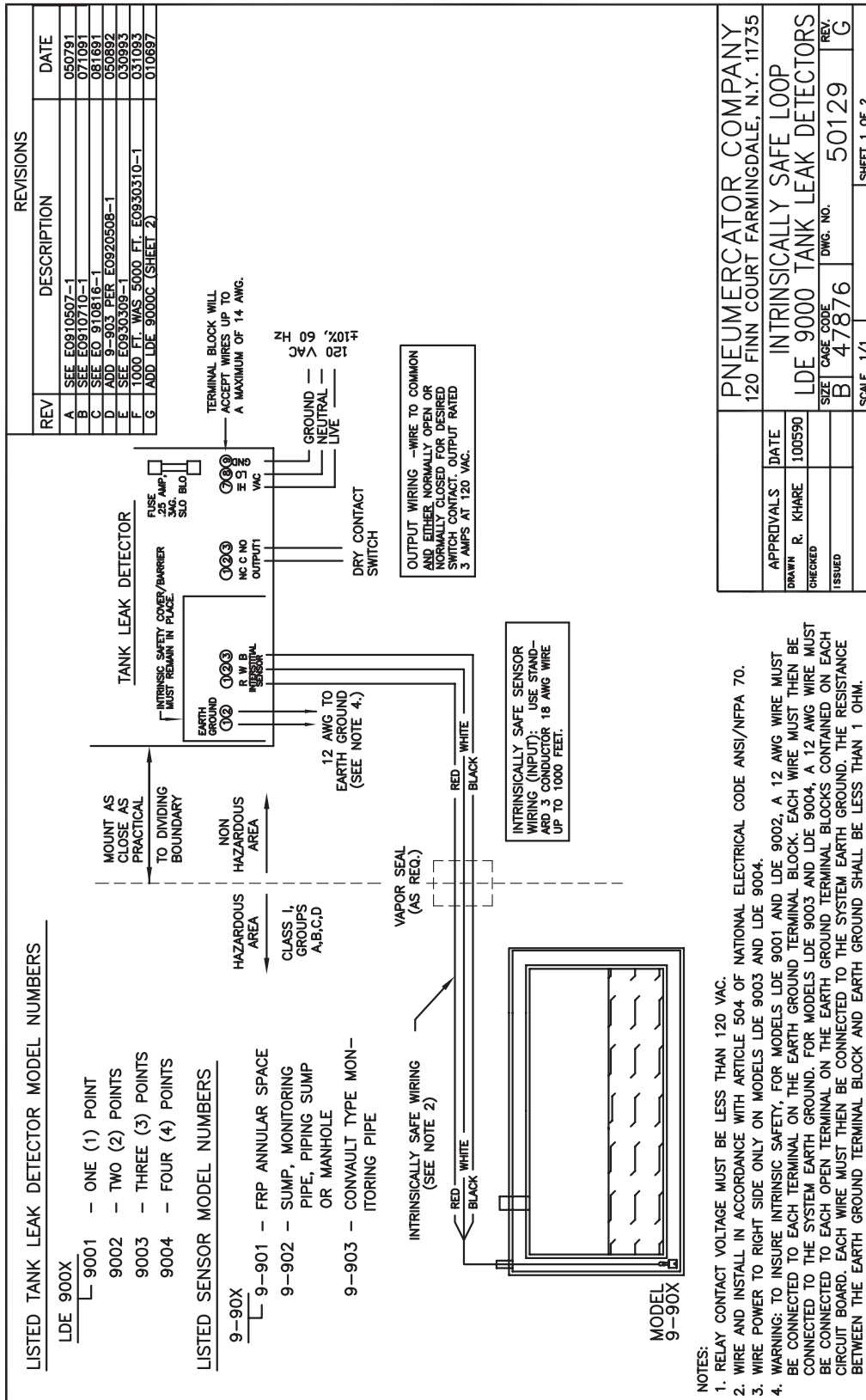

Figure 9 - Intrinsically Safe Loop

OPERATION AND INSTALLATION MANUAL

SPECIFICATIONS

ALARM CONSOLE

Power Input
120 VAC ± 10%, 60 Hz, 30 Watts
Fuse - 1/4 AMP, 3 AG SLO-BLOW

Power to Sensor
5 VDC, Intrinsically safe for Class I, Division 1, Groups A, B, C, D

Hydrocarbon Detection Depth
1/8" typical

Response Time
Less than 1 second

Indicators/Controls
Red light indicates hydrocarbon.
Amber light indicates water.
Green light indicates air (normal).
H-Jorn signals alarm - 85 dB minimum, Adjustable.
Reset button silences horn.
Automatic timed horn available.
Test button tests alarm functions.
Calibrate mode for system set-up and trouble shooting.

Control Relay Output
Dry switch contact-SPDT per sensor.
Field selectable for hydrocarbon or oil/water, rated 3 AMPS at 120 VAC.

Control Enclosure
NEMA-4 weatherproof, wall mount.

Temperature
Sensors: -40°F to 130°F (-40° to 55°C)
Console: -40°F to 122°F (-40° to 50°C)

Weight - Console
8 lbs. (3.6 Kg.) Approx. - Small case
14 lbs. (6.4 Kg.) Approx. - Large case

ALARM CONSOLE MODEL NUMBER SCHEDULE

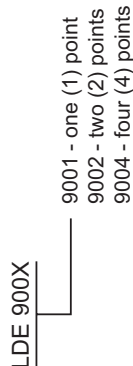

SENSORS

Sensor Cable
Comes with 25 feet/3 conductor 18 AWG.
May be extended up to 500 feet.

Sensor Construction
Epoxy, oil resistant PVC and 316 stainless steel wetted parts, rated to 50 PSI.
Specifications subject to change without notice.

SENSOR MODEL NUMBER SCHEDULE

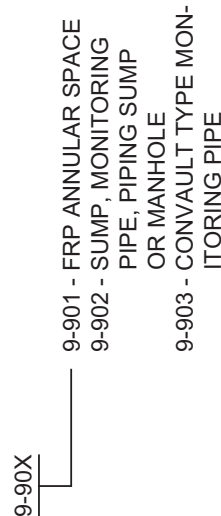

SYSTEM APPROVAL: U.L. APPROVED INTRINSICALLY SAFE FOR CLASS I, DIVISION 1, GROUPS A, B, C, D.

Figure 10 - Specifications

OPERATION AND INSTALLATION MANUAL

CONTROL CONSOLES

MODEL LDE 9001

Sensors: 1
 Console Size: A=10
 B=8
 C=5
 Mounting: D=10.75
 E=6

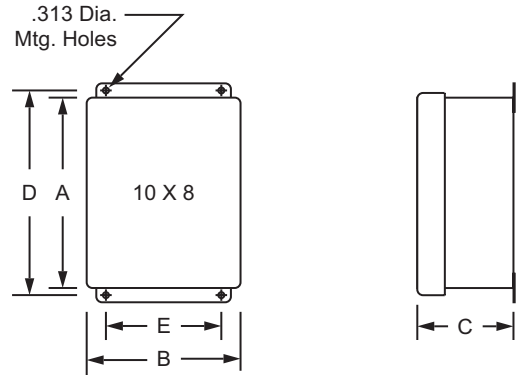

MODEL LDE 9002

Sensors: 2
 Console Size: A=10
 B=8
 C=5
 Mounting: D= 10.75
 E=6

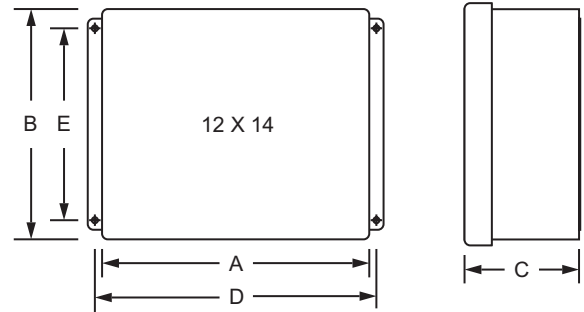

MODEL LDE 9004

Sensors: 3 or 4
 Console Size: A=14
 B=12
 C=6
 Mounting: D=14.75
 E=8

All dimensions in inches

NOTE: 1/2" CONDUIT HOLES PROVIDED ON BOTTOM OF CASE: 1-POWER, 1-EACH TANK.

SENSORS

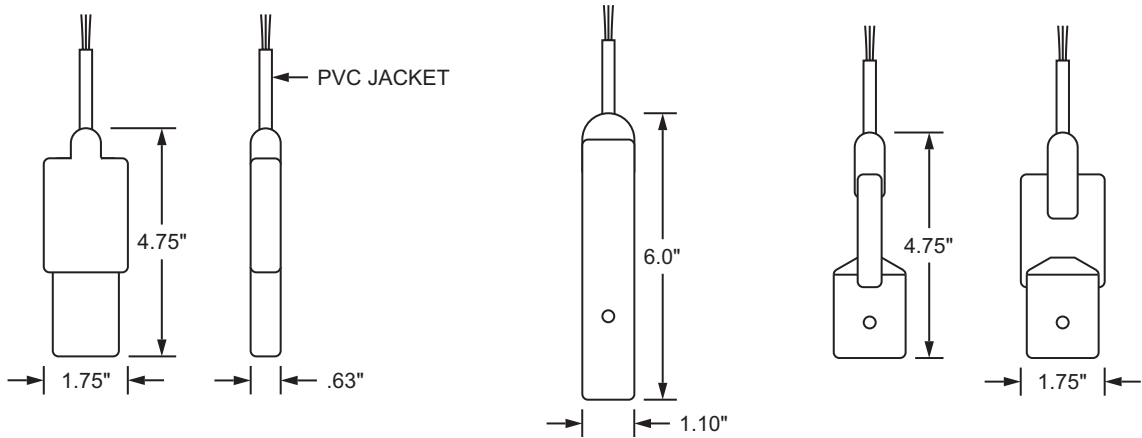

MODEL 9-901

FOR FIBERGLASS DWT
ANNULAR SPACES

MODEL 9-903

FOR CONVAULT TYPE
MONITORING PIPES

MODEL 9-902

FOR MONITORING PIPES
AND PIPING SUMPS

SENSORS ARE SUPPLIED AS AN ASSEMBLY WITH 25 FT. OF 18 AWG WIRE CABLE.

Figure 11 - Dimensions

WARRANTY

We warrant that our leak detection equipment, if installed according to instructions, will be free from defects in material and workmanship for a period of one (1) year following the date of original shipment by us.

Our liability under this warranty shall be limited to, at our option,

- (i) repair of the defective equipment,
- (ii) replacement of the original equipment with new equipment, or
- (iii) refund of the original purchase price; and, we shall not be liable for any labor, other installation costs, indirect or consequential damages, or other damages in connection with such equipment.

This constitutes our obligation and none other stated for any purpose except the above shall apply

rev 051894



Pneumercator Co.
120 Finn Court, Farmingdale, NY 11735
TEL: (631) 293-8450 • FAX: (631) 293-8533
www.pneumercator.com

Distributed by:

--