

INSTRUCTION MANUAL

ETD1000 REMOTE ELECTRONIC TANK DISPLAY

FOR

TMS SERIES TANK MANAGEMENT SYSTEMS

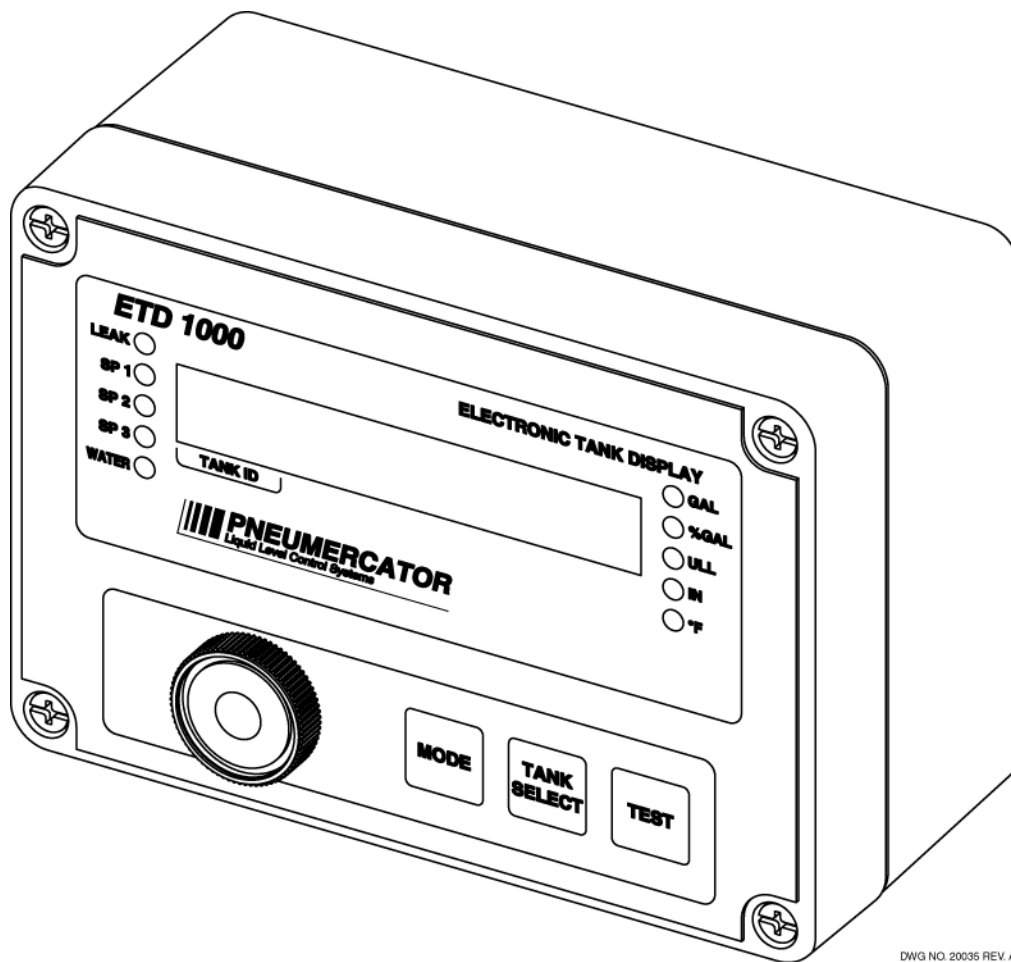

This document describes the installation, programming and operation of the ETD1000 Remote Electronic Tank Display, which is designed for use with any TMS2000 or TMS3000 Tank Management System.

TABLE OF CONTENTS

		Page
Section 1.0	PRODUCT OVERVIEW	1
1.1	TMS Compatibility	2
1.2	Display Data	3
1.3	Display Messages	3
1.4	Alarm LEDs	3
1.5	Audible Annunciator	4
Section 2.0	INSTALLATION.....	5
2.1	Mounting.....	5
2.2	Wiring	8
2.2.1	AC Power	8
2.2.2	Communications.....	9
2.2.2.1	Cable Requirements.....	9
2.2.2.2	ETD1000 Terminal Connections	10
2.2.2.3	ETD1000 Communications Wiring Detail	10
2.2.2.4	TMS Communications Wiring Detail.....	10
2.2.2.5	Line Termination Resistor	12
Section 3.0	CONFIGURATION	13
3.1	On-Board Programming	13
3.1.1	Setting Logical Address - S3	13
3.1.2	Dipswitch Settings - S4	14
3.2	Front Panel Programming	16
3.2.1	Programming Procedure	16
Section 4.0	FRONT PANEL OPERATION - OPERATOR MODE	18
Section 5.0	PRODUCT SPECIFICATIONS.....	19

1.0 Product Overview

The ETD1000 Electronic Tank Display panel is used in applications where it is desired to view TMS series tank management data from various on-site locations at distances up to 4000 feet (1200M) away from the main console. Since the ETD1000 is a microprocessor-based, addressable device communicating over the TMS RS-485 Peripheral Expansion Bus, up to 16 ETD1000 panels may be connected to a single TMS. Unlike the TD1000 Tandem Remote Display, each ETD1000 may be operated independently. The ETD1000 is housed in a NEMA 4X enclosure for harsh industrial/ outdoor environments. The display technology employs an ultra-bright, truly sunlight-readable LED display for maximum reliability in extreme temperatures. The membrane overlay pushbuttons are one inch on centers for easy operation with gloved hands.

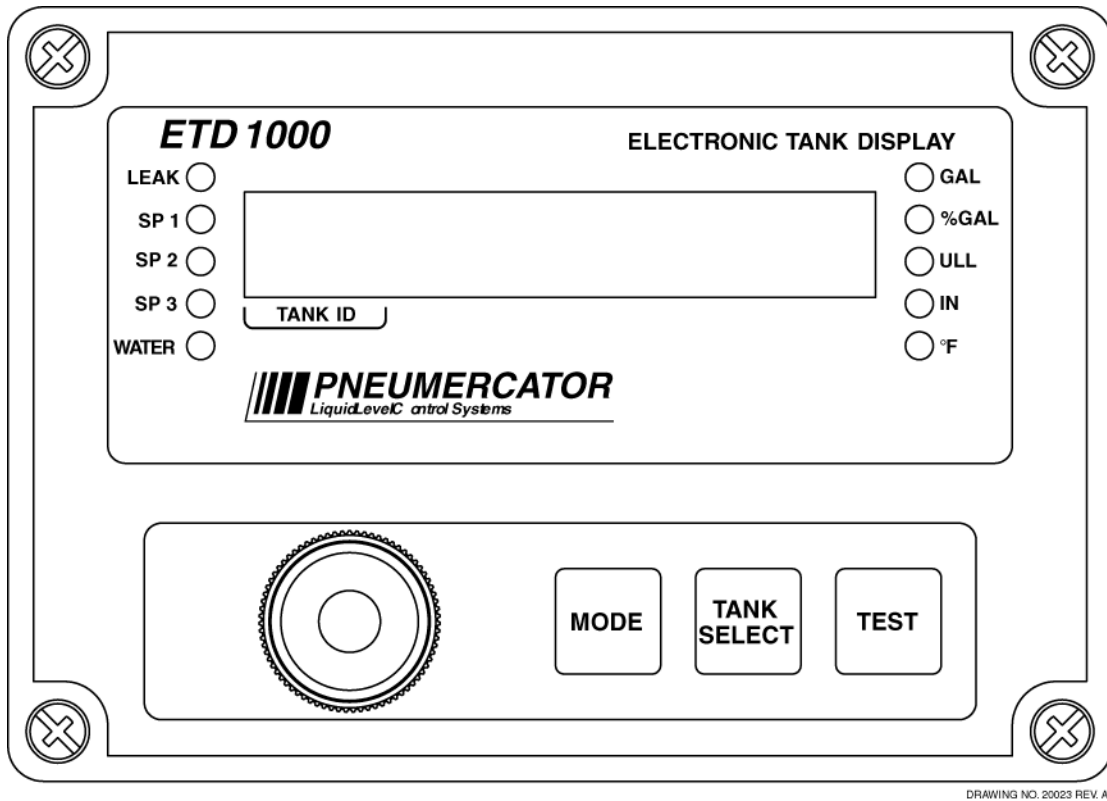

Figure 1.0-1 Front Panel View

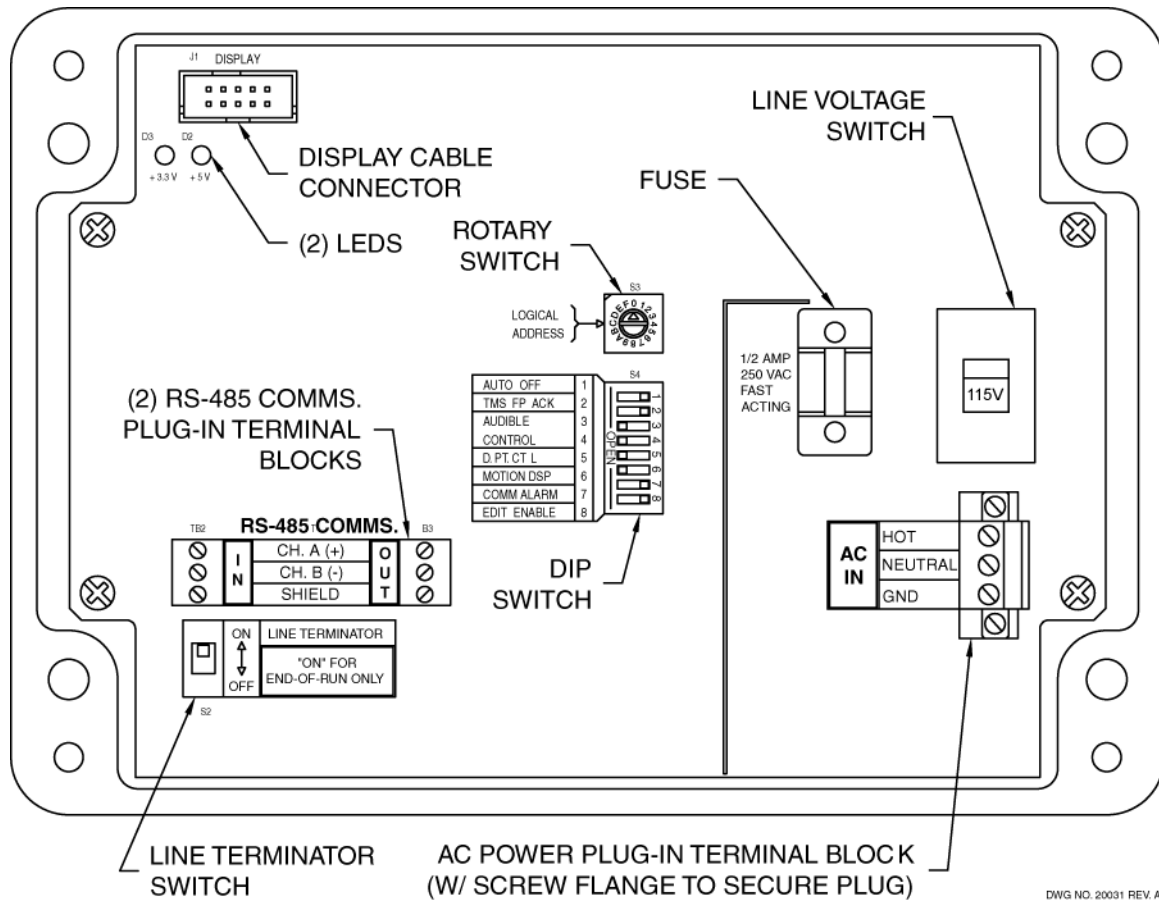

Figure 1.0-2 Interior View

1.1 TMS Compatibility

The ETD1000 can be used with any TMS2000 or TMS3000 provided appropriate firmware is loaded. ETD1000 support is provided with the following TMS console firmware versions;

Vxx.99.90 thru Vxx.99.99
 Vxx.00.xx

where "xx" denotes "don't care" values

Please contact Technical Support for an upgrade if you have firmware outside of the above range, or if you have questions about identifying the TMS firmware version in your console.

IMPORTANT! Confirm that the installed TMS console firmware version supports ETD1000 communications.

1.2 Display Data

The seven-segment LED display shows the selected Tank ID along with the selected tank data as defined in the table below. User-selected tanks and display modes may be enabled or disabled. Refer to Section 3.2 Front Panel Programming for details on this feature.

Display Mode	Data Format*	Display Units
Gallons	DDDDDDDD	Gallons (Liters)
Net Gallons	DDDDDDDD	Gallons (Liters)
Percent Gallons	DDD.d	% of Capacity
Ullage	DDDDDDDD	Gallons (Liters)
Product Level	DDDD.d	Inches (mm)
Water Level	uDDDD.d	Inches (mm)
Product Temperature	sDDD.d	°F (°C)
*Where: d = Tenths, s = Signed Data, u = Water Symbol		

1.3 Display Messages

The seven-segment display indicates a limited number of messages as follows;

Display Message	Description
-No data-	No communications with TMS
nn Lo Prod	Tank level below gaugeable limit
nn -----	Probe timeout or sync error
tank name	User-selected Tank Name
where nn = Tank ID	

The “tank name” message is displayed when the MODE pushbutton is momentarily activated, as described in Section 4.0 ETD1000 Front Panel Operation

1.4 Alarm LEDs

Alarm LEDs are provided to annunciate tank-related alarms as follows;

Alarm LED	Description
Leak	In-Tank Leak Test Failure
SP1	Product Setpoint #1 (HighHigh 95%)
SP2	Product Setpoint #2 (High 90%)
SP3	Product Setpoint #3 (Low 20%)
Water	Water Setpoint
Factory default values in ()	

1.5 Audible Annunciator

A front panel audible annunciator is provided both to annunciate tank or communications alarm conditions, and as an audible confirmation aid when navigating using the membrane pushbuttons. Under alarm conditions, the beep rate of the annunciator varies with the alarm type as follows;

Alarm	Beep Rate
Leak	Fast (50ms)
SP1	Medium Fast (100ms)
SP2	Medium Slow (200ms)
SP3	Slow (400ms)
Water	Slow (400ms)
ms = milliseconds	

2.0 Installation

The ETD1000 is designed for both indoor and outdoor installation. If the unit is to be installed outdoors, the installer must pay attention to local code requirements for outdoor conduit runs containing AC line voltage.

WARNING! This device is designed for Ordinary Location, Non-Hazardous installation only, as defined by Underwriters Laboratories (UL) and the National Electrical Code (NEC). DO NOT install where flammable vapors may be present.

2.1 Mounting

The ETD1000 is designed for wall mounting using the four mounting holes as shown in Figure 2.1-1. Mounting hole placement is made easy using supplied 1:1 scale mounting template in Figure 2.1-2. Note that these mounting holes are outside of the gasketed interior of the enclosure and therefore do not affect weatherproof performance.

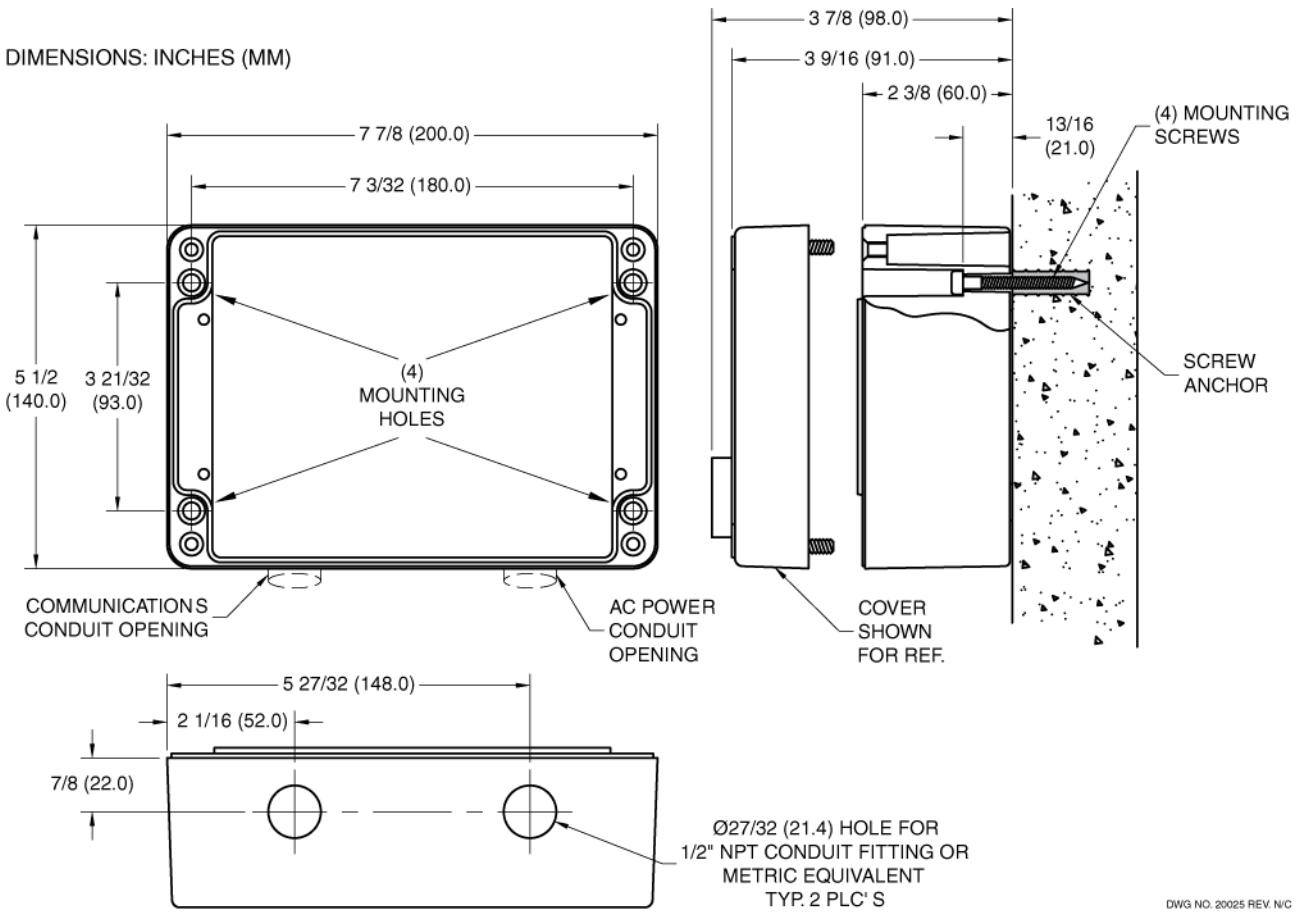

Figure 2.1-1

DIMENSIONS: INCHES (MM)

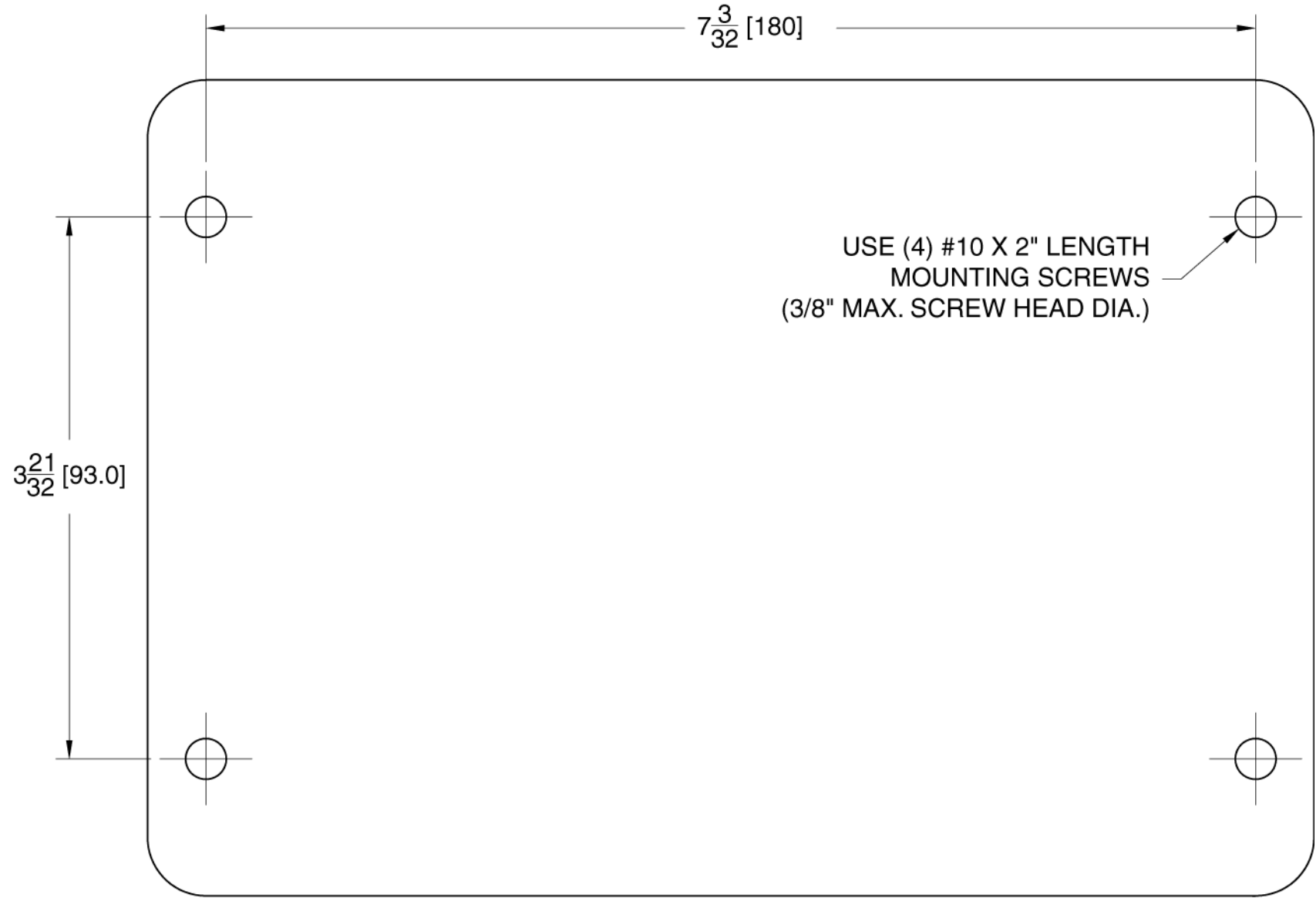

Figure 2.1-2 Mounting Template

DWG NO. 20024 REV. N/C

2.2 Wiring

2.2.1 AC Power

DANGER! AC power must be turned off at the circuit breaker before attempting to connect AC wiring to this device.

WARNING! Do not connect or disconnect front panel display cable while AC power is applied. Damage to display or main board may occur!

Wire AC power in accordance with Figure 2.2.1-1 below. Be sure to set 115/230VAC selector switch to the proper voltage. Note that the AC terminal block can be wired in-place or unplugged.

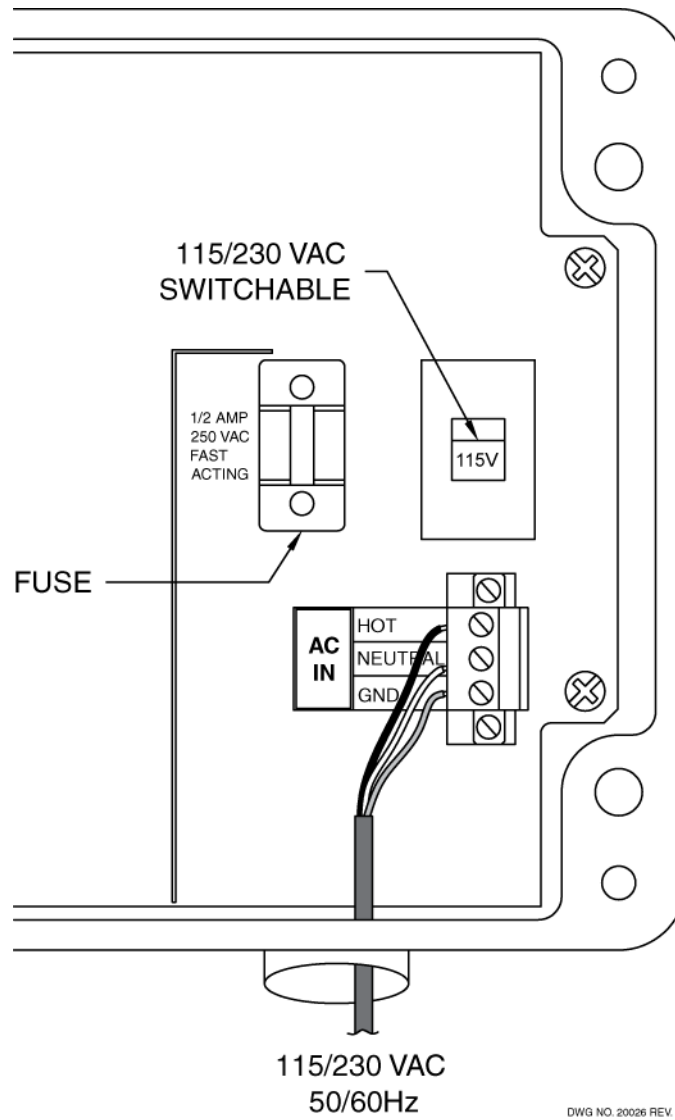

Figure 2.2.1-1

2.2.2 Communications

The ETD1000 supports an RS-485 multi-drop cabling topology as illustrated in Figure 2.2.2-1 below. Maximum cable distance from the TMS console to the furthest ETD1000 is 4000 feet (1200M).

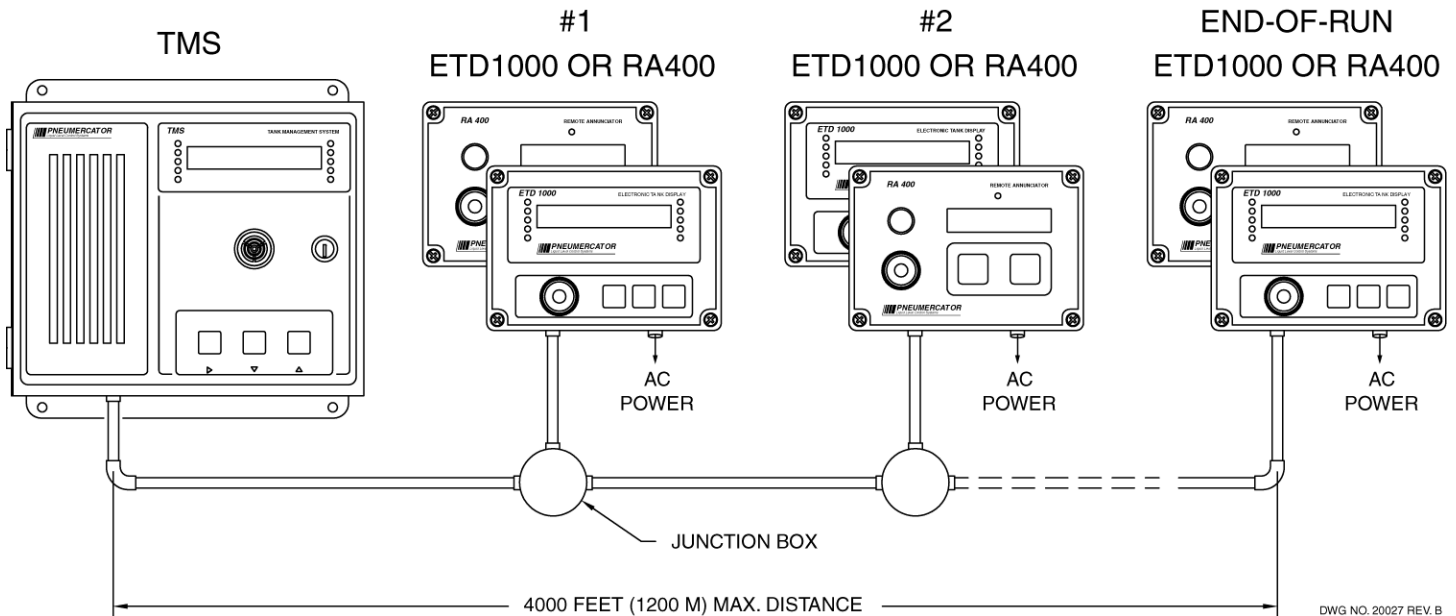

Figure 2.2.2-1 Communications Topology

2.2.2.1 Cable Requirements

Cable type should be 24AWG, single twisted pair, shielded, designated for RS-485 communications having a nominal impedance of 120 ohms.

Recommended Cables:

- 4° to 176°F (-20° to 80°C) Operation* - Belden 9841 or equivalent
- 94° to 392°F (-70° to 200°C) Operation* - Belden 89841 or equivalent

*See Section 5.0 Product Specifications for Operating Temperature range limits of the ETD1000.

IMPORTANT! Use only recommended RS-485 communications cable or manufacturer's DOCUMENTED equivalent.

2.2.2.2 ETD1000 Terminal Connections

Plug-in terminal blocks TB2 and TB3 are provided for connection to the RS-485 TMS Expansion Bus. Both input and output terminals are provided to support multi-drop wiring to additional ETD1000s or other TMS expansion bus peripherals.

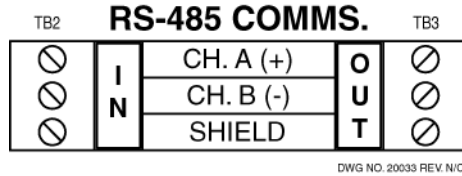

2.2.2.3 ETD1000 Communications Wiring Detail

See Figure 2.2.2.3-1 below.

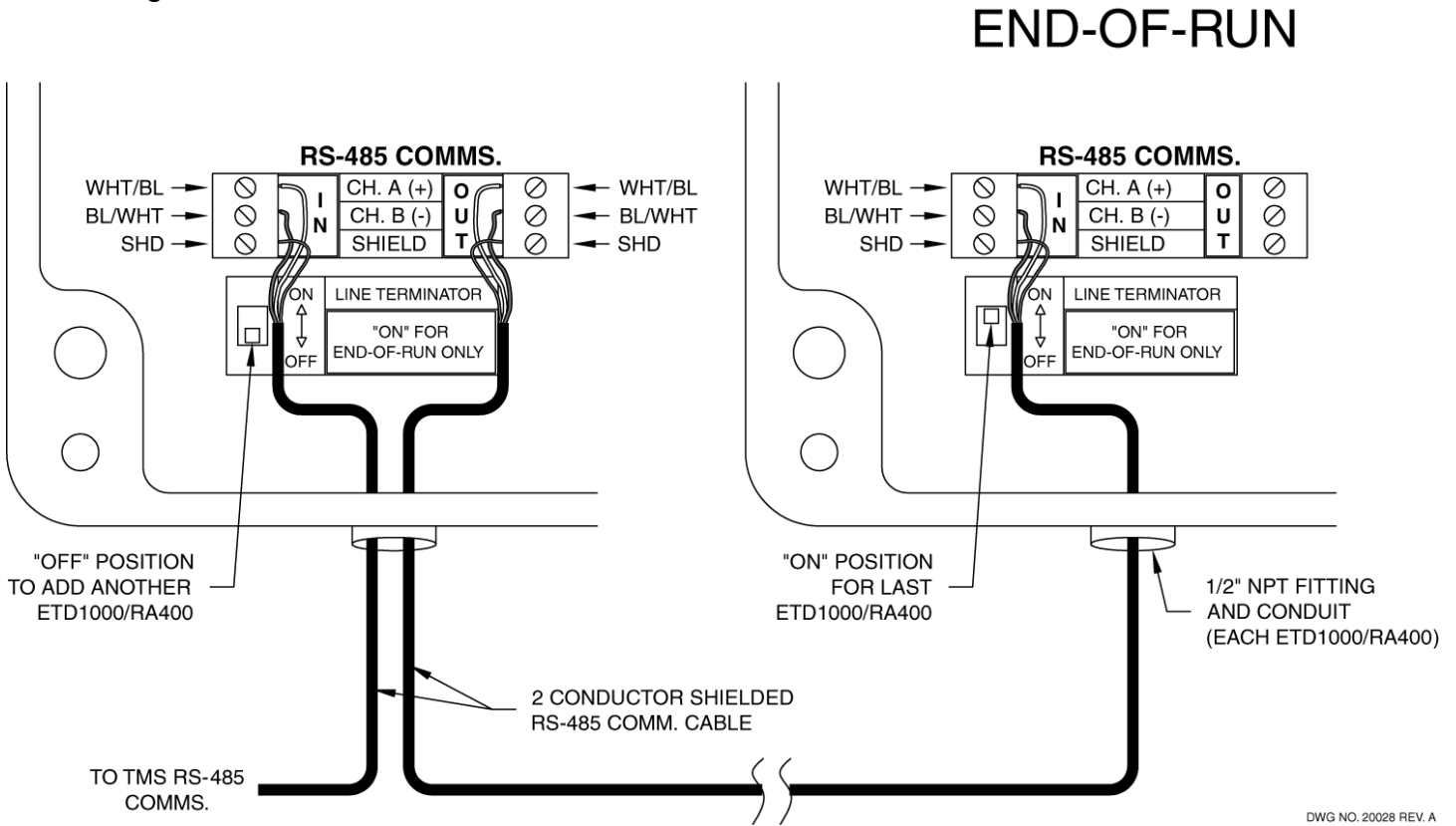

Figure 2.2.2.3-1 ETD1000 Communications Wiring

2.2.2.4 TMS Communications Wiring Detail

Current version TMS2000 and TMS3000 consoles have the same type of plug-in terminal connector and wiring designations as the ETD1000, as illustrated in Figure 2.2.2.4-1 below. Previous versions have a 6-pin modular jack, as illustrated in Figure 2.2.2.4-2 below. If the board type is a previous version and was indicated on the order to the factory, the ETD1000 is shipped with a modular-jack-to-terminal-connector adapter, also shown in Figure 2.2.2.4-2.

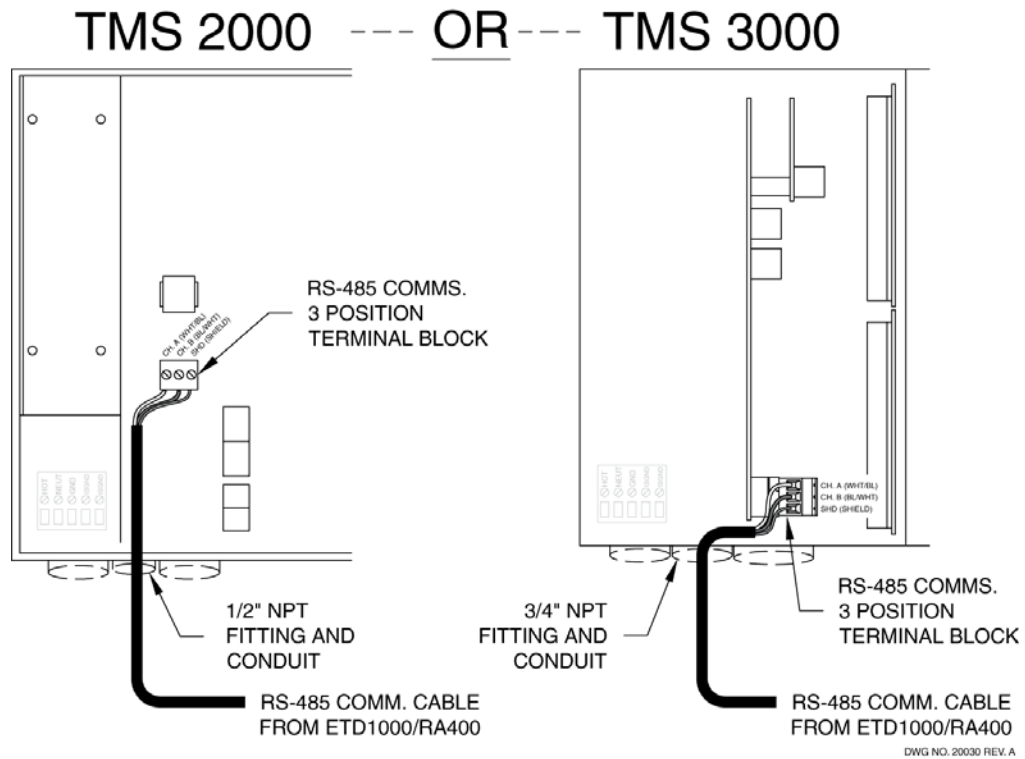

Figure 2.2.2.4-1 TMS Communications Connection, Current Version Boards

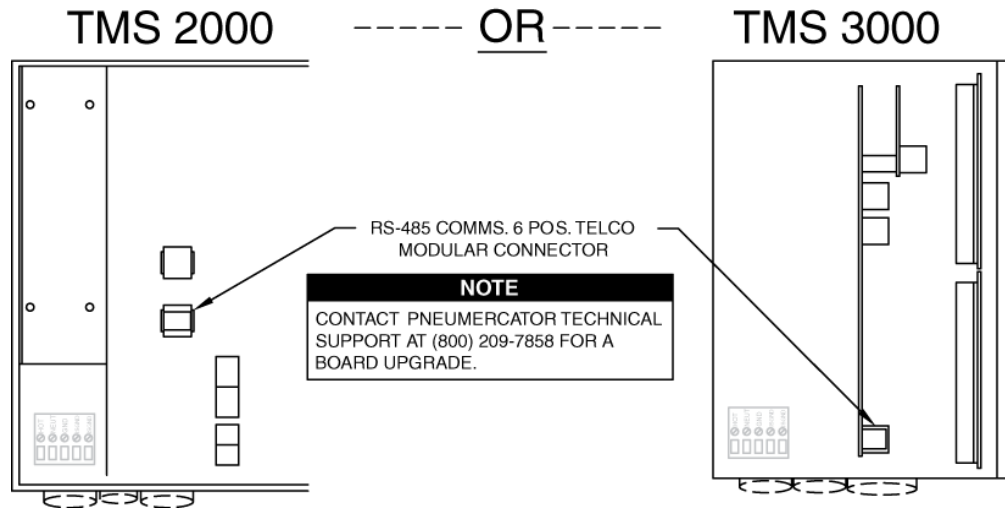
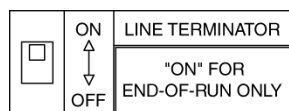

Figure 2.2.2.4-2 TMS Communications Connection, Previous Version Boards

2.2.2.5 Line Termination Resistor

The RS-485 bus requires that the end-of-run device be terminated with a 120-ohm resistor. This is accomplished by setting the LINE TERMINATION switch to "ON" if the selected ETD1000 is the last device on the bus. Otherwise this switch should be set to "OFF".



S2

DWG NO. 20034 REV. A

3.0 Configuration

The ETD1000 provides user-programmable features that allow the operator to alter display and audible alarm operation as well as control interaction with the TMS for remote alarm acknowledgement. Some of these programmable features are available through the front panel pushbuttons, others via on-board dialswitches. No programming is required at the TMS console.

3.1 On-Board Programming

3.1.1 Setting Logical Address – S3

The TMS series console has the ability to individually address up to sixteen (16) ETD1000 remote displays. Rotary dipswitch S3 is used to select unique addresses for each ETD1000 connected to the same TMS. Note that address order is not important.

Table 3.1.1-1 S3 Assignments

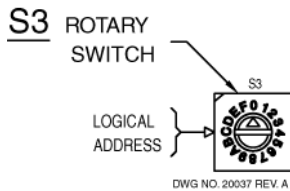

S3 Address Select	ETD1000 Device Address
0	1
1	2
2	3
3	4
4	5
5	6
6	7
7	8
8	9
9	10
A	11
B	12
C	13
D	14
E	15
F	16

3.1.2 Dipswitch Settings – S4

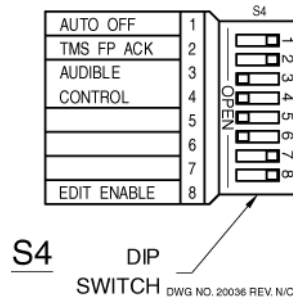

Audible Shutoff Delay: If set to NONE, audible alarm will continue until acknowledged on front panel pushbuttons. If set to ONE MINUTE, audible alarm will continue until acknowledged on front panel pushbuttons or one minute has elapsed, whichever comes first.

Front Panel (FP) Acknowledge Settings: If set to LOCAL, front panel acknowledgement will only silence local ETD1000 audible alarm. If set to LOCAL and TMS, both ETD1000 and TMS audible alarms will be silenced.

Audible Alarm Mode: If DISABLED, audible will not activate for any condition. If set to DISPLAYED TANK ONLY, audible alarm will activate only if unacknowledged alarms apply to the currently displayed tank. If set to ALL TANKS, audible alarm will activate for unacknowledged alarms from any enabled tank.

Decimal Point Control: This setting controls placement of decimal points for U.S. and METRIC units of measure. It does not perform conversions. This switch should be set to correspond to the TMS units of measure and the overlay insert on the ETD1000 front panel.

Motion Symbol Display: The MOTION symbol “_” appears directly to the right of the tank ID to indicate movement of product in the displayed tank. This status is detected by the TMS and sent to the ETD1000 for display, if enabled. Refer to the TMS Operations Manual for more information.

Loss of Communications Alarm: When ENABLED, an audible alarm accompanies the “No data” message if communications between the TMS and ETD1000 has failed for more than 10 seconds.

Front Panel Configuration Edit: This switch must be set to ENABLE if front panel programming is required. Once programming is complete, the user can DISABLE editing and close the ETD1000, thereby reducing the possibility of unauthorized changes.

Table 3.1.2-1 S4 Assignments

Function	S4 Position(s)	Mode
Audible Shutoff Delay	1	*Closed = NONE Open = ONE MINUTE
Front Panel Ack.	2	*Closed = LOCAL Open = LOCAL and TMS
Audible Alarm Mode	3,4	3 Closed, 4 Closed = DISABLED 3 Open, 4 Closed = DISPLAYED TANK ONLY 3 Closed, 4 Open = ALL TANKS *3 Open, 4 Open = ALL TANKS
Decimal Pt. Control	5	*Open = U.S. Closed = METRIC
Motion Symbol “_” Display	6	*Open = DISABLE Closed = ENABLE
Audible Alarm for Loss of Communications	7	*Closed = DISABLE Open = ENABLE
Front Panel Configuration Edit	8	*Closed = DISABLE Open = ENABLE

*Factory Default

3.2 Front Panel Programming

Front panel programming allows the user to specify which tanks, alarms and display modes, i.e. gallons, inches, etc., are to be made available to the operator. For example, a user could limit the operator to display a single tank in a multi-tank system, limit alarms to selected setpoints, and further limit the operator to a single mode of display, for example, gallons only. The ETD1000 is shipped from the factory with all available tanks, alarms and display modes enabled. Note that tanks that are not enabled on the TMS are automatically disabled on the ETD1000 and therefore do not require any programming to disable them. For security purposes, an on-board dipswitch is provided to enable or disable front panel programming. See Section 3.1 for details. Programmed settings are stored in non-volatile memory that requires no batteries, and therefore will remain intact indefinitely with or without AC power.

3.2.1 Programming Procedure

REMINDER: Dipswitch S4-8 must be set to ENABLE for front panel programming. See Section 3.1 for details.

- 1) While first pressing and holding TEST, press and hold MODE.
- 2) The message Tank Enabl (Tank Enable Menu) should appear after approximately two (2) seconds. Release both pushbuttons.
- 3) The display should automatically change to display Tank #1 in the Tank ID field with the enable displayed as "YES" or "NO". Refer to Table 3.2.1-1 Front Panel Programming below.
- 4) The Tank Enable setting "YES" or "NO" can be toggled with the TEST pushbutton.
- 5) Advance to the next tank by pressing TANK SELECT. Pressing and holding TANK SELECT will cause the display to continually advance.
- 6) Repeat steps 4 and 5 until all tank enables are completed.
- 7) The message Mode Enabl (Display Mode Enable Menu) will appear for approximately two (2) seconds, then change to display the first display mode LED, GAL(LT) with the enable displayed as "YES" or "NO". Refer to Table 3.2.1-1 Front Panel Programming below.
- 8) The Display Mode Enable setting "YES" or "NO" can be toggled with the TEST pushbutton.
- 9) Advance to the next display mode by pressing MODE. Pressing and holding MODE will cause the display to continually advance.
- 10) Repeat steps 8 and 9 until all display mode enables are completed.
- 11) The message Alrm Enbl (Alarm Enable Menu) will appear for approximately two (2) seconds, then change to display the first alarm mode LED, LEAK with the enable displayed as "YES" or "NO". Refer to Table 3.2.1-1 Front Panel Programming below.
- 12) The Alarm Enable setting "YES" or "NO" can be toggled with the TEST pushbutton.
- 13) Advance to the next alarm mode by pressing MODE. Pressing and holding MODE will cause the display to continually advance.
- 14) Repeat steps 12 and 13 until all alarm enables are completed.
- 15) The new settings will be saved and the ETD1000 will automatically return to normal viewing mode.

Table 3.2.1-1 Front Panel Programming

Display Function	Mode
Tank #1 Enable	*YES/NO
Tank #2 Enable	*YES/NO
Tank #3 Enable	*YES/NO
Tank #4 Enable	*YES/NO
Tank #5 Enable	*YES/NO
Tank #6 Enable	*YES/NO
Tank #7 Enable	*YES/NO
Tank #8 Enable	*YES/NO
Tank #9 Enable	*YES/NO
Tank #10 Enable	*YES/NO
Tank #11 Enable	*YES/NO
Tank #12 Enable	*YES/NO
Gross Volume Enable	*YES/NO
Net Volume Enable	*YES/NO
Percent Volume Enable	*YES/NO
Ullage Enable	*YES/NO
Product Level Enable	*YES/NO
Water Level Enable	*YES/NO
Product Temperature Enable	*YES/NO
In-Tank Leak Alarm Enable	*YES/NO
SP1 Alarm Enable	*YES/NO
SP2 Alarm Enable	*YES/NO
SP3 Alarm Enable	*YES/NO
Water Alarm Enable	*YES/NO

*Factory Default

4.0 Front Panel Operation – Operator Mode

<u>Alarm LEDs*</u>	
● LEAK	– In-Tank Leak
● SP1	– Above 95% (High High)**
● SP2	– Above 90% (High)**
● SP3	– Below 20% (Low)**
● WATER	– Above 2"***

<u>Display Mode LEDs</u>	
● GAL	– Gross Volume (Gal/Ltr) Net Volume (with °F/ C LED on)
● %GAL	– Percent of Capacity
● ULL	– Ullage Vol (Gal/Ltr, Default 90%)
● IN	– Product Level (in/mm) Water Level (with “u” symbol, in/mm)
● °F	– Product Temperature (°F/ C)

Audible Alarm Acknowledgment

To silence an alarm, press any of the buttons. The visual indicator will remain active as long as the alarm condition persists.



Front Panel Buttons

MODE

Press to display tank name.
Press and hold until beep
to select display mode

TANK SELECT

Press to select tank
Press and hold until
beep for tank autoscan

TEST

Press to test
display and
horn

* If an alarm LED is blinking, an active tank alarm is present on a tank(s) not currently being displayed. When an alarm LED is on continuously, it applies to the currently displayed tank. Note that this alarm may apply to more than one tank, which can be determined by viewing each tank with the TANK SELECT button.

** TMS console factory defaults shown. The TMS may be programmed to other values.

5.0 Product Specifications

Dimensions: 7.9" W x 5.5"H x 3.5"D

Weight: 8 lbs

Operating Temperature: -40° to +160° F (-40° to +70° C)

Humidity: 95% Non-condensing

Enclosure Construction: Cast Aluminum, Epoxy Powder Coat Paint Finish, Gasketed Cover w/Captive SS Screws

Enclosure Rating: NEMA 4X, Watertight and Corrosion-proof

Power Requirements: 115 / 230 VAC Switchable, 50-60Hz, 5W Max.

Audible Alarm: 100db

Display: 9-Character, Ultra-Bright Sunlight-Readable LED Display, 0.56" Ht, Readable from 25'
Ultra-Bright Intensity Alarm LEDS, Visible from 75'

Display Data: Gross/Net Volumes, Percent Volume, Ullage, Product Level, Water Level, Product Temperature, Tank Name, Tank ID, Tank Alarms

LED Display Mode Indicators: Volume, Percent Volume, Ullage, Product Height, Water Height, Product Temperature

LED Alarm Indicators: In-Tank Leak, Three Product Setpoints, Water Setpoint

Communications: TMS Series Peripheral Expansion Bus

Communications Format: RS-485, Half-Duplex

Connection Type: Plug-In Terminal Block with Wire Entries

Input: Ch. A (+), Ch. B (-), Shield

Output: Ch. A (+), Ch. B (-), Shield

Recommended RS-485 Cable: Belden 9841 (PVC Jacket), 89841 (FEP Teflon Jacket) or similar

Maximum Cable Length: 4000 Feet/1200 Meters total to end of run

Slave Address Select: 1 thru 16, Rotary Dip Switch Selectable

Display Update Rate from TMS: 400 to 600 milliseconds (0.4 to 0.6 seconds)

