

# INSTRUCTION MANUAL

Revised: November 24, 2004

## E-Series

E-14/E-29

E-14-1/E-29-1

LCE-14/LCE-29

---

© COPYRIGHT 2004 PNEUMERCATOR CO.  
120 FINN COURT, FARMINGDALE, N.Y. 11735  
(631) 293-8450 Phone  
(631) 293-8533 Fax  
(800) 209-7858 Product Support  
[www.pneumercator.com](http://www.pneumercator.com)

## PREFACE

NOTICE: PNEUMERCATOR CO., INC. reserves the right to make improvements to the product described in these instructions at any time and with no notice.

IMPORTANT: Installation of this equipment must be in accordance with these instructions as adopted from the following codes:

ISA RP12.6, "Installation of Intrinsically Safe Instrument Systems in Class I Hazardous Locations".

NFPA 70, "National Electrical Code".

Alteration, modification or replacement with non-factory components could impair the intrinsic safety of this equipment.

**OPERATION AND INSTALLATION MANUAL**

---

## Table of Contents

Preface

Section 1: Introduction	1
Section 2: Specifications	3
Section 3: Installation	4
Section 3.1: Mechanical Installation	4
Section 3.2: Transmitter/Sensor Installation	5
Section 3.2.1: Tank Transmitters	5
Section 3.2.2: Switch Sensor	5
Section 3.3: Electrical Installation	6
Section 3.4: Installation Checklist	7
Section 4: Operation	8
Section 4.1: Normal Operation	8
Section 4.2: The Horn	8
Section 4.3: The Relay Contacts and Alarm Settings	8
Section 4.4: The Simulator	10
Section 4.5: Calibrating Alarm Settings	10
Section 4.6: 4 to 20 mA Output	11
Section 4.7: Switch Inputs	11
Section 4.8: Master-Slave Option	11
Section 5: Troubleshooting & Servicing	12
Section 6: Circuit Board Part Numbers	15
Figure 1: Relay Card Settings	10
Figure 2: 2-412 Installation	16
Figure 3: 2-501 Installation	18
Figure 4: Main Circuit Board Layout	20
Figure 5: Indicator Circuit Board Layout	21
Figure 6: Relay Circuit Board Layout	22
Figure 7: 4 to 20 mA Circuit Board Layout	23
Figure 8: System Wiring Diagram	24

Warranty

## OPERATION AND INSTALLATION MANUAL

---

### Section 1 Introduction

The PNEUMERCATOR E-14 and E-29 are advanced inventory management and control systems. Drawing upon PNEUMERCATOR's more than 85 years of experience in liquid level controls and measurement systems, the E-14 and E-29 are designed to help simplify the inventory process, and to be extremely easy to operate.

The E-14 offers a 14.5" dial and the E-29 offers a 29.5" dial that constantly indicate the product level in a liquid storage tank. Optional High (overflow) and Low level lights, alarm contacts, horn and reset button, slave display, switch input and 4 to 20 mA output signal complete a level control system that provides all the features needed to comply and compete in today's market.

The E-14 and E-29 easily accommodate different sizes of underground and aboveground storage tanks, and are suitable for all types of fluids. Some of the fluids that are suitable for monitoring with the E-14 and E-29 are petroleum products, waste oil, conductive and non-conductive fluids, water, alcohols, solvents, lubricants, and corrosive chemicals. The systems offer conversion of level to volume pre-calibrated to match the geometry of the storage tank used. PNEUMERCATOR's many years of experience help guarantee an accurate conversion of height to gallons for all types and configurations of storage tanks.

The system console may be mounted in any non-hazardous area where it can be provided with 120 VAC  $\pm 10\%$  at 60 Hz. The standard enclosure is NEMA 12, with a NEMA 4 console optionally available.

The system transmitters and sensors are designed for intrinsically safe operation in Class I, Division 1, Group A, B, C, D areas. The transmitters may be separated from the console by 3-wire 18 AWG runs of up to 5000 feet. Switch sensors may be separated from the console by 2-wire 18 AWG runs of up to 5000 feet.

The system is designed to provide safe and reliable operation when installed as instructed in the Installation section of this manual. All requirements of the National Electrical Code (NEC) as well as local electrical and fire codes should be followed in the installation procedures. It is recommended that the user should read and understand ANSI/ISA RP12.6, "Installation of Intrinsically Safe Instrument Systems in Class I Hazardous Locations".

## OPERATION AND INSTALLATION MANUAL

---

If additional information is needed concerning equipment selection, system planning, installation, operation, or servicing or maintenance, please contact:

PNEUMERCATOR CO., INC.  
120 Finn Court  
Farmingdale, NY 11735  
(631) 293-8450 Phone  
(631) 293-8533 Fax  
(800) 209-7858 Product Support  
[www.pneumercator.com](http://www.pneumercator.com)

## OPERATION AND INSTALLATION MANUAL

---

### Section 2: Specifications

Power - 120 VAC  $\pm$ 10%, 60 hertz, 13 Watts, MOV surge protection.

Fuse - 3 A.G. SLO-BLO, 1/2 Amp, 250 VAC or equivalent.

Operating Temperature - -40 °F to 122 °F (-40 °C to 50 °C).

Enclosure - NEMA 12 standard, NEMA 4 optional.

Installation - Wall mount.

Gauging Accuracy -  $\pm$ 1.50% of tank height or  $\pm$ 1/8" w/2-412 or  $\pm$ 1/4" w/2-501, whichever is greatest.

Horn - Min. 85 dB at 3 meters on axis, manual horn reset (silence) pushbutton.

Relay Outputs - Up to 4 SPDT dry relay contacts, rated at 5 Amps at 120 VAC.

Gauging Transmitter - Standard: 2-412 or 2-501. Intrinsically safe for Class I, Division 1, Groups A, B, C, D, 12 VDC @31 mA.

Switch Input - 1 (optional) from any mechanical switch input. Intrinsically safe for Class I, Division 1, Groups A, B, C, D, 12 VDC @31 mA.

Output Signals - Optional 4 to 20 mA non-isolated output, 500 $\Omega$  max. load.

Transmitter/Sensor Operating Temperature -  
2-412, 2-501 Transmitters: -20 °F to 180 °F (-29 °C to 82 °C).  
LS-600 Switch Sensors: -20 °F to 180 °F (-29 °C to 82 °C).  
LS-600LD Leak Sensors: -40 °F to 160 °F (-40 °C to 71 °C).

Transmitter/Sensor Operating Pressure -  
2-412 Transmitter: to 50 psi.  
2-501 Transmitter: to 15 psi.  
LS-600 Switch Sensors: to 150 psi.  
LS-600LD Leak Sensors: to 100 psi.

Transmitter/Sensor Cable -  
2-412, 2-501 Transmitters: Standard 3-conductor 18 AWG, up to 5000 feet.  
Switch sensors: Standard 2-conductor 18 AWG, up to 5000 feet.

## OPERATION AND INSTALLATION MANUAL

---

### Section 3: Installation

NOTE: INSTALLATION MUST BE DONE BY QUALIFIED PERSONNEL, FAMILIAR WITH LOCAL WIRING CODES AND EXPLOSION HAZARD ELECTRICAL SAFETY PRACTICES.

#### Section 3.1: Mechanical Installation

The E-14 or E-29 standard console is a NEMA 12 enclosure. An optional NEMA 4 enclosure intended for indoor or outdoor installation is available and offers protection against splashing water, seepage of water, falling of hose directed water, and severe external condensation. The NEMA 4 enclosure is also sleet resistant. Either enclosure has mounting flanges, which allow permanent fastening to walls, panels, etc.

The console should be located in an area that is easily accessible to the personnel responsible for operating the system. This is to allow easy maintenance access, and access to the console for operation and testing. The console must be located in a non-hazardous area, as close as possible to the demarcation point of the hazardous area, with available 120 VAC power brought to the console through a dedicated metal wiring conduit. The metal conduits for transmitters/sensors and power should be weathertight. Bottom entrance holes are provided for 3/4" NPT pipe or rigid metal conduit, with transmitters/sensors entering on the bottom left and power entering on the bottom right.

Consult the local electrical codes for specific requirements.

## OPERATION AND INSTALLATION MANUAL

---

### Section 3.2: Transmitter/Sensor Installation

#### Section 3.2.1: Tank Transmitters

There are two tank-gauging transmitters available for the E-14 and E-29. The model 2-412 is designed for installation in 4" minimum tank openings. The model 2-501 is designed for installation in 2" minimum tank openings and is designed for use with heavy viscous fluids like #6 oil.

Three (3) 18 AWG wires are required for the model 2-412 and model 2-501 transmitters. The wiring should be run through NEMA 4 or better junction boxes and 3/4" weatherproof liquid tight metal conduit. The metal conduit and junction boxes should be sealed against entry of water. If required, vapor seals may be installed to prevent gas vapors from propagating back to the console. The transmitter wiring to the console should be run in a dedicated metal wiring conduit. No non-intrinsically safe wires should be in the same conduit unless a metal barrier is provided.

The tank transmitter is wired to TB4 (also marked TANK UNIT -TRANS) on the circuit board. The Black wire -is connected to position 1, the White wire is connected to position 2 and the Red wire is connected to position 3. Terminal block positions 1, 2 and 3 in the 2-412 tank transmitter follow the same numbering as on TB4.

The wiring and terminal block (TB4) are intrinsically safe and are physically separated from the AC power and relay contact and 4 to 20 wiring and terminal blocks on the right side (TB1, 2, 2A, 3). This separation must be maintained.

See Figure 8: System Wiring Diagram.

2-412 Installation (see Figure 2).

2-501 Installation (see Figure 3).

#### Section 3.2.2: Switch Sensor

PNEUMERCATOR makes a number of different LS-600 series switch sensors, which may be used with the E-14 and E-29. See the appropriate LS-600 bulletins for details on these. Any other mechanical switch closure may also be used as a switch input. The indicator must be ordered from the factory to accept a switch input at the SW input of TB4A. If this option is ordered, the two (2) wires of the switch are connected to TB4A positions 4 and 5 (also marked TANK UNIT - SW).

## OPERATION AND INSTALLATION MANUAL

---

Two (2) 18 AWG wires are required for a switch sensor. The wiring should be run through NEMA 4 or better junction boxes and 3/4" weatherproof liquid tight metal conduit. The metal conduit and junction boxes should be sealed against entry of water. If required, vapor seals may be installed to prevent gas vapors from propagating back to the console. The switch sensor wiring to the console should be run in a dedicated metal wiring conduit. No non-intrinsically safe wires should be in the same conduit unless a metal barrier is provided.

The wiring and terminal block (TB4A) are intrinsically safe and are physically separated from the AC power and relay contact and 4 to 20 wiring and terminal blocks on the right side (TB1, 2, 2A, 3). This separation must be maintained.

See Figure 8: System Wiring Diagram.

### Section 3.3: Electrical Installation

**WARNING:** Do not connect 120 VAC or turn on 120 VAC until all other connections have been made, all equipment has been installed, and final inspection has been completed.

The E-14 or E-29 requires a power input of 120 VAC,  $\pm 10\%$ , 60 Hz. The unit is fused with a 1/2 Amp, 3AG Slo-Blo fuse. Total power usage is less than 80 Watts. The power input is protected against common-mode power surges with a metal-oxide varistor (MOV). The power line for the alarm console should not share a breaker circuit with any motors, compressors, or other sources of power surges or voltage sags. The power wiring to the alarm console should be run in a dedicated metal wiring conduit. No other wires should be in the same conduit unless a metal barrier is provided. Three wires make up the power input to the E-14 or E-29: Black (hot), White (neutral), and Green (ground).

The AC power wires run to the terminal block labeled TB1, to positions 1, 2, and 3. Position 1, labeled 120V, is the hot lead. Position 2, labeled NEUT, is the neutral lead. Position 3, marked with a Ground symbol, is the ground lead. The terminal blocks will accept wire sizes up to 14 AWG stranded wire. The wiring and terminal block on the left side (TB4, 4A, 5) are intrinsically safe and are physically separated from the AC power and relay contact and 4 to 20 mA output wiring and terminal block on the right side (TB1, 2, 2A, 3). This separation must be maintained.

### IMPORTANT

Connect a 12 AWG copper wire from the terminal block TB5 (labeled Earth Ground) to a good earth ground. The ground connection must be within 1 OHM of true ground and must be made at only one point for the system to maintain intrinsic safety.

Properly dress all wires inside the wiring sections and securely clamp down the enclosure door and tighten all conduit entrances to seal the system watertight. Install vapor seals in accordance with local codes for hazardous locations if applicable.

## OPERATION AND INSTALLATION MANUAL

---

### Section 3.4: installation Checklist

Do not apply power to the unit until its installation has been checked and found to be in accordance with the instructions in this manual; the National Electrical Code; federal, state and local codes; and other applicable safety codes.

1. Check to be sure that the transmitter/sensor wires are contained in a dedicated, separate metal wiring conduit.
2. Verify that all conduits enter the alarm console through the proper conduit openings on the bottom of the console.
3. Verify that a 12 AWG copper wire has been connected between TB5 (labeled Earth Ground) and a good earth ground.
4. Verify that the power supply terminals are correctly wired.
5. Verify that system power is properly wired to a separate, dedicated circuit breaker.
6. Verify that all transmitters/sensors have been properly wired with colorcoded or marked 18 AWG wires and that the proper color-coding or marking has been maintained throughout the wiring runs.
7. Verify that all wiring splices are waterproof. Pneumercator part #100007-1 (epoxy splice kit) or equivalent or NEMA 4 or better junction box should be used for all wiring splices.
8. Securely clamp down the enclosure door.

## OPERATION AND INSTALLATION MANUAL

---

### Section 4: Operation

**IMPORTANT:** Before operating the system, make sure that all items on the installation checklist in the Installation section of this manual have been checked out and complied with.

Main Circuit Board layout (see Figure 4).

#### Section 4.1: Normal Operation

In normal operation there will be no alarm lights on and the horn will be silent. The dial will show the level of product in the storage tank in either gallons of volume or other specified engineering units.

The system will continuously monitor the level of product in the tank. Alarms will actuate the appropriate light and relay and the horn.

#### Section 4.2: The Horn

The volume of the audible alarm may be controlled by rotating the louver on the face of the horn. The maximum volume of the horn is a minimum of 85 dB at two feet, and the loudness may be varied by about 40 dB.

The horn may be reset (silenced) after detection of a warning condition by pressing the **RESET** button on the cover of the system console. This will silence the horn, but the condition light will remain on.

#### Section 4.3: The Relay Contacts and Alarm Settings

There are up to 4 relays in the system that provides SPDT Form C dry relay contacts. The terminal block relay contacts for the relays are brought out to TB2 and TB2A, and are labeled as Outputs 1 to 4, Normally Closed (NC), Common (C), and Normally Open (NO) positions. These contacts are rated to 5 amps at 120 VAC. Wire sizes up to 14 AWG stranded wire may be used to connect to these relay contact outputs. If the load on the relay contacts exceeds this rating then the relay should be used to actuate an external power relay of appropriate rating (not supplied by PNEUMERCATOR).

In the default setting, the relays are normally unenergized in a non-alarm state, and there is no continuity between the Normally Open (NO) and Common (C) contacts and there is continuity between the Normally Closed (NC) and Common (C) contacts. When an alarm condition is detected the relay actuates. This gives continuity between the Normally Open (NO) and Common (C) contacts, and breaks continuity between the Normally Closed (NC) and Common (C) contacts. The relays may be individually set to be in a normally energized state, which will toggle the meaning of the contacts. In this case, the relay(s) will de-energize on a programmed alarm condition. This may also be used to give indication of a power failure, since the relay will de-energize when the power is off.

**OPERATION AND INSTALLATION MANUAL**

---

The first two relay contacts are brought out to terminal block TB2 and are controlled by the relay card mounted in connector P3. The third and fourth relay contacts are brought out to terminal block TB2A and are controlled by the relay card mounted in connector P3A. Alarm lights are controlled by the appropriate relay card. The standard factory settings for alarms and relay contacts are for relays to energize upon alarm, and for Output 1 (relay card P3, side B) to be set for Low-level alarm. Output 2 (relay card P3, side A) is set as a High (overflow) alarm. If a relay card is present in connector P3A, the standard setting is for Output 3 (relay card P3A, side B) to be a Low-low alarm and for Output 4 (relay card P3A, side A) to be a High-high alarm. All standard settings energize the output relays on an alarm condition.

Each alarm switch may be individually set for High or Low actuating condition and for normally un-energized or normally energized relay state. Each alarm switch may be set to actuate at any level of tank product (see Section 4.5 : Calibrating Alarm Settings).

Each relay card has sets of shorting blocks that may be adjusted in order to customize the alarm conditions (see Figure 6: Relay Circuit Board Layout for the locations of these shorting blocks). Each shorting block has 3 numbered pins, 2 of which are shorted together by shorting plugs. See Figure 1 below for the schedule of Relay Card Settings.

Figure 1: Relay Card Settings

<u>Alarm A</u>	<u>Header A</u>	<u>Header C</u>
<u>Energized on Alarm</u>		
High	1:2, 4:5	3:2
Low	3:2, 6:5	3:2
<u>De-energized on Alarm</u>		
High	3:2, 6:5	1:2
Low	1:2, 4:5	1:2
<u>Alarm B</u>	<u>Header B</u>	<u>Header D</u>
<u>Energized on Alarm</u>		
High	1:2, 4:5	3:2
Low	3:2, 6:5	3:2
<u>De-energized on Alarm</u>		
High	3:2, 6:5	1:2
Low	1:2, 4:5	1:2

Notes: Shorting block E always should have pins 1 & 2 shorted together. Shorting block F is unused. Power must be off while setting the shorting blocks.

## OPERATION AND INSTALLATION MANUAL

---

### Section 4.4: The Simulator

The E-14 and E-29 come with a built-in tank simulator that may be used to check operation and calibration of the alarms and horn and also to verify proper operation and calibration of the indicator unit.

When the momentary pushbutton switch labeled Simulator Switch is pushed and held the tank transmitter and associated wiring are electrically disconnected, and the miniature dial and pointer next to the Simulator Switch controls the pointer position. The full range of travel of the pointer may be induced by rotating the internal simulator control knob. The actuation points of alarms may be checked by setting the pointer to the desired actuating level and verifying operation of the lights and relay contacts. Gauge operation may be verified by using the control knob to move the pointer over the full span of travel.

See Figure 5: Indicator Circuit Board Layout for simulator.

### Section 4.5: Calibrating Alarm Settings

Each alarm setting may be individually calibrated to actuate at any product level. The setting for the A-side is controlled by a potentiometer labeled R5 on the relay card. The setting for the B-side is controlled by a potentiometer labeled R6 on the relay card. By depressing and holding the simulator button, the pointer may be set at the level desired for alarm actuation. When the desired level is set, the alarm point for that alarm may be adjusted by turning R5 or R6 while continuing to hold the simulator button. At the desired point the light (if present) will turn on, and the relay contacts will change state. Turning R5 or R6 (with a small screwdriver) in a clockwise direction will increase the setting and turning in a counter-clockwise direction will decrease the setting. Alarm settings may be checked and verified by using the simulator to control the pointer position.

See Figure 4: Main Circuit Board Layout for terminal blocks.

See Figure 5: Indicator Circuit Board Layout for simulator.

See Figure 6: Relay Circuit Board Layout for R5, R6 positions.

## OPERATION AND INSTALLATION MANUAL

---

### Section 4.6: 4 to 20 mA Output

The optional 4 to 20 mA output can be used to feed a current output to process control equipment, energy management systems or chart recorders. The normal 4 to 20 mA module has a non-isolated output and can drive loads with a maximum impedance of 500Ω. The minus (-) line of the output should not be connected to ground either directly or through a resistance. If the equipment that will receive the signal has a grounded input, then the output of the 4 to 20 mA converter must be isolated, either by an in-line isolation module or by ordering the system with a special isolated 4 to 20 mA converter.

The output provided will be as a percentage of gaugeable product height. 4 mA will always represent the minimum gaugeable product level. 20 mA will always represent the maximum gaugeable product level. The current output will be a linear percentage of the product height between the minimum and maximum gaugeable levels. No compensation for tank geometry or inches to gallon conversion is provided.

The 4 to 20 mA converter module is factory calibrated and normally needs no user adjustment. If it is necessary to re-calibrate the module, the simulator may be used to set the E and F calibrations. The simulator button should be depressed and held and the pointer adjusted to read E. The output should be adjusted to 4 mA at terminal block TB3 by turning potentiometer R8 (labeled 4mA) on the converter card. The pointer should then be set to F and an output of 20 mA should be read at terminal block TB3 by adjusting potentiometer R6 (labeled SPAN). The adjustments should be repeated a number of times, since there is some interaction between the 4mA and SPAN settings. The potentiometer R7 (labeled ZERO) is unused for these adjustments.

### Section 4.7: Switch Inputs

The models LCE-14 and LCE-29 are factory configured to accept a switch input at the SW input of TB4A. These models provide a relay contact at Output 3 of terminal block TB2A that will change state when a mechanical switch closure occurs. The default is that the relay contacts will energize when the switch closes. The relay may be set to de-energize on a switch closure by changing the shorting plugs on relay card P3A side B.

<u>Alarm B</u>	<u>Header B</u>	<u>Header D</u>
Energized on Switch Closure	1:2, 4:5	3:2
De-energized on Switch Closure	3:2, 6:5	1:2

Notes: Shorting blocks E and F are unused. Power must be off.

### Section 4.8: Master-Slave Option

The E-14 and E-29 may be ordered from the factory with a Master-slave option where a slave indicator is controlled by a master indicator. The slave indicator may have lights, horn and output contacts. Consult the factory for ordering, wiring, repair and replacement information.

## OPERATION AND INSTALLATION MANUAL

---

### Section 5: Troubleshooting & Servicing

PNEUMERCATOR CO., INC.  
120 Finn Court  
Farmingdale, NY 11735  
(631) 293-8450 Phone  
(631) 293-8533 Fax  
(800) 209-7858 Product Support  
[www.pneumercator.com](http://www.pneumercator.com)

The PNEUMERCATOR E-14/E-29 systems and all components are factory warranted for a period of 1 year from the date of shipment. No materials should be returned to the factory without first getting a Returned Materials Authorization number from PNEUMERCATOR. All materials returned should be marked with this RMA number. All returned merchandise should be shipped pre-paid. No collect shipments will be accepted by the shipping department.

Because of the intrinsically safe operation of the system no field repairs other than fuse changing or circuit board replacement should be attempted. All other repairs should be done only at the factory or at a factory authorized repair center.

The E-14 and E-29 series of tank gauges are modularly constructed so that individual modules may be replaced for repair. A complete tank gauging system consists of 3 subsystems: indicator, tank transmitter/sensor and interconnecting wiring. The main task in troubleshooting is to isolate the problem to one of the subsystems.

The serial number for the indicator is marked on the face of the dial in a form of a letter followed by at least 4 numbers. Examples: S/N R1234 and S/N R1234-1. This number is required to check any information about the order and for receiving a Return Merchandise Authorization (RMA) number.

The two most common causes of problems are incorrect or improper installation of equipment, and water in the electrical lines.

#### Indicator Tests

Equipment required: DC voltmeter/ohmmeter.

See Figure 4: Main Circuit Board Layout for locations of P1, P2, P3, P3A, Simulator, J2, TB4, TB4A and fuse.

1. Perform a visual check that all wiring is connected properly and that all printed circuit modules are properly seated in the edge card connectors. Check that the fuse is good and that the AC power is properly connected and on.
2. Hold down the Simulator Switch pushbutton and rotate the Simulator knob from E to F positions. The pointer on the dial should respond according to the Simulator knob position.

**OPERATION AND INSTALLATION MANUAL**

---

3. If the indicator responds to the simulator test, then the problem is in the tank transmitter or the interconnecting wiring. Proceed with the tank transmitter tests.
4. Using a voltmeter set to the 20 VDC range (or equivalent) measure the voltage between pin 1 (ground) and pin 3 (+12V) of J2. J2 is located just above TB2A on the main circuit board. The voltage measured should range between +10 VDC and +14 VDC. Repeat the measurement between pin 1 (ground) and pin 4 (-12V) of J2. The voltage measured should range between -10 VDC and -14 VDC.

	<u>J2</u>	<u>PIN</u>	<u>VOLTAGE</u>
top	o	1	GROUND
	o	2	TRANSMITTER INPUT
	o	3	+12 VDC
bottom	o	4	-12 VDC

5. If the measurements are not within the acceptable range, power down the indicator and remove all plug-in circuit cards from P1, P2, P3, and P3A. Power up the indicator and repeat the measurements taken in the previous step with the plug-in cards removed. If the measurements taken are now within the acceptable ranges, one of the plug-in cards is bad. Replace each one (with power off), repeating the voltage measurements after each card has been replaced. The card that causes the improper readings should be replaced.
6. If the voltage measurements are correct but the pointer keeps circling the dial during the Simulator test, the indicator circuit card in P1 needs to be replaced.
7. If one or more of the lights or relay contacts do not operate, check the actuation point(s) using the simulator to make sure that the alarm is set correctly. If the load connected to a relay contact exceeds 5 Amps, damage to the relay circuit card and or the main circuit board will result. Any defective relay cards or main circuit board should be replaced.

See Section 6: Circuit Board Part Numbers for replacement assembly ordering numbers.

## OPERATION AND INSTALLATION MANUAL

---

### Tank Transmitter Tests

Equipment required: DC voltmeter/ohmmeter.

See Figure 2: 2-412 Installation \ to identify tank

See Figure 2: 2-501 Installation / transmitter installed.

The tank transmitters are completely sealed units and cannot be repaired in the field. However, a series of simple measurements can be made to verify if the tank transmitter unit is operational.

1. Perform a visual check that all wiring is connected properly and that no water is present in any wiring splice or in the housing of the model 2-412 tank transmitter. Make sure that the tank transmitter is installed according to the instructions for that model, and according to how it was ordered (tank size and diameter, mounting specified).
2. If water is present in a splice or in the wiring it must be dried out. All splices should be waterproofed. Pneumercator part #100007-1 (epoxy splice kit) or equivalent or NEMA 4 or better junction box should be used for all wiring splices.
3. If water is present in the housing of the model 2-412 tank transmitter, it must be removed and the housing circuit board (part #900310-1) inspected for water damage. If this part is damaged, it may be replaced in the field.
4. Power down the indicator unit and disconnect the field wiring from TB4 of the indicator. Connect an ohmmeter between the wires that were in TB4, pin 1 and pin 3. The resistance measured should be 2000 ohms. There should be continuity between the wires for pin 1 and pin 2, and the wires for pin 2 and pin 3.
5. If the readings are out of range, they should be repeated at the housing of the tank unit (either at the terminal block inside the housing of the model 2-412 or at the wire pigtail coming out of the housing of the model 2-501). These measurements should be made with all interconnecting wiring disconnected. If the measurements are now correct, the problem is in the interconnecting wiring.
6. If the float position is either at empty or full, a further resistance check may be made.

#### Resistance readings (in ohms)

	<u>Empty</u>	<u>Full</u>
1 to 3 (Black to Red)	2000	2000
1 to 2 (Black to White)	255	1945
2 to 3 (White to Red)	1745	55

## OPERATION AND INSTALLATION MANUAL

---

7. Pull the tank transmitter out of the tank. Check that the float moves freely on the rod (model 2-412) or that the float arm moves freely (model 2-501). Make sure that no parts were damaged in shipping or installation.
8. If the resistances are out of tolerance or physical damage has occurred the tank transmitter must be returned to the factory for repair or replacement.

### Section 6: Circuit Board Part Numbers

Relay Circuit Board (with horn)	900297-2
Relay Circuit Board (no horn)	900297-5
4 to 20 mA Circuit Board	900325-1
Main Board (2 relay cards & 4 to 20 mA)	900362-2
Main Board (1 relay card & 4 to 20 mA)	900362-4
Main Board (2 relay cards)	900362-9
Main Board (1 relay card)	900362-11
Indicator Circuit Board	900363-1
Model 2-412 Tank Transmitter Housing Board	900310-1

**OPERATION AND INSTALLATION MANUAL**

---

**Figure 2 - 2-412 Installation****STEPS FOR A TROUBLE FREE INSTALLATION****STEP 1 - EXAMINE THE SHIPMENT**

1.1 Each system consists of two main components, which are packed separately, the transmitter float assembly and the indicator unit. Make sure you have both parts. If cartons are missing or damaged, have the fact noted on the delivery receipts to permit a claim to be filed against the transportation company.

1.2 Match the transmitter float assembly Serial No. with the Serial No. on indicating unit to insure compatibility.

1.3 The transmitter float assembly should be checked for damage, which may have occurred during shipping. The float switch should move freely from the bottom stop to the top stop on the rod. If the float can be rotated on the rod, then the float guides have been damaged. If any problems arise, contact the factory.

**DO NOT ATTEMPT TO INSTALL DAMAGED UNITS.**

**STEP 2 - MAKE SURE THE SYSTEM MATCHES YOUR JOB**

2.1 Compare the actual tank dimensions and capacity with the tank dimensions and capacity on the packing slip and the transmitter mounting tag to insure compatibility.

2.2 Standard construction is suitable for most petroleum products.

2.3 For potentially corrosive liquids, verify the liquid's compatibility with stainless steel and Teflon. When the unit is supplied with a water switch, verify the compatibility of the liquid with nitrophyl.

2.4 Verify that the tank is set level. To obtain accurate readings from a tilted tank, the indicator must be ordered with a special calibration.

BULLETIN 104-E-Series

OPERATION AND INSTALLATION MANUAL

Figure 2 - 2-412 Installation (Continued)

**STEP 3 - SELECT THE CORRECT LOCATION FOR THE INSTALLATION OF THE TRANSMITTER FLOAT ASSEMBLY**

3.1 The transmitter float assembly should be installed through a 4" NPT half coupling in the top of the tank as shown in figure 2-1. It is recommended that a strike plate be situated directly below the coupling. If the unit is to be standpipe mounted, it should have been ordered for the special mounting height (\*) and installed as shown in figure 2-2.

3.2 When the tank is indoors, sufficient clearance must be provided between tank and ceiling to permit installation and removal of the transmitter float assembly.

3.3 When the tank is underground, a suitable chamber and cover should be provided to permit installation and removal of the transmitter float assembly should it ever be required. This is especially important when the tank is to be covered with pavement or concrete. Do not bury tank unit.

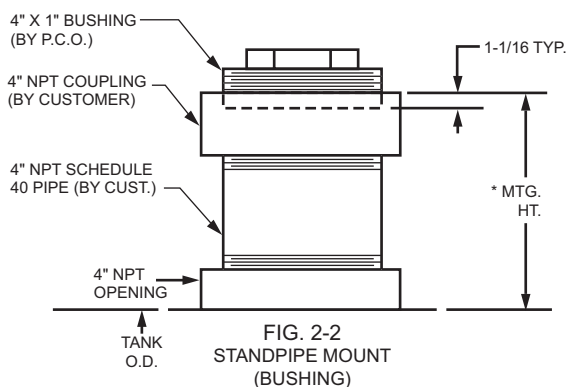
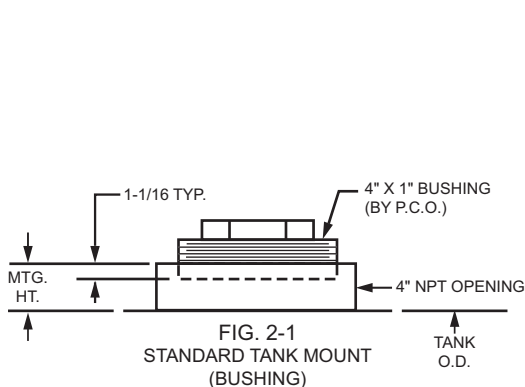

**STEP 4 - INSTALL WITH CARE**

4.1 Screw the mounting bushing 1-1/16" into the proper opening in the top of the tank (see figure 2-1). There should be a clearance of at least 2.0" between the bottom of the probe and the bottom of the tank (see figure 2-3).

4.2 When using a standpipe, screw the mounting bushing 1-1/16" into the 4" NPT coupling on top of the standpipe (see figure 2-2). There should be a clearance of at least 2.0" between the bottom of the probe and the bottom of the tank (see figure 2-3).

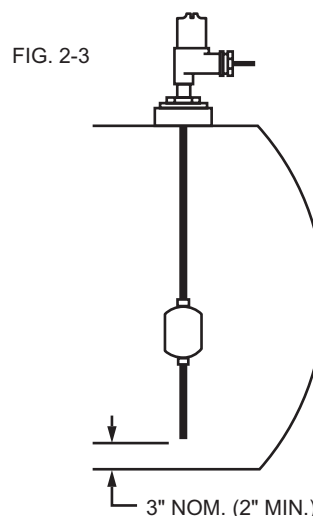

OPERATION AND INSTALLATION MANUAL

Figure 3 - 2-501 Installation

STEPS FOR A TROUBLE FREE INSTALLATION

1. Examine the shipment
2. Make sure the system matches your job
3. Select the correct location for the transmitter
4. Install the transmitter float assembly with care

STEP 1 - EXAMINE THE SHIPMENT

1.1 The system consists of two components, which are packed separately, the transmitter and the indicator. Make sure you have both parts. If cartons are missing or damaged note the delivery receipts to permit a claim to be filed against the transportation company.

**DO NOT ATTEMPT TO INSTALL DAMAGED UNITS.**

1.2 Match the serial no.'s on the transmitter and indicator to insure compatibility.

STEP 2 - MAKE SURE THE SYSTEM MATCHES YOUR JOB

- 2.1 Compare the dimensions and capacity on the packing slip with the tank drawing to insure compatibility.
- 2.2 Check that the tank is vented to atmosphere unless the order shows the system was designed for a pressurized tank.
- 2.3 Verify that the tank contents will not corrode the unit's wetted parts (Alum., Brass, Buna-N, nylon, 303 Stainless). Standard construction is suitable for most petroleum products.
- 2.4 Verify that the tank is set level. (Tilted tanks require special calibration.)

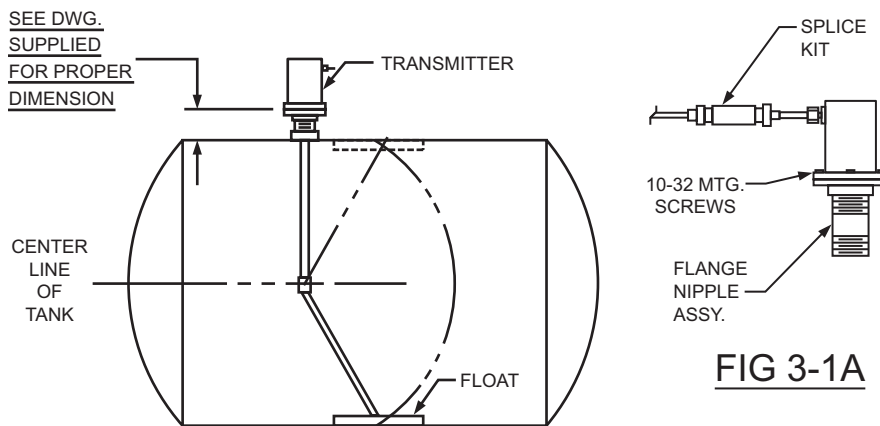

NOTE: THE FLOAT ARM SHOULD SWING UPWARDS TOWARDS THE CONNECTOR ON THE HOUSING.

## OPERATION AND INSTALLATION MANUAL

### Figure 3 - 2-501 Installation (Continued)

#### STEP 3 - SELECT THE CORRECT LOCATION FOR THE TRANSMITTER

3.1 Standard installation requires a 2" half coupling in the top of the tank. The fulcrum pipe will then reach the mid-point of tank as required for accurate measurement. If the transmitter is to be installed through a manway or a riser, it must be ordered with an extra long fulcrum pipe. **THERE IS NO WAY TO ADJUST THE SYSTEM FOR ACCURATE GAUGING IF THE PIVOT LEVER IS NOT CORRECTLY POSITIONED.** (See Figure 3-1 & 3-2)

3.2 The float arm must swing in an arc along the axis of the tank without hitting the end of the tank or other obstructions and not extend under manways or fill lines.

3.3 When tank is indoors, sufficient clearance must be provided to permit installation of the fulcrum pipe, which is approximately one-half the tank diameter plus 11 inches.

3.4 When the tank is underground or covered by pavement, a chamber should be provided to permit access to the transmitter. Covers to access chambers should provide clearance for installation and removal of the fulcrum pipe. (See 3.3 above).

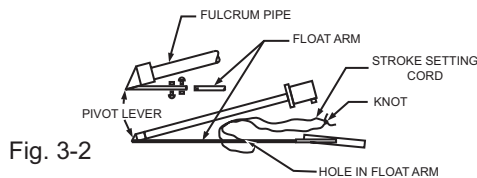

Fig. 3-2



Fig. 3-2A

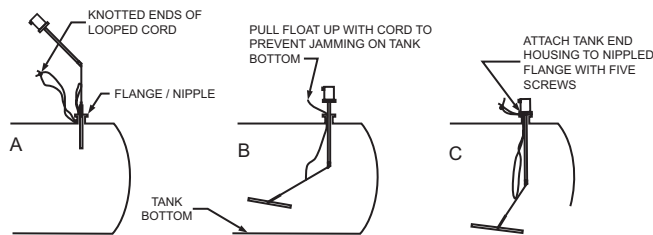

Fig. 3-3

#### STEP 4 - INSTALL THE TRANSMITTER WITH CARE

4.1 The transmitter should be installed when the tank is empty. Although it is possible to install when the liquid is below the tank mid-point, there is no way to verify factory settings and adjustments.

4.2 The flange / nipple has been pre-removed to protect the float arm assembly during installation. **DO NOT** re-attach until after the float arm assembly is in the tank.

4.3 Screw the flange / nipple into the proper tank opening. Align flange so float will rise and fall along the centerline of tank when transmitter assembly is installed. (Flange must be level). \*Position gasket on flange using a suitable sealing compound on both sides.

**NOTE: THE DIMENSION BETWEEN THE TANK TOP AND TOP OF THE FLANGE (SEE ATTACHED TAG) MUST BE EXACT FOR THE PIVOT TO REACH THE MIDPOINT OF THE TANK AS REQUIRED FOR ACCURATE GAUGING.**

4.4 Attach the float arm to the pivot lever using the two bolts furnished. Insert the stroke setting cord through hole in float arm, then through hole in the nipple and knot ends together. (NOTE: MUST BE RE-INSTALLED UPON COMPLETION OF INSTALLATION.) (See Figures. 3-2 & 3-2A)

4.5 Insert the transmitter float assembly through the flange / nipple. (See Figure 3-3.) Note: the direction of float travel is toward the cable in the transmitter housing. **DO NOT LET FLOAT ARM SWING BACKWARDS DURING INSTALLATION!**

4.6 Attach the transmitter float assembly to the flange / nipple using the screws from 4.2. Tighten all five screws evenly to assure a tight seal. (See Fig. 3-1A).

4.7 Raise and lower the float arm with the stroke setting cord. Make certain that the float and arm move freely (DO NOT FORCE) from bottom to top of the tank unobstructed.

BULLETIN 105-E-Series



OPERATION AND INSTALLATION MANUAL

Figure 5 - Indicator Circuit Board Layout

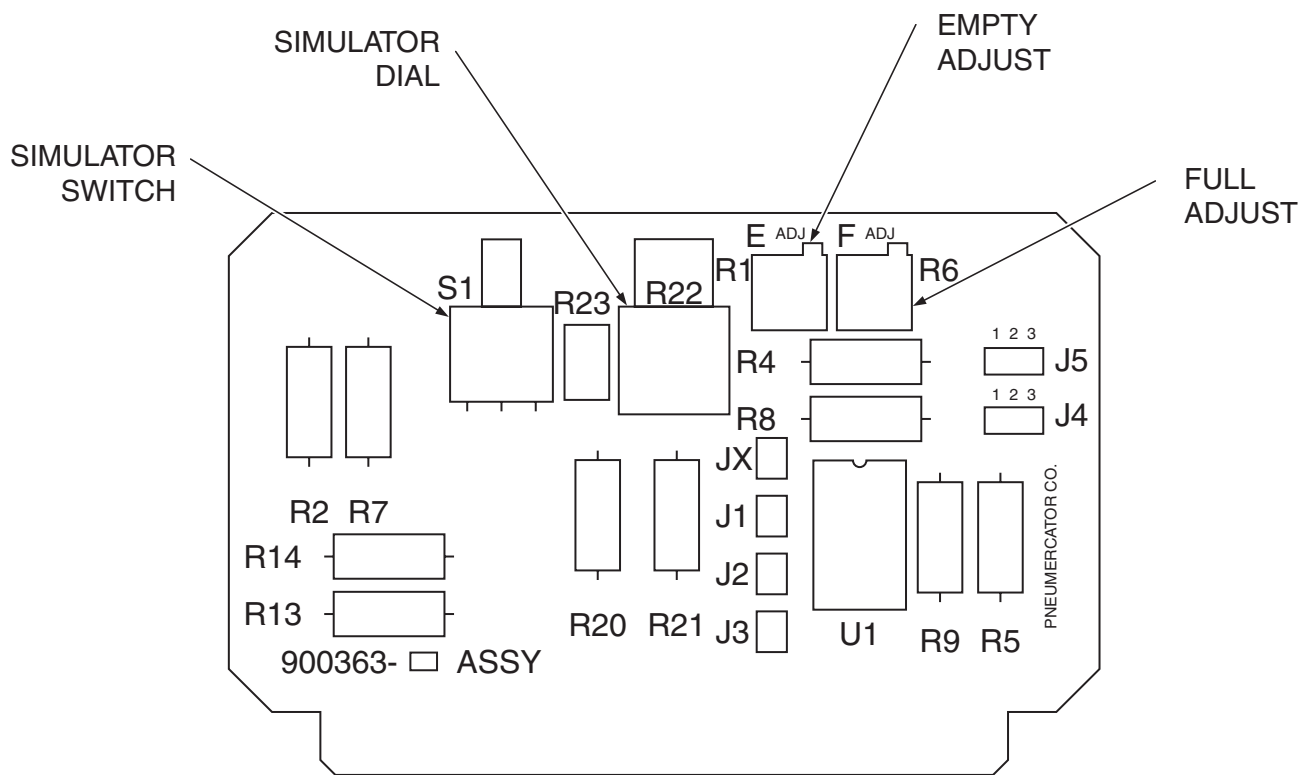

### OPERATION AND INSTALLATION MANUAL

Figure 6 - Relay Circuit Board Layout

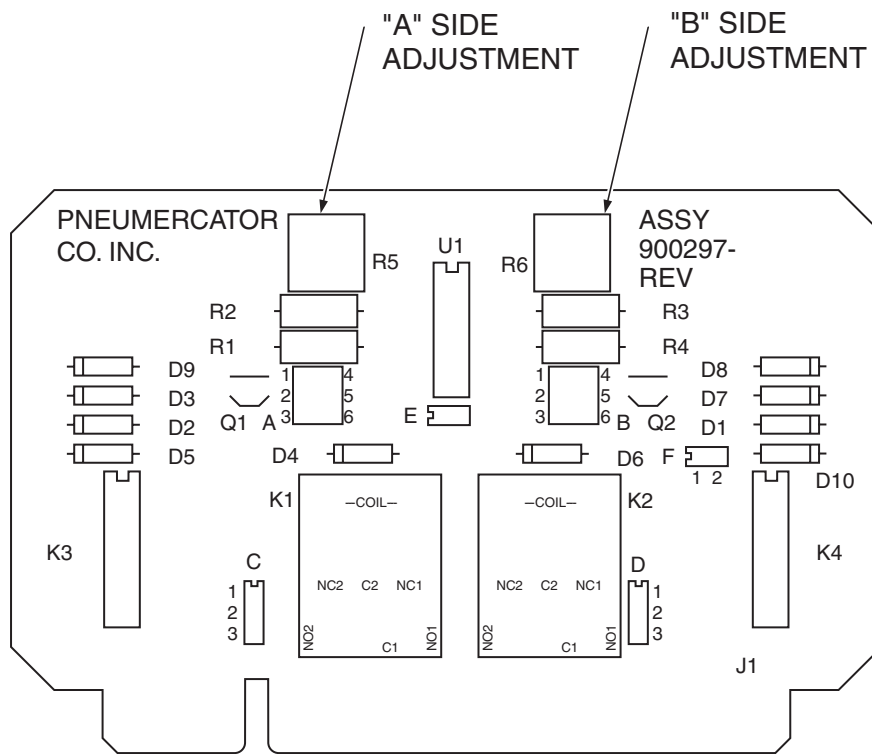

OPERATION AND INSTALLATION MANUAL

Figure 7 - 4 to 20 mA Circuit Board Layout

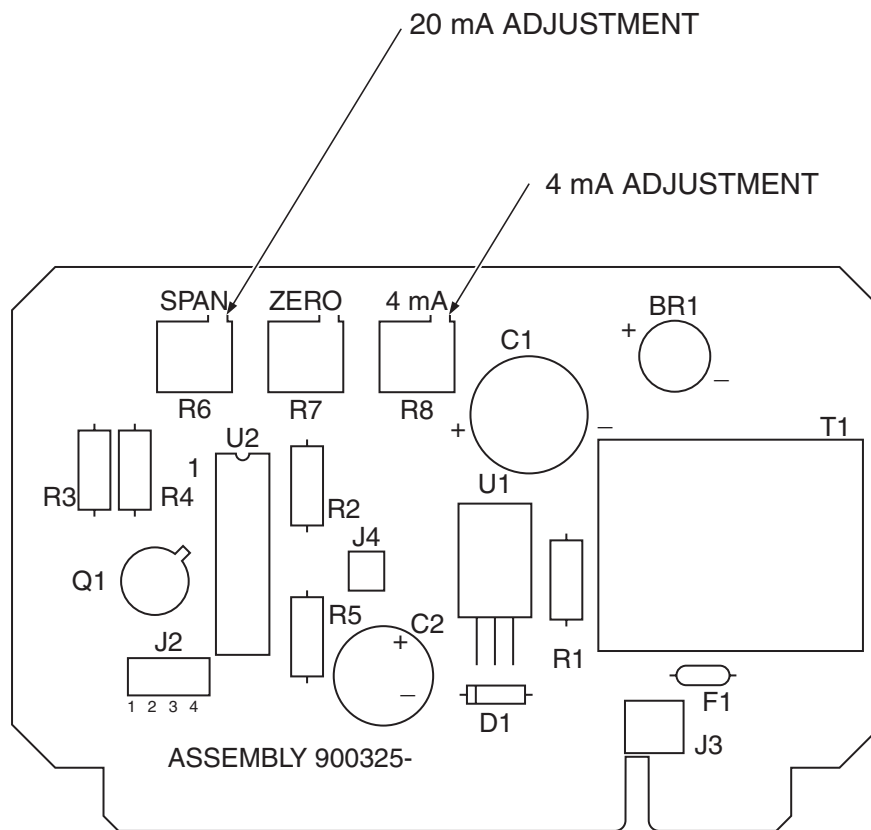

OPERATION AND INSTALLATION MANUAL

Figure 8 - System Wiring Diagram

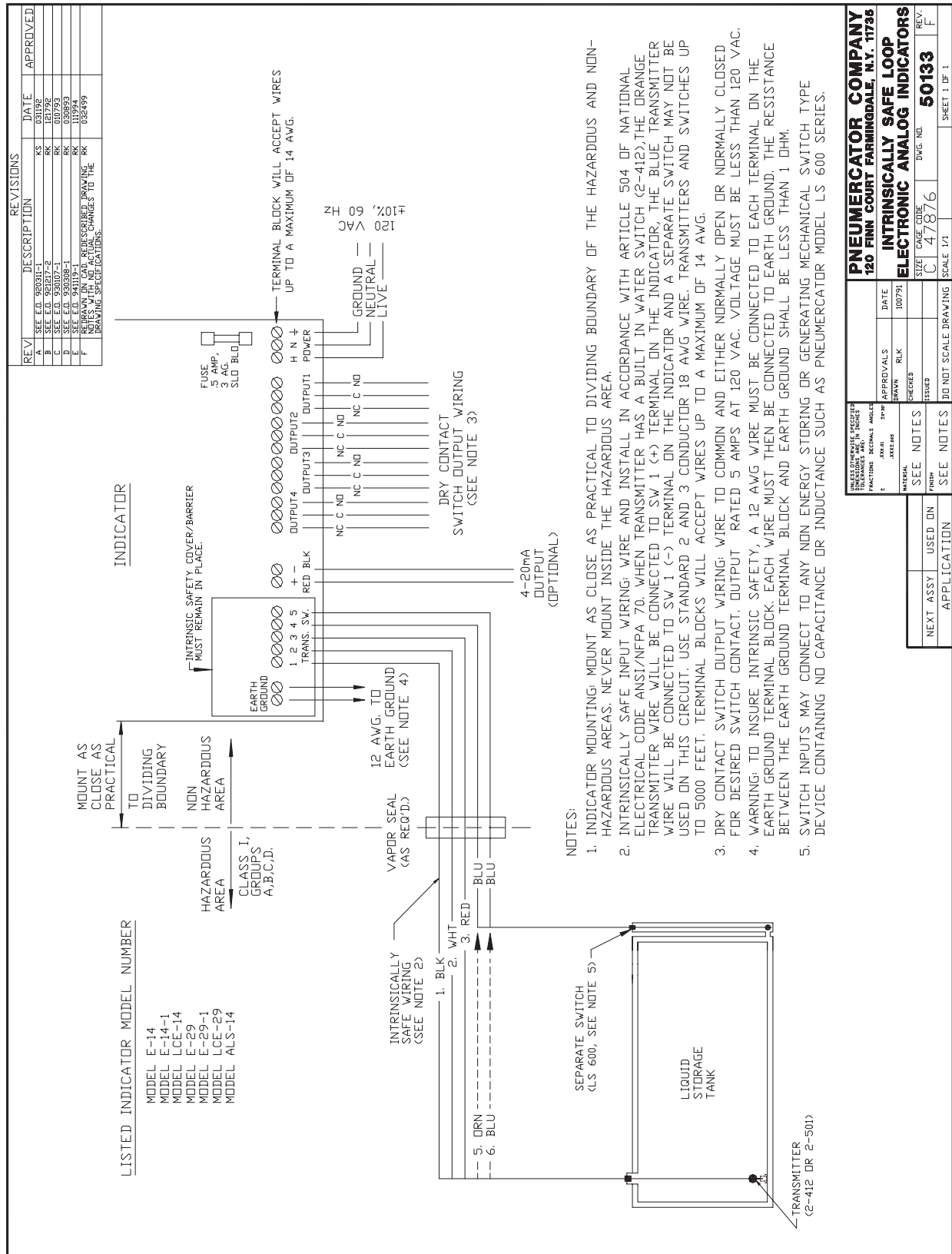

### Warranty

We warrant that our equipment, if installed according to instructions will be free from defects in material and workmanship for a period of one (1) year following the date of original shipment by Pneumercator.

Our liability under this warranty shall be limited to, at our option,

- (i) repair of the defective equipment,
- (ii) replacement of the original equipment with new equipment, or
- (iii) refund of the original purchase price; and, we shall not be liable for any labor, other installation costs, indirect or consequential damages, or other damages in connection with such equipment.

This constitutes our obligation and none other stated for any purpose except the above shall apply.

rev051294



Pneumercator Co.  
120 Finn Court, Farmingdale, NY 11735  
TEL: (631) 293-8450 • FAX: (631) 293-8533  
[www.pneumercator.com](http://www.pneumercator.com)

Distributed by:

--