

INSTALLATION INSTRUCTIONS

DIRECT READER

STEPS FOR A TROUBLE FREE INSTALLATION

1. Examine the shipment
2. Make sure the system matches your job
3. Select the correct location for the gauge
4. Install the gauge with care

Step 1 - EXAMINE THE SHIPMENT

1.1 If the carton is damaged, have the fact noted on the delivery receipts to permit a claim to be filed against the transportation company.

DO NOT ATTEMPT TO INSTALL DAMAGED UNITS.

Step 2 - MAKE SURE THE SYSTEM MATCHES YOUR JOB

2.1 Compare the tank information on the packing slip with the actual tank dimensions and capacity on the tank drawing to insure compatibility.

2.2 Verify that the tank contents will not corrode the wetted parts (Aluminum, Brass, Buna-N, Nylon, 303 Stainless) of the float assembly. Standard construction is suitable for most petroleum products.

2.3 Verify that the tank is set level. To obtain accurate readings from a tilted tank, the gauge must be ordered with special dial calibration.

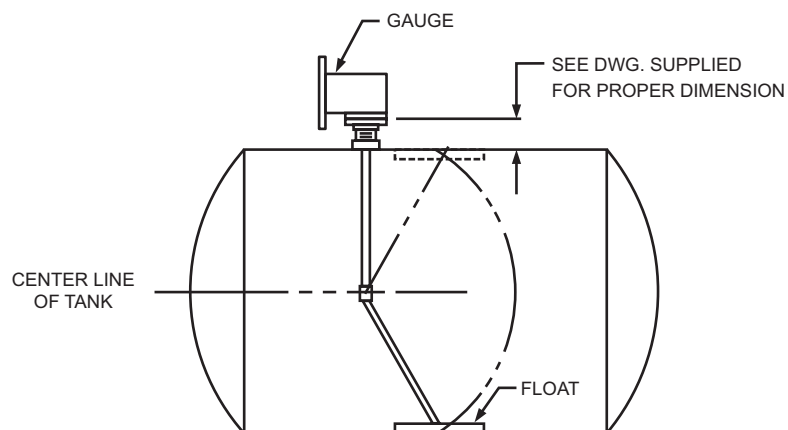

Figure 1

Step 3 - SELECT THE CORRECT LOCATION FOR THE GAUGE

3.1 The gauge should be installed through a 2" half coupling in the top of the tank. The fulcrum pipe will then reach the mid-point of the tank as required for accurate measurement. If the gauge is to be installed through a manhole or a stand-off nipple it must be specially ordered with an extra long fulcrum pipe.

Be sure to install with the correct 90° position for viewing. Check your original order for your specifications.

3.2 The float arm must be free to swing in an arc along the axis of the tank without hitting any obstructions and should not extend under any manhole or fill lines.

3.3 When the tank is indoors, sufficient clearance must be provided between tank and ceiling to permit installation of the fulcrum pipe which is approximately one-half the tank diameter plus 11 Inches.

3.4 When the tank is underground, a suitable chamber with a cover should be provided to permit viewing of the gauge. This is especially Important when the tank is to be covered with pavement or concrete. Covers to access chambers also should provide clearance for installation and removal of the fulcrum pipe. (See 3.3 above).

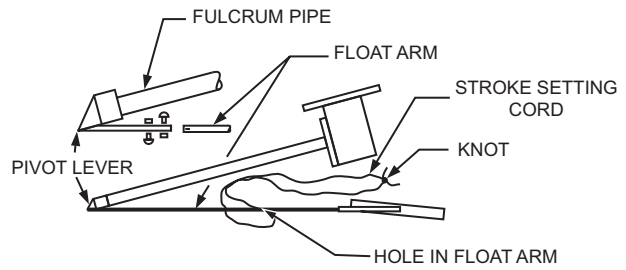

Figure 2

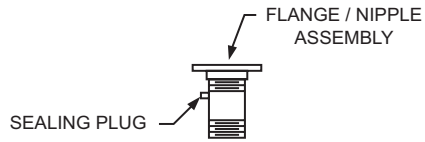

Figure 2A

Step 4 - INSTALL THE GAUGE WITH CARE

4.1 The gauge should be installed when the tank is empty, although it is possible to install the assembly when the tank contains liquid.

Note: The flange assembly or flange/nipple assembly has been pre-removed for the protection of the float arm assembly during installation. DO NOT re-attach until after the float arm assembly is in the tank.

4.2 Screw the nipple/flange assembly into the proper opening on the top of the tank, align the flange so the float will rise and fall along the centerline of the tank when the assembly is installed. The face of the flange must be level. *Position the gasket on the flange using a suitable sealing compound on both sides.

Note: The dimension between the top of the tank and top of the flange (see dwg. attached to the fulcrum pipe) must be exact in order for the pivot end of the fulcrum pipe to reach the midpoint of the tank as required for accurate gauging.

4.3 Attach the float arm to the pivot lever using the two bolts furnished. Insert the stroke setting cord through hole in float arm, then through hole in the nipple plug and knot ends together. (NOTE: Sealing plug must be removed during this procedure. PLUG MUST BE RE-INSTALLED UPON COMPLETION OF INSTALLATION.) (See Figs. 2 & 2A).

4.4 Insert the gauge through the nipple/flange following the procedure shown in Fig. 3. **DO NOT LET FLOAT ARM SWING BACKWARDS DURING INSTALLATION!**

4.5 Check for the proper viewing position of the dial face, then attach the gauge to the nipple/flange using the screws from 4.2. Tighten all five screws evenly to assure a tight seal.

4.6 Raise and lower the float arm by means of the stroke setting cord to make certain that the float and arm move freely (DO NOT FORCE) all the way from bottom to top of the tank without hitting or rubbing against other components.

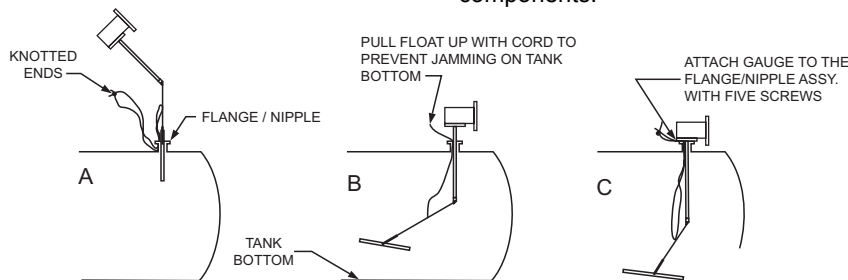

Figure 3