

## TMS Series Analog Output Board Installation Instructions

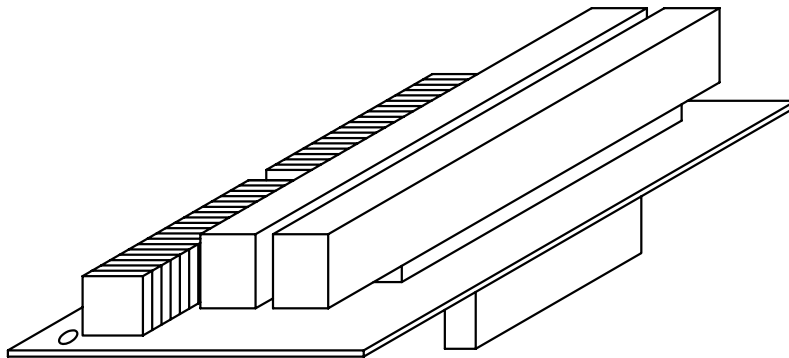

**Installation For: Model TMS2000  
and Model TMS3000**

*© COPYRIGHT 2004 PNEUMERCATOR CO., INC.  
120 FINN COURT, FARMINGDALE, NY 11735*

TEL: (631) 293-8450  
FAX: (631) 293-8533  
PNEUMERCATOR TECHNICAL SUPPORT  
1 (800) 209-7858

**PRODUCT DESCRIPTION:** The TMS series analog output board is a plug-in option for both the TMS2000 and TMS3000 Tank Management Systems which provides either six (6) or twelve (12) channels of non-isolated current loop output data, globally selectable for 0-20ma, 0-24ma or 4-20ma ranges. The 0-20ma range is also scaleable for 0-1ma, provided the TMS firmware is at release Vxx.99.91 or later, or version Vxx.00.xx. These outputs can be connected to most programmable logic controllers, building management systems, and similar analog input monitoring devices to provide continuous tank data without the need for communications protocol support. Each current loop channel is field programmable by tank number and data type, including gross volume, net volume, product level, water level and product temperature. If desired, voltage outputs, for example 0-5v, 1-5v or 0-10v can easily be configured using an external resistor. The TMS series analog output board requires no calibration and provides full scale accuracy better than +/-0.05% of full scale.

**INSTALLATION/SETUP:** Before installing the analog output board in your system, be sure TMS power is off, and that you have the correct assembly for your system.

Board with Module(s)	Board	Module	Description
900497-1	900494-1	(1) 900501-1	TMS2000 6-Channel
900497-2	900494-2	(2) 900501-1	TMS2000 12-Channel
900496-1	900489-1	(1) 900501-1	TMS3000 6-Channel
900496-2	900489-2	(2) 900501-1	TMS3000 12-Channel

**NOTE:** 6-Channel boards have (1) set of terminal blocks and (1) plug-in module. 12-Channel boards have (2) sets of terminal blocks and (2) plug-in modules.

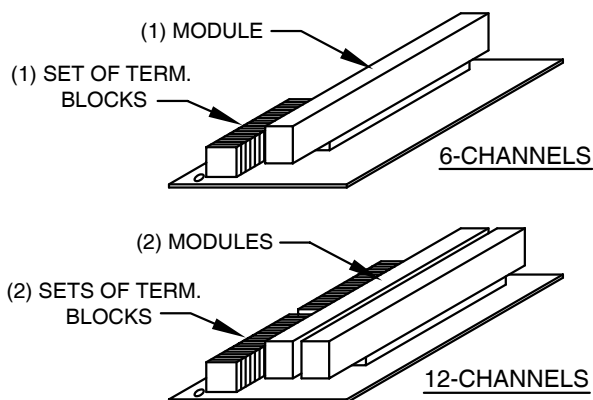

**IMPORTANT TMS2000 NOTE:** The TMS2000 system main board has two snap-top stand-offs which help to align and support the analog board plugged into the expansion card position, as shown in figure below. On some earlier main boards, two additional standoffs were installed, also shown below. Inspect your main board to be sure that these two additional standoffs are **NOT** present. If they are, consult Pneumercator technical support before proceeding. Failure to do so may damage analog board and void product warranty. Also, **DO NOT** attempt to remove these standoffs. Improper removal will damage main board and void system warranty.

PROCEED WITH INSTALLATION

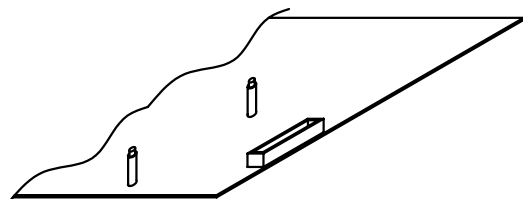

PROPER TMS2000 MAIN BOARD

CONSULT TECHNICAL SUPPORT

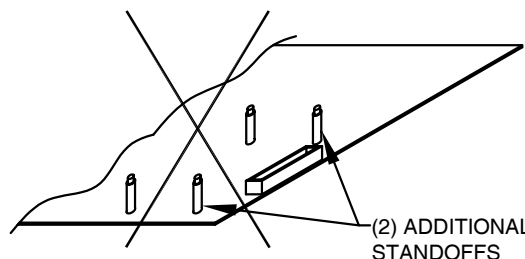

EARLIER TMS2000 MAIN BOARD

PNEUMERCATOR TECHNICAL SUPPORT 1 (800) 209-7858

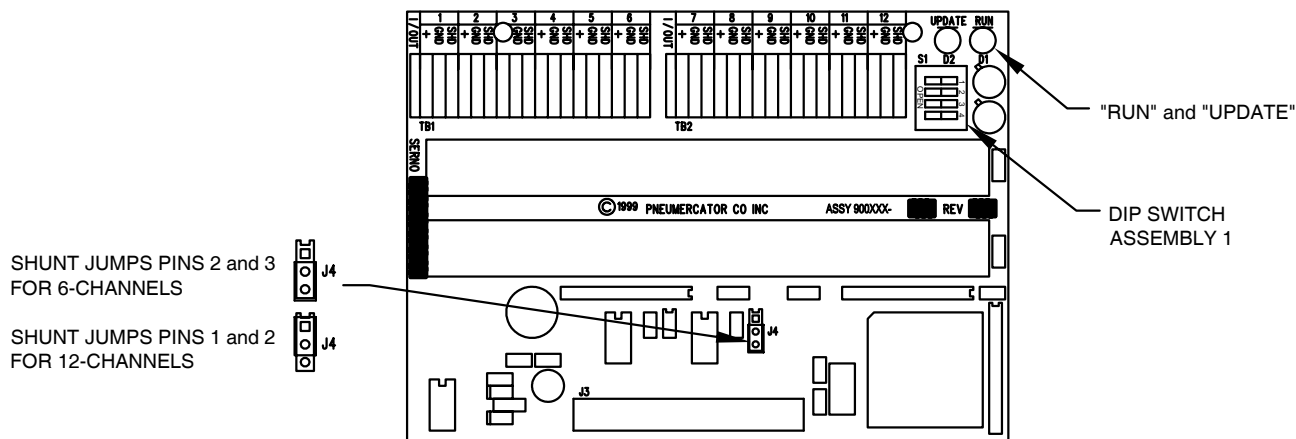

FIGURE 1

TABLE 2 -DIP SWITCH SETTINGS					TMS GAIN SELECT **
OUTPUT RANGE	1	2	3	4	
4-20ma	C	C	C	C	1.00
4-20ma	C	C	O	C	1.00
0-20ma	C	C	C	O	1.00
0-24ma	C	C	O	O	1.00
0-1ma*	C	C	C	O	0.05

WHERE: C = CLOSED, O = OPEN

EXAMPLE SETTING

OPEN SETTING MARKED "OPEN"

CLOSED SETTING

SWITCH NUMBERS

\* Requires TMS firmware release Vxx.99.91 or later, or version Vxx.00.xx.

\*\* Firmware releases prior to Vxx.99.91 do not support GAIN SELECT and instead have a fixed gain of 1.00.

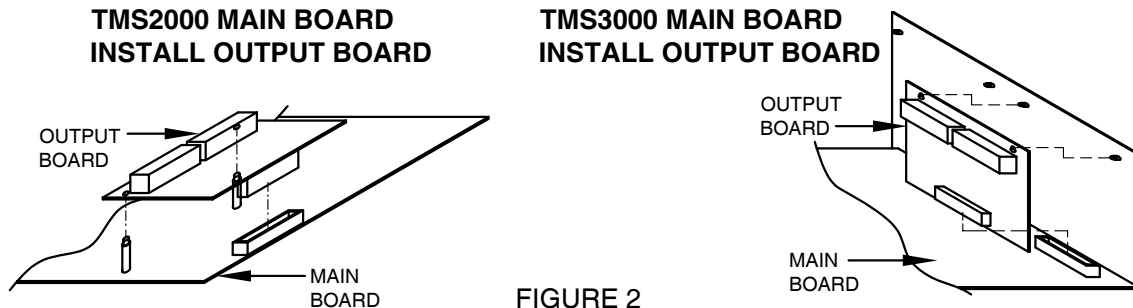
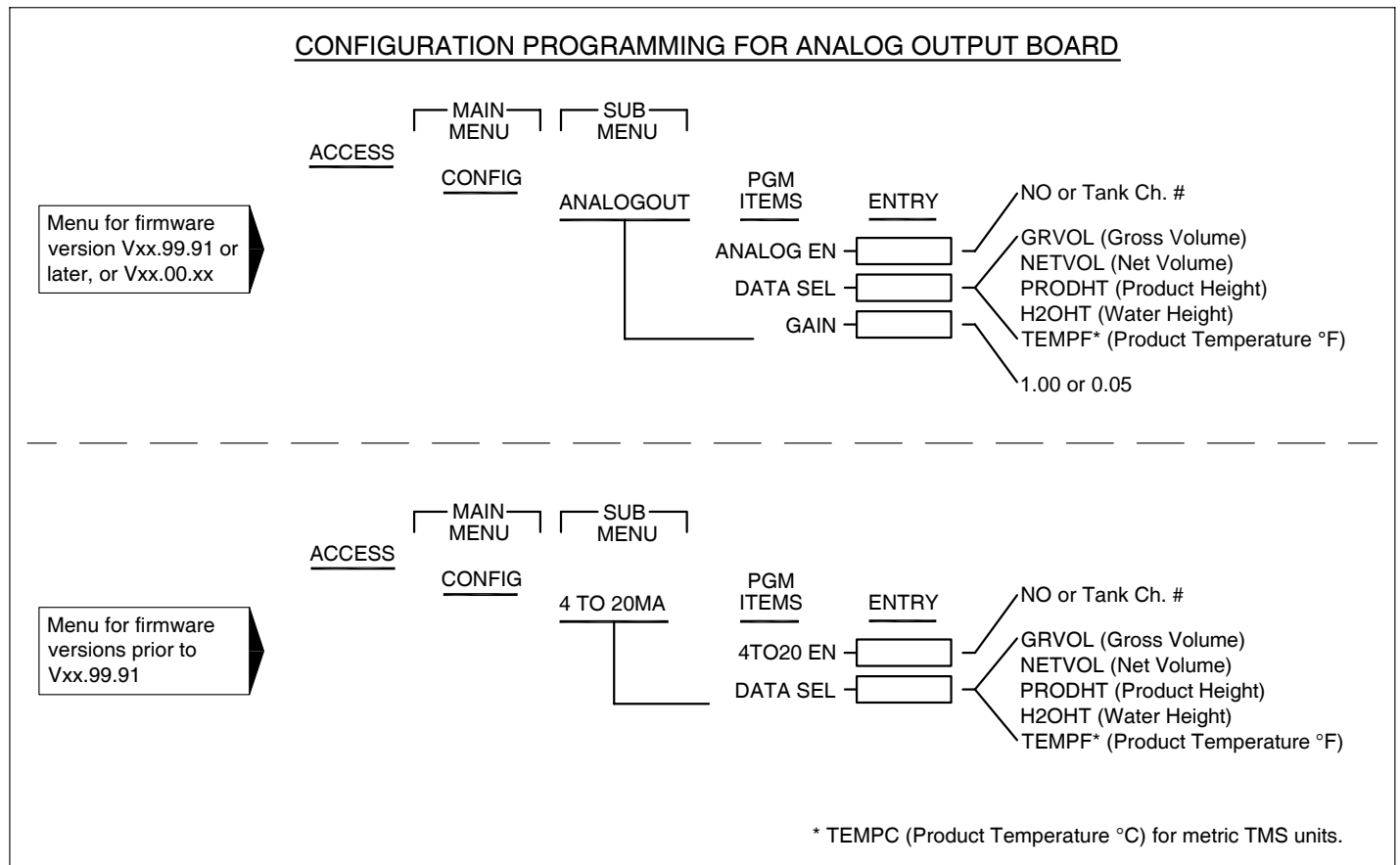

FIGURE 2

Referring to figure 1, locate dip switch assembly S1 on analog output board, and set switches 3 and 4 for the desired current loop output range as shown in Table 2. Note that dip switches 1 and 2 must always be set closed for proper operation. Ensure that TMS power is off, then install card as shown in figure 2. Connections to each analog output channel are made to "+", "GND" and "SHD" push-and-load terminals with wire cables no heavier than 20 awg. Although shielded cable is not absolutely required, it is recommended for most applications for best noise immunity. The receiving end shield should be left unterminated. Suggested stranded conductor cable part numbers are Belden 8761 (shielded) and Belden 8442 (non-shielded), or equivalents. Note: Stranded conductors should be tinned to provide reliable connections and easy insertion into terminal blocks.

After all wiring is complete, TMS power may be turned on. Observe the two LEDs designated "RUN" and "UPDATE" on the analog output board after power up. Within ten seconds these indicators should begin flashing. The "RUN" LED indicates that the analog board processor is running properly. The "UPDATE" LED indicates that the analog board is communicating with the TMS processor and is receiving new data. The update rate is approximately once per second. Board updating ceases while the user is in the ACCESS menu mode.

**PROGRAMMING:** Programming each analog output channel is simple and requires only two or three entries. The first selects which tank the data is to be taken from, and the second selects which data to use, gross volume, net volume, product level, water level or product temperature. Programming may be accomplished using the TMS front panel while in the ACCESS CONFIGURATION menu, or via any of the TMSCOMM-supported communications methods.



**OUTPUT DESCRIPTION:** (Continues on page 5)

Data Modes:

Data is scaled as follows:

4-20ma Mode

- Gross Volume:  $I = ((\text{Gross Vol}/\text{Tank Capacity}) \times 16\text{ma}) + 4\text{ma}$
- Net Volume:  $I = ((\text{Net Vol}/\text{Tank Capacity}) \times 16\text{ma}) + 4\text{ma}$
- Product Level:  $I = ((\text{Product Level}/\text{Tank Dia}) \times 16\text{ma}) + 4\text{ma}$
- Water Level:  $I = ((\text{Water Level}/\text{Tank Dia}) \times 16\text{ma}) + 4\text{ma}$
- Product Temp(°F\*):  $I = (((\text{Product Temp} + 100)/400) \times 16\text{ma}) + 4\text{ma}$

0-20ma Mode

- Gross Volume:  $I = (\text{Gross Vol}/\text{Tank Capacity}) \times 20\text{ma}$
- Net Volume:  $I = (\text{Net Vol}/\text{Tank Capacity}) \times 20\text{ma}$
- Product Level:  $I = (\text{Product Level}/\text{Tank Dia}) \times 20\text{ma}$
- Water Level:  $I = (\text{Water Level}/\text{Tank Dia}) \times 20\text{ma}$
- Product Temp(°F\*):  $I = ((\text{Product Temp} + 100)/400) \times 20\text{ma}$

where I = analog loop current in milliamperes

\* °C for metric TMS units - TMS firmware must be Vxx.99.95 or later

## OUTPUT DESCRIPTION CONTINUES:

Data Modes:

Data is scaled as follows:

### 0-24ma Mode

Gross Volume:  $I = (\text{Gross Vol/Tank Capacity}) \times 24\text{ma}$   
Net Volume:  $I = (\text{Net Vol/Tank Capacity}) \times 24\text{ma}$   
Product Level:  $I = (\text{Product Level/Tank Dia}) \times 24\text{ma}$   
Water Level:  $I = (\text{Water Level/Tank Dia}) \times 24\text{ma}$   
Product Temp( $^{\circ}\text{F}^*$ ):  $I = ((\text{Product Temp} + 100)/400) \times 24\text{ma}$

### 0-1ma Mode

Gross Volume:  $I = (\text{Gross Vol/Tank Capacity}) \times 1\text{ma}$   
Net Volume:  $I = (\text{Net Vol/Tank Capacity}) \times 1\text{ma}$   
Product Level:  $I = (\text{Product Level/Tank Dia}) \times 1\text{ma}$   
Water Level:  $I = (\text{Water Level/Tank Dia}) \times 1\text{ma}$   
Product Temp( $^{\circ}\text{F}^*$ ):  $I = ((\text{Product Temp} + 100)/400) \times 1\text{ma}$

where I = analog loop current in milliamperes

\*  $^{\circ}\text{C}$  for metric TMS units - TMS firmware must be Vxx.99.95 or later

**NOTE:** For vertical or conical tank types, product or water level current loop output is scaled using tank height rather than tank diameter.

**DEFAULT OUTPUTS:** An analog output channel will fail-safe to its full scale current loop value if the associated tank probe fails, or, if the channel is not enabled.

**VOLTAGE OUTPUT MODE:** Current loop outputs can easily be converted to voltage outputs with the addition of an external resistor. This resistor should be placed at the receiving end, across the signal input and ground terminals. See figure 3 below.

Refer to the following table for common voltage ranges and associated resistor values.

Voltage Range	R (ohms)	Mode
1-5V	249	4-20MA
0-5V	249	0-20MA
0-10V	499	0-20MA
0-6V	249	0-24MA
0-12V	499	0-24MA

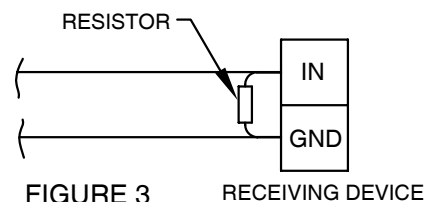

Resistor should be rated at 1/2W or higher. Suggested resistor part type is Dale CMF-65 or 70 series, or equivalent. If a resistor value other than those shown above is desired, its value must not exceed 800 ohms in order to maintain output loop compliance.