

## 2" Riser Mounting Kit for MP45xS/MP55xS Magnetostrictive Tank Gauging Probes

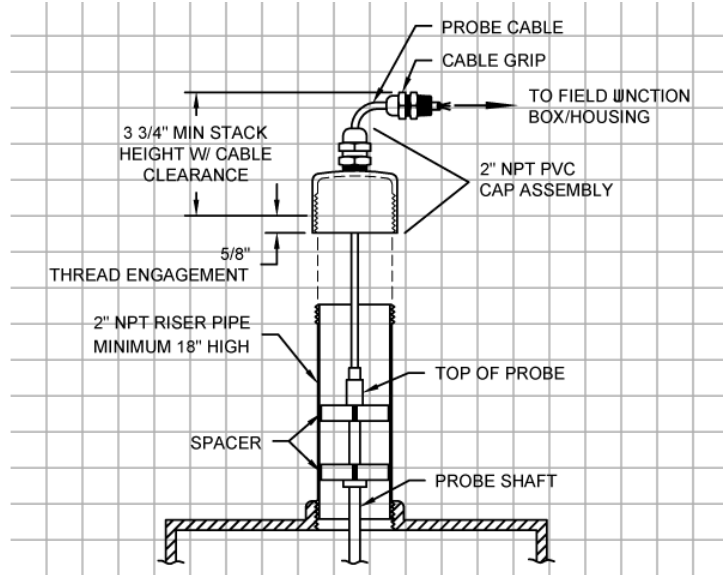
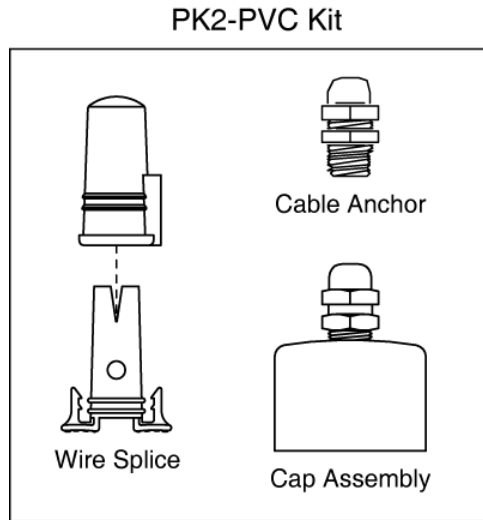

### Product Description

The PK2-PVC Riser Mount Probe Kit provides a “soft-mount” method of installation by allowing the probe to rest on the tank bottom and be stabilized within the tank riser without attachment. This method may be used for MP45xS/MP55xS series probe lengths up to 15 feet, providing easy installation and servicing by simply removing cap and lowering or raising probe by its cable. The standard kit includes a 2" PVC cap assembly with integral cable compression fitting, cable compression fitting for field junction box and wire splice kit.

**IMPORTANT:** Use PK2-DM Direct Mount Kit for probe lengths exceeding 15 feet. The riser mount should **not** be used in chemical or high heat applications without consulting factory.

### Applications

- Vertical Storage Tanks up to 15 Feet
- Underground Storage Tanks
- Sub-Base Tanks

### Specifications

- Materials: Cap: PVC  
Cable Compression Fitting: Nylon Body, TPE Rings
- Mount: 2" NPT riser pipe, minimum 18" height.
- Operating Pressure: 70 PSIG

### Model Numbers

- PK2-PVC Schedule 80 PVC Cap, Nylon Cable Compression Fitting, TPE Rings

Note: Specifications subject to change without notice. 07-06-2009