

2" Direct Mounting Kit for MP45xS/MP55xS Magnetostrictive Tank Gauging Probes

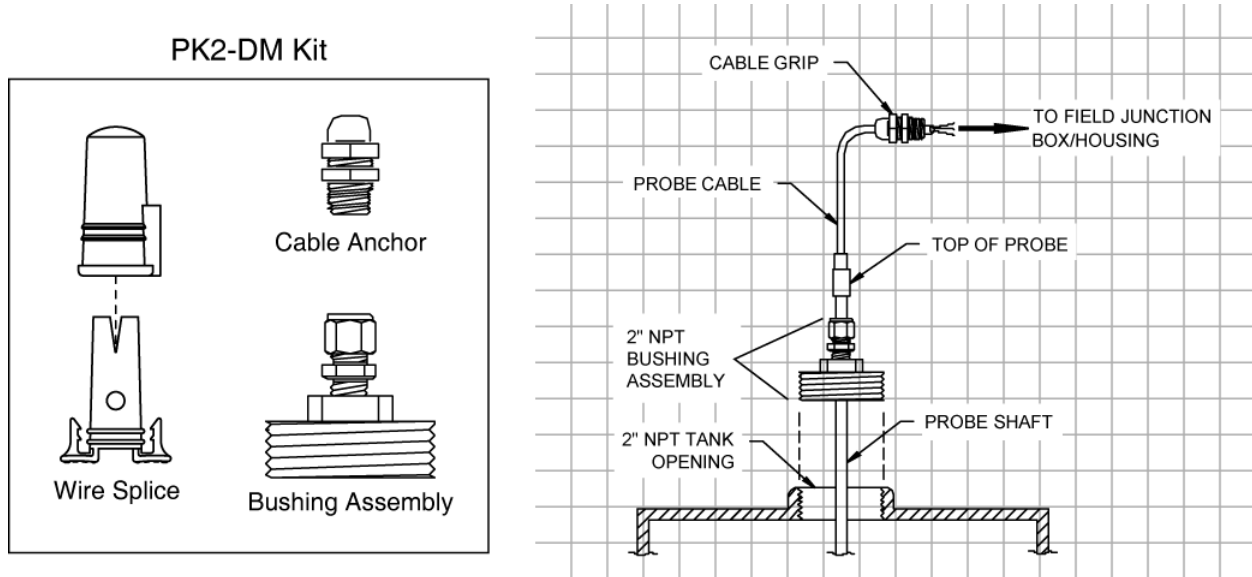

Product Description

The PK2-DM Direct Mount Probe Kit provides a means for direct or “hard” mounting an MP45xS/MP55xS series tank gauging probe. This direct mount method must be used in applications where the MP45xS/MP55xS series probe length exceeds 15 feet, but may also be required in chemical or high heat applications where isolation of the probe cable and connector from tank vapors is required. The standard kit includes a 2” NPT bushing assembly with integral probe shaft compression fitting, cable compression fitting for field junction box and epoxy seal kit. The standard kit uses Teflon compression rings to secure the probe shaft, allowing for easy re-adjustment of probe height. 316SS compression rings are also available for pressurized applications. The PK2-DM may be used in larger tank openings with the addition of a user-supplied 2” NPT bushing reducer.

Applications

- Vertical Storage Tanks > 15 Feet
- Chemical Tanks
- Heated #6 Oil Storage Tanks
- Pressurized Tanks

Specifications

- Materials: Bushing: Cast Iron or 316SS
Compression Fitting: 316SS Body, 316SS or Teflon Rings
- Mount: Minimum 2” NPT opening. Larger openings with bushing reducer.
- Stacking Height: 3” Nominal
- Operating Pressure: 316SS Compression Rings: 125 PSIG Cast Iron, 150 PSIG 316SS*
Teflon Compression Rings: 10 PSIG

* Rating is limited by probe shaft, not 316SS bushing

Model Numbers

- PK2-DM1(or DM) Cast Iron Bushing, Teflon Compression Rings (Stock, Standard)
- PK2-DM2 Cast Iron Bushing, 316SS Compression Rings (Stock)
- PK2-DM3 316SS Bushing, 316SS Compression Rings (Special Order)

Note: Specifications subject to change without notice. 07-06-2009