

Electric Analog Tank Gauge E-14

PNEUMERCATOR
Liquid Level Control Systems

120 Finn Court, Farmingdale, NY. 11735
(631)293-8450 Fax (631)293-8533 www.pneumercator.com

The Electronic Analog System uses a unique electrical mechanical design. The indicator consists of a precision motor with a built-in simulator for testing its operations and the calibration of any level warnings or control functions. This combination provides an accurate, reliable device that responds to any sensor providing a resistance output change. The slightest change in the position of the float in the liquid surface is instantaneously transmitted to the pointer of the remote indicator. The dial is to be in gallons (liters, feet, and inches, etc.). The system shall be suitable for operation with 115 volt, 60 cycles.

The system will have a tank transmitter, either Direct Lift Magnetic Float type, model 2-412, containing a float with an embedded magnet that provides a continuous uninterrupted electric signal to the remote indicator (2-412 transmitter shall mount in a standard 4" N. PT. tank opening), or a Leverage Float and Arm type, model 2-501, which utilizes the positive action of a leverage float and arm arrangement (2-501 transmitter shall mount in a standard 2" N.P.T. tank opening). The level transmitters are float actuated and are not affected by the specific gravity of the tank liquid. The accuracy of the indicator is plus or minus 1.5 percent of full scale indication.

The model E-14 has a scale length over 14 inches and include two dry contact relays for external controls. It is recommended for use on tanks up to 10,000 gallon capacity. The hinged case cover permits easy access.

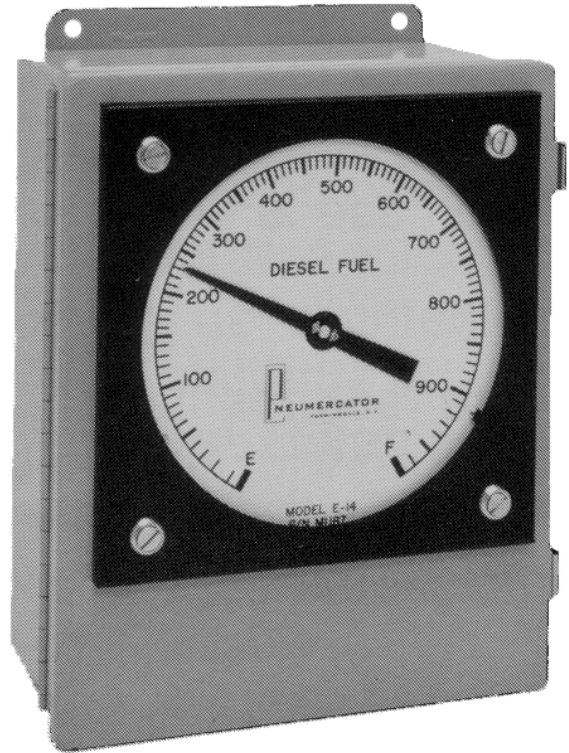

Features:

- Analog Indicator in gallons
- 14 inch Scale Length
- Indicator located up to 5000 ft. from transmitter
- Used with Pneumercator's 2-412 or 2-501 transmitters
- Built-in Tank Simulator
- NEMA 12 Enclosure
- Intrinsically Safe System
- Industrial coating (inside and out)
- Two dry contact relays

SPECIFICATIONS:

Power

115 VAC \pm 10% 60Hz, 80 watts

Accuracy

1.5% of full scale

Analog Display

Gallons (liters, feet, etc.)

Calibration

Factory calibrated with empty and full adjustments

Console Enclosure

NEMA 12 (Optional NEMA 4)

Dry Contact Relays

2 SPDT Dry relay contacts rated 5 amps at 120 VAC. (Optional 2 additional)

Intrinsic Safety

Class 1, Div. 1, Groups A, B, C, D - 12 VDC @ 31 mA

Level Sensors Input

Model 2-412 Standard for most liquids. Rated to 50 PSI and 180°F Model 2-501 for thick, viscous, liquids. Rated to 15 PSI and 180°F. Maximum height to 12 feet.

Analog Output

Optional 4-20 mA

INDICATOR DETAIL

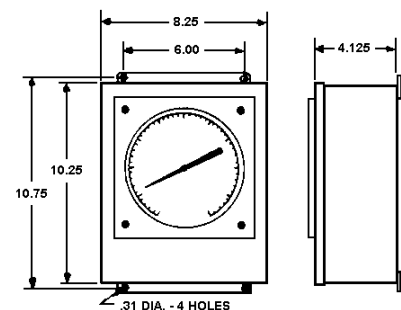

MEMBER
PEI
Process Equipment Inc.